

UNCLASSIFIED

NAVAL AIR WARFARE CENTER AIRCRAFT DIVISION
PATUXENT RIVER, MARYLAND



TECHNICAL REPORT

REPORT NO: NAWCADPAX/TR-2002/71

REVIEW OF THE CARRIER APPROACH CRITERIA FOR CARRIER-BASED AIRCRAFT PHASE I; FINAL REPORT

by

**Thomas Rudowsky
Marshall Hynes
Melvin Luter
CAPT Robert Niewoehner
Page Senn
Henry Beaufreere
Albert Sonntag**

**Stephen Cook
Robert Heffley
Thomas Lawrence
Douglas Bollman
Dr. Wayne Durham
Michael Yokell**

Approved for public release; distribution is unlimited.

UNCLASSIFIED

DEPARTMENT OF THE NAVY
NAVAL AIR WARFARE CENTER AIRCRAFT DIVISION
PATUXENT RIVER, MARYLAND

NAWCADPAX/TR-2002/71

REVIEW OF THE CARRIER APPROACH CRITERIA FOR CARRIER-BASED AIRCRAFT -
PHASE I; FINAL REPORT

by

Thomas Rudowsky
Marshall Hynes
Melvin Luter
CAPT Robert Niewoehner
Page Senn
Henry Beaufreere
Albert Sonntag

Stephen Cook
Robert Heffley
Thomas Lawrence
Douglas Bollman
Dr. Wayne Durham
Michael Yokell

RELEASED BY:

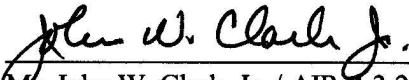
 10-10-02

Mr. John W. Clark, Jr. / AIR-4.3.2 / DATE
Head, Aeromechanics Division
Air Vehicle Department
Naval Air Systems Command

REPORT DOCUMENTATION PAGE			Form Approved OMB No. 0704-0188	
Public reporting burden for this collection of information is estimated to average 1 hour per response, including the time for reviewing instructions, searching existing data sources, gathering and maintaining the data needed, and completing and reviewing this collection of information. Send comments regarding this burden estimate or any other aspect of this collection of information, including suggestions for reducing this burden, to Department of Defense, Washington Headquarters Services, Directorate for Information Operations and Reports (0704-0188), 1215 Jefferson Davis Highway, Suite 1204, Arlington, VA 22202-4302. Respondents should be aware that notwithstanding any other provision of law, no person shall be subject to any penalty for failing to comply with a collection of information if it does not display a currently valid OMB control number. PLEASE DO NOT RETURN YOUR FORM TO THE ABOVE ADDRESS.				
1. REPORT DATE		2. REPORT TYPE		3. DATES COVERED
		Technical Report		November 1999 – October 2001
4. TITLE AND SUBTITLE			5a. CONTRACT NUMBER	
Review of the Carrier Approach Criteria used in the Prediction of Approach Speed for Carrier-Based Aircraft - Phase I; Final Report			5b. GRANT NUMBER	
			5c. PROGRAM ELEMENT NUMBER	
6. AUTHOR(S)			5d. PROJECT NUMBER	
Thomas Rudowsky, Stephen Cook, Marshall Hynes, Robert Heffley Melvin Luter, Thomas Lawrence, CAPT Robert Niewoehner, Douglas Bollman, Carroll Senn, Dr. Wayne Durham, Henry Beaufriere, Albert Sonntag Michael Yokell			5e. TASK NUMBER	
			5f. WORK UNIT NUMBER	
7. PERFORMING ORGANIZATION NAME(S) AND ADDRESS(ES)			8. PERFORMING ORGANIZATION REPORT NUMBER	
Naval Air Systems Command 48110 Shaw Road, Unit 5, Suite 1320B Patuxent River, Maryland 20670-1906			NAWCADPAX/TR-2002/71	
9. SPONSORING/MONITORING AGENCY NAME(S) AND ADDRESS(ES)			10. SPONSOR/MONITOR'S ACRONYM(S)	
Naval Air Systems Command 48110 Shaw Road, Unit 5, Suite 1320B Patuxent River, Maryland 20670-1906			NAVAIRSYSCOM, PEO(JSF)	
			11. SPONSOR/MONITOR'S REPORT NUMBER(S)	
12. DISTRIBUTION/AVAILABILITY STATEMENT				
Approved for public release; distribution is unlimited.				
13. SUPPLEMENTARY NOTES				
14. ABSTRACT				
The approach speed criteria used in the design and development of carrier-based aircraft was investigated. This report provides a historical review, analysis of requirements, and an analysis of legacy aircraft relative to the approach speed criteria. The relevancy and adequacy of the carrier approach speed criteria are assessed. Recommendations for future investigations and assessment are presented.				
15. SUBJECT TERMS				
Carrier Approach Speed, Design Criteria				
16. SECURITY CLASSIFICATION OF:			17. LIMITATION OF ABSTRACT	18. NUMBER OF PAGES
a. REPORT	b. ABSTRACT	c. THIS PAGE		19a. NAME OF RESPONSIBLE PERSON
Unclassified	Unclassified	Unclassified	SAR	Tom Rudowsky
				19b. TELEPHONE NUMBER (include area code)
				301-342-8526

THIS PAGE INTENTIONALLY LEFT BLANK

SUMMARY

The Joint Strike Fighter (JSF) Program Office sponsored a study to review the existing Carrier Approach Criteria (CAC). These criteria are also commonly referred to as the Approach Speed Criteria or Vpa Criteria. The study's motivation was based on questions surrounding the applicability of the CAC, which have evolved over the past 30+ years, as design tools for the prediction of approach speed. With significant technological advancements during this period, it was questioned if the criteria's assumptions and application were still valid for design purposes. It is clear that these criteria considerably affect the design space of Naval carrier-based aircraft and reduce the flexibility of the designer for satisfying other mission critical requirements. For these reasons, it is imperative that the Navy have a full understanding of the design impact of these criteria and can clearly justify their application in predicting Vpa.

The Joint Service Specification Guide (JSSG) criteria definitions were used as the basis of this study. The CAC include the glide slope transfer (popup) maneuver, small and large throttle response, field of view (FOV), Level 1 flying qualities (FQ) (primarily roll control and flightpath stability), stall margin, and flight control limit speed. Waveoff and bolter performance were also considerations in the Vpa definition and are included as part of the CAC.

The results documented in this report represent the first of several planned phases. The focus of this phase was to research and analyze the assumptions behind the JSSG criteria. It is recognized that a variation of the JSSG definitions was used for the JSF Joint Model Specification and those variations are discussed. It was the intent of this phase to identify shortcomings with the existing criteria, conduct analysis and research for criteria development for low risk, high payoff areas that were clearly seen as inadequate, and identify areas for future research and assessment. It was not the intent to emerge from this phase with a new set of criteria. However, with the background information provided, the designer and the acquisition community are in a better position to make informed program decisions relative to the criticality of the individual criteria. It is intended that further investigation will yield new and/or improved criteria.

The study developed formal definitions to rate the adequacy and relevancy of each of the criteria. In general, the criteria were found to lack traceability to the approach task. Based on these definitions, the FOV criterion was found to be adequate. The stall speed margin, GS transfer (popup) maneuver, and small throttle response were rated as inadequate. The remaining criteria were rated as marginally adequate.

Significant conclusions from this phase of the investigation are:

- a) Many of the existing criteria are not well-founded. The majority of the criteria are based on empirical data from aircraft designs that are in some cases 40 years old.
- b) Current application of the CAC (to define Vpa) is not consistent with the intent of early pioneers of CAC development.

- c) Analysis of Naval Safety Center data from January 1980 through May 2001 concluded that there is no longer a credible correlation between mishap rate and Vpa within the scope of aircraft reviewed and therefore should not be used as an indicator of safety.
- d) Because Naval aircraft programs almost always involve competition between two or more design concepts, it becomes extremely difficult from an industry perspective to fail to satisfy any of the CAC to meet the Vpa requirement prior to System Development and Demonstration (SDD). Therefore, the criteria, although not specifically defined as requirements, in practice become “hard requirements” to the designer.
- e) The practice of separately defining a limit Vpa, arresting gear limit speed, and the wind over deck limit overspecifies the problem, which leads to incompatible requirements.

The key recommendations from this phase of the investigation are:

- a) A Phase II investigation should be conducted to develop criteria that are traceable to the approach task.
- b) NAVAIRSYSCOM should define a process for periodic review and assessment of the CAC that includes both government and industry representatives.
- c) Further analysis of Key Performance Parameter (KPP) selection should be conducted in a Phase II study. Further discussion between the program manager, requirements community, and engineering should address KPP selection if it is desired that a KPP is warranted for the approach task.

Contents

	<u>Page No.</u>
Summary.....	iii
List of Figures	xiii
List of Tables	xv
Acknowledgements.....	xvii
Introduction.....	1
Background	1
Purpose.....	3
Scope.....	3
Organization of Report.....	3
Methods.....	3
General.....	3
Historical Review.....	4
Current Criteria Review	4
Review of Safety Implications	4
Approach Environment Decomposition	5
Simulation.....	5
Trade Studies.....	6
Chronology.....	6
Historical Review.....	7
Introduction.....	7
Flat-Paddles Approach Technique	7
Propeller-to-Jet Aircraft Transition.....	9
Royal Navy Influences.....	10
Development of Approach Speed Prediction.....	12
McDonnell Aircraft Corporation Study (1953)	12
National Advisory Committee for Aeronautics Approach Speed Study	15
Stall Margin Criteria Evolution	17
U.S. Navy Contributions 1959 – 1968	18
Research Efforts	18
Navy A-7 Experience.....	22
Navy A-6 Experience.....	22
“Backside” Technique	23
Approach Speed Criteria Evolution.....	24
Glide Slope Transfer (Popup) Maneuver.....	24
Field of View	25

	<u>Page No.</u>
Level I Flying Qualities	26
General Flying Qualities	26
Roll Control	26
Flightpath Stability.....	27
Stall Speed Margin.....	27
Flight Control Limit Speed	27
Thrust Response	28
Large Throttle Response (Longitudinal Acceleration)	29
Small Throttle Response	30
Waveoff.....	30
Bolter.....	31
Summary.....	33
Requirements	35
General.....	35
Roles and Responsibilities	35
Government Roles.....	35
Requirements Generation.....	35
Risk Management	37
Industry Roles	38
Value	38
Design Process	39
Carrier Approach Criteria Inconsistencies	41
Naval Aircraft Design Challenge	43
General.....	43
Aircraft Carrier Environment.....	43
Flight Deck Configuration.....	43
Arresting Gear Systems	43
General Description	43
Performance Capabilities	44
Aircraft Recovery Bulletins	45
Fresnel Lens Optical Landing System	46
General Description	46
Stabilization	48
Improved Fresnel Lens Optical Landing System.....	48
Drop Lights	48
Automatic Carrier Landing System	49
Approach and Landing Patterns	50
The Carrier Landing.....	50
Key Aircraft Characteristics.....	53
General.....	53
Wing Design	53

	<u>Page No.</u>
High Lift Systems	54
Variable Wing Incidence	54
Variable Wing Sweep	54
Boundary Layer Control	54
Approach Angle of Attack	54
Aircraft Approach Gross Weight	54
Thrust Incidence.....	55
Speed Brakes.....	55
Direct Lift Control	55
Fly-by-Wire/Light Flight Controls	56
Materials	57
Pilot Perspective.....	57
Sensory Information.....	58
Day/Night Distinctions	60
Glide Slope Technique.....	62
Autothrottle Issues	63
Traditional Autothrottles.....	63
Alternate Control Paradigms.....	64
Lineup	65
Waveoff.....	65
Direct Lift Control	65
Engine Inoperative (for Multi-Engine Aircraft).....	66
Landing Signal Officer Perspective	66
Responsibilities	66
Landing Signal Officer Survey.....	67
Safety Implications	67
General.....	67
Analysis.....	68
Carrier Approach Criteria	75
General.....	75
Glide Slope Transfer (Popup) Maneuver.....	75
Definition.....	75
Methodology	75
Simulation.....	76
Flight Test Validation	76
Legacy Aircraft Capability.....	77
Field of View	78
Definition.....	78
Methodology	78
Simulation.....	78
Flight Test Validation.....	79
Legacy Aircraft Capability.....	79

	<u>Page No.</u>
Flying Qualities.....	80
General.....	80
Roll Control.....	81
Definition.....	81
Methodology.....	81
Legacy Aircraft Capability.....	82
Flightpath Stability.....	83
Definition.....	83
Methodology.....	84
Legacy Aircraft Capability.....	84
Stall Speed Margin.....	85
Definition.....	85
Methodology.....	85
Piloted Simulation.....	85
Flight Test Validation.....	85
Legacy Aircraft Capability.....	85
Flight Control Limit Speed.....	86
Definition.....	86
Methodology.....	86
Piloted Simulation.....	87
Flight Test Validation.....	87
Legacy Aircraft.....	87
Longitudinal Acceleration (Large Throttle Response).....	87
Definition.....	87
Methodology.....	88
Piloted Simulation.....	88
Flight Test Validation.....	88
Legacy Aircraft Capability.....	88
Small Throttle Response.....	89
Definition.....	89
Methodology.....	89
Piloted Simulation.....	89
Flight Test Validation.....	89
Legacy Aircraft Capability.....	89
Waveoff.....	90
Definition.....	90
Methodology.....	90
Piloted Simulation.....	90
Flight Test Validation.....	90
Legacy Aircraft Capability.....	91
Bolter.....	94
Definition.....	94

	<u>Page No.</u>
Methodology	94
Piloted Simulation.....	95
Flight Test Validation.....	96
Legacy Aircraft Capability.....	97
Flight Test Considerations	97
Approach Angle of Attack Validation.....	97
General.....	97
Shore-Based Buildup and Shipboard Tests.....	97
Degraded Configurations	98
Shipboard Testing Considerations	99
Assessment of Carrier Approach Criteria	101
General.....	101
Glide Slope Transfer (Popup) Maneuver.....	102
Relevance	102
Adequacy	103
Investigative Effort	104
Summary.....	105
Field of View	105
Relevance	105
Adequacy	105
Investigative Effort	106
Summary.....	106
Flying Qualities.....	106
General.....	106
Relevance	106
Adequacy	107
Roll Control.....	108
Relevance	108
Adequacy	108
Investigative Effort	109
Flightpath Stability.....	109
Relevance	109
Adequacy	110
Summary.....	113
Stall Speed Margin.....	113
Relevance	113
Adequacy	113
Summary.....	114
Flight Control Limit Speed	114
Relevance	114
Adequacy	114
Summary.....	115

	<u>Page No.</u>
Longitudinal Acceleration (Large Throttle Response)	115
Relevance	115
Adequacy	115
Summary	116
Small Throttle Response	116
Relevance	116
Adequacy	116
Summary	116
Waveoff	117
Relevance	117
Adequacy	117
Summary	118
Bolter	119
Relevance	119
Adequacy	119
Summary	120
Carrier Approach Criteria Definition Alternatives	121
General	121
Application of Task-Based and Analytical Criteria	121
Further Investigation of Existing Criteria	123
General	123
Glide Slope Transfer (Popup)	124
Test Pilot School Simulation	125
Future Efforts	127
Field of View	128
Flying Qualities	128
Roll Control	129
Flightpath Stability	129
Stall Speed Margin	130
Flight Control Limit Speed	130
Longitudinal Acceleration (Large Throttle Response)	130
Small Throttle Response	131
WaveOff	131
Bolter	131
Other Assessment Areas	132
Operator Concepts	132
Unmanned Aerial Vehicle Implications	132
Requirements Definition Alternative	133
General	133
Requirements	133
Speed Definitions	133

	<u>Page No.</u>
Approach Speed	133
Value and Design Benefits.....	134
Requirements and Risk Benefits.....	136
Impact on Carrier Approach Criteria	136
Summary.....	136
Conclusions and Recommendations	139
General.....	139
Conclusions	139
Recommendations	140
Specific	141
Glide Slope Transfer (Popup) Maneuver.....	141
Conclusions	141
Recommendations	141
Field of View	141
Conclusions	141
Recommendations	142
Flying Qualities.....	142
General.....	142
Roll Control.....	142
Flightpath Stability.....	143
Stall Speed Margin.....	143
Conclusions	143
Recommendations	144
Flight Control Limit Speed	144
Conclusions	144
Recommendations	144
Large Throttle Response (Longitudinal Acceleration)	144
Conclusions	144
Recommendations	144
Small Throttle Response	145
Conclusions	145
Recommendations	145
Waveoff.....	145
Conclusions	145
Recommendations	145
Bolter Maneuver	146
Conclusions	146
Recommendations	146
References	147
Glossary	155

Appendices

A. Carrier Approach Criteria Study Team Members.....	159
B. Joint Service Specification Guide Ground Rules for the Carrier Approach.....	161
Criteria	
C. Short-Term Flightpath Response Criteria Investigative Effort.....	165
D. Field of View Investigative Effort	181
E. Chronology of Carrier-Based Aircraft	195
Distribution	199

List of Figures

<u>Figure No.</u>	<u>Title</u>	<u>Page No.</u>
1	Carrier Landing Pattern for Propeller Aircraft (circa World War II)	8
2	FJ-1 Fury (Left) and FH-1 Phantom (Right).....	9
3	F4U-5N Corsair (Left) and F2H-1 Banshee (Right).....	10
4	Straight Deck and Angled Deck Comparison View	11
5	USS FRANKLIN D. ROOSEVELT from an A-6A on Approach	12
6	XF-88A Voodoo	13
7	Illustration of Three Regions of the Thrust Required Curve	20
8	F8U Crusader and F4D-1 Skyray	23
9	Requirements Process	37
10	Carrier Suitability Design Constraints	40
11	Design Space.....	41
12	MK 7 Mode 3 Arresting Gear Performance.....	45
13	Fresnel Lens Optical Landing System	47
14	Drop Light and Flight Deck Lighting Indications	49
15	Direct Lift Control	56
16	Landing Signal Officer Survey Results	67
17	Vpa versus Aircraft Mishaps per 10,000 Landings (1964).....	68
18	Mishaps Associated with the Carrier Approach Task (January 1980 – May 2001)	70
19	Mishaps versus Approach Speed (January 1980 – May 2001).....	71
20	Mishaps per 10,000 Carrier Landings versus Approach Speed..... (January 1980 – May 2001)	72
21	Carrier Approach Mishap Data Comparison (1964 versus 2001)	73
22	Historical Comparison of Mishap Rate and Key Milestones.....	74
23	Glide Slope Transfer Maneuver	76
24	Field of View Geometry	78
25	Flightpath Stability.....	83
26	Flightpath Stability Characteristics of Selected Legacy Aircraft	84
27	Small Throttle Transient Criterion.....	89
28	Hook Altitude Loss during Waveoff versus Sink Speed of Legacy Aircraft	92
29	Profile of the Carrier Approach Task.....	104
30	F4D-1 Flightpath Stability Analysis Results	112
31	Criterion Traceability.....	123
32	Profile of the Carrier Approach Task.....	125
33	Speed Relationships	133
34	Disadvantage of an Explicit Vpa Requirement.....	135
35	Alternative Approach Design Benefit.....	135
36	Controlling Risk and Growth through Wind Over Deck Selection.....	136

THIS PAGE INTENTIONALLY LEFT BLANK

List of Tables

<u>Table No.</u>	<u>Title</u>	<u>Page No.</u>
1	Key Finding from XF-88A Flight Testing.....	13
2	Eight Prediction Methods for Vpa from NACA Report	16
3	Arresting Systems Characteristics	44
4	FLOLS Field of View	47
5	Summary of Mishaps Associated with the CV Approach Phase	70
6	Glide Slope Transfer (Popup) Performance of Legacy Aircraft (Analytical).....	77
7	Field of View of Legacy Aircraft from Analysis	80
8	Simulated Roll Performance for Several Fleet Aircraft.....	82
9	Stall Speed Margin of Selected Legacy Aircraft (Analytical)	86
10	Large Throttle Acceleration (Historical)	88
11	Waveoff Performance of Legacy Aircraft (Analysis).....	91
12	Waveoff Performance of Legacy Aircraft (Historical)	91
13	Flight Test Waveoff Performance Results (Historical)	93
14	Flight Deck Remaining from the Last CDP to Angled Deck Round-Down.....	95
15	Criterion Relevancy Definitions	101
16	Criterion Adequacy Definitions	101
17	Carrier Approach Criteria Relevancy and Adequacy Ratings	102
18	Flightpath Stability Characteristics of Four F-4 Variants	111

THIS PAGE INTENTIONALLY LEFT BLANK

ACKNOWLEDGEMENTS

This report would have not been possible without the support and resources provided by the Joint Strike Fighter (JSF) Program Office. In particular, the authors are grateful for the efforts and leadership of Mrs. Lisa Nyalko of the Air Vehicle Analysis and Integration Integrated Product Team. The authors would also like to thank the JSF Leadership for supporting this important subject to carrier-based Naval aviation.

Additionally, the study required extensive discussions with retired aircrew and engineers who developed the criteria used to predict carrier approach speed, and waveoff and bolter performance. The authors would like to particularly recognize Messrs. Jack Linden, Bill Koven, and Hal Andrews. These individuals gave freely of their time and provided vital insights and perspective that were not otherwise available.

The research, investigations, and data to support the findings of this report would not have been as comprehensive without the direct support and involvement of Industry representatives. In particular, the efforts of Boeing and Lockheed Martin have been indispensable to provide the Industry view and perspective related to the carrier approach criteria.

This study also used several facilities in the generation and assessment of the carrier approach task. The authors greatly appreciate the test pilot support of the experiments from CAPT(s) Robert Niewoehner, LCDR Chris McCarthy, LCDR Jack Waters, LT Matthew Paradise, and Dr. Wayne "Bull" Durham. The authors would like to thank the United States Naval Test Pilot School and, in particular, Messrs. Robert Miller and Joe King for contributing their time and simulation facility for the conducting flightpath control parametric investigation. Additionally, the authors are grateful to the Virginia Polytechnic University and in particular Dr. Wayne "Bull" Durham for the use of the Flight Research Simulator in support of the field-of-view investigation. Messrs. Bill Oetjens, Henrik Pettersson, and Roger Beck of Virginia Polytechnic University are recognized for their support of this experiment.

Finally, the authors would like to recognize the significant contributions of all the team members identified in Appendix A. It is recognized that many team members reprioritized their workload and sacrificed their time in order to contribute to this study. The authors are indebted to all the team members for their dedication and commitment to this study.

THIS PAGE INTENTIONALLY LEFT BLANK

CHAPTER 1: INTRODUCTION

1.1 BACKGROUND

Naval aviation has many unique characteristics that separate itself from other forms of aircraft operation and deployment. Most notable is the requirement for aircraft to launch and recover aboard the aircraft carrier (CV). Since World War II, Naval aviation has served as a key element in our national defense force structure. Over this period, Naval aviation has successfully met the demands of changing Naval mission requirements. This challenge has shaped the capabilities of both the aircraft and the CV's while maintaining the basic requirement for safe and efficient CV launch and recovery. Changing requirements have been met through innovation and a careful infusion of technology to both the CV and the aircraft. Aircraft have been driven to design features that tailor it to the unique aspects of the CV, and similarly CV design has been driven to adapt itself to the unique aspects of the aircraft. Together, they have continued to provide overwhelming capability and flexibility to our national leadership.

In many cases, carrier-based aircraft have demonstrated capability equal to land-based aircraft, providing nearly a seamless option to the Warfighters. The design considerations of carrier-based aircraft are many. When designing for the CV approach and recovery task, careful consideration must be given to both the limitations of the CV and the aircraft. Some of the key CV design considerations include constrained landing area, arresting gear performance, wind over deck (WOD) limitations, and the Optical Landing System (OLS). Aircraft design considerations historically considered key to safe and efficient recovery include approach speed (V_{pa}), field of view (FOV), aircraft FQ, and propulsion system performance and response. Therefore, aircraft configuration (geometry and weight), flight control system design, and engine selection all play a vital role to ensure safe and efficient recovery.

In the acquisition of military aircraft, governmental program management requires a consistent method for assessing the progress and identification of risk of the design and/or concept. To address the inherent risks associated with an aircraft's ability to safely and efficiently recover aboard the CV, the Naval Air Systems Command (NAVAIRSYSCOM) has adopted a series of design criteria known as the Carrier Approach Criteria (CAC). (For the purposes of this report the CAC include only those criteria associated with the prediction of V_{pa} including bolter and waveoff performance.) The CAC are currently defined in the Joint Service Specification Guide (JSSG), reference 1. Excerpts are presented in Appendix B. Based on decades of U. S. Navy (USN) experience, governmental program management and the NAVAIRSYSCOM engineering community have used the CAC to independently identify and assess risk associated with the CV recovery phase.

The CAC also provide the aircraft designer with metrics through which the aircraft can be assessed early in the design phase to determine its ability to meet the CV approach and recovery task. It should be understood that these criteria are not the only considerations the designer must address in the design evolution. Additional mission requirements such as aircraft range/radius, combat maneuvering, payload, launch WOD, and other operational requirements are required to be balanced with the CAC. The CAC were first developed in the early 1950's and have evolved

to those presented in reference 1. Their definitions have been adapted to the Joint Strike Fighter (JSF) program for use in the JSF Joint Model Specification (JMS), reference 2.

The reference 1 definitions of the CAC provide guidance to the accepted definition of V_{pa}, bolter, and waveoff performance. The JSSG provides the framework and definitions under a joint service document to aid in the development of program specifications. Since the JSSG is a tool providing guidance, program adoption of the JSSG for the purpose of specification development may and do vary with the concurrence of the governmental program management and procuring agency. This is the case with the JSF JMS, reference 2, relative to the CAC. The JMS definitions of V_{pa}, bolter, and waveoff performance are not completely representative of reference 1. The focus of this study was not to assess the JMS modified definitions but to address the JSSG definitions. For the purposes of clarity within this report, where differences between the JSSG and JMS are considered relevant, the differences are presented and implications discussed. Any alteration of the JSSG CAC definitions or findings of this report could be considered by the JSF Program Office (JSFPO) for potential modification of the JMS. However, no direct recommendations to the JSF program relative to the JMS are presented.

The JSF program is using common manufacturing concepts and designs to achieve an affordable, multiservice, next generation strike-fighter weapon system while improving lethality, survivability, and supportability. There are three variants that comprise the JSF concept: the Conventional Takeoff and Landing variant for the U. S. Air Force (USAF), the Short Takeoff and Vertical Landing (STOVL) variant for the U. S. Marine Corps (USMC) and United Kingdom (UK), and the Carrier Variant (CV) variant for the USN. Due to its unique multivariant design requirements and associated weight restrictions, the design process of the JSF has raised questions on the use and applicability of the CAC. Specifically, the relevancy and adequacy of the criteria has been questioned in light of available aircraft design options. These options could include full digital fly-by-wire/light aircraft control systems that incorporate a fully integrated propulsion control system; these technologies could be tailored to improve the CV approach and recovery task.

To assess whether these criteria remain relevant and adequate in light of technological innovation and maturity, a study was sponsored by the JSFPO and NAVAIRSYSCOM. The study's goal was to identify areas where the CAC could be modified in an effort to increase the design space for the designer while not imposing additional risk to governmental program management or procuring agency. Responding to this request, NAVAIRSYSCOM initiated a joint study bringing together all appropriate NAVAIRSYSCOM engineering disciplines and industry representation.

There were several tasks associated with this study. They included (a) the analysis of the reference 1 CAC, (b) documentation of the historical development of the CAC, (c) exploration of the various elements that define the CAC, (d) determination of the relevancy and adequacy of the CAC, and (e) assessment of potential aerodynamic, mechanical, propulsive, or electronic advances which might justify a change or relaxation in the CAC.

Due to the complexity of this undertaking and limited resources, the study was planned to be spread over several phases. This report represents the Phase I findings. Phase II study areas are described and provide follow-on activities that will assist in the studies completion and potential adoption of proposed changes to the CAC. A list of team members is provided in Appendix A.

1.2 PURPOSE

The purpose of this report is to present the Phase I findings of a joint industry/government study assessing the relevancy and adequacy of the CAC as defined in reference 1.

1.3 SCOPE

The scope of this study only includes those areas associated with the CAC as defined in reference 1 and presented in Appendix B. It is understood that many other design and operational factors can contribute to the safe and efficient recovery of carrier-based aircraft. Every attempt was made to identify those factors and assess their relevance to the prediction of Vpa, bolter, and waveoff performance. When considered relevant, those factors are discussed.

1.4 ORGANIZATION OF REPORT

The report is structured using a Chapter format. Following the Introduction, Chapter 2 presents the relevant history of the CAC presenting the motivation and development by the early CAC investigators. Discussion of the requirements process and the roles and responsibilities was necessary to gain an appreciation of the need and use of the CAC and is provided in Chapter 3. Chapter 4 presents the challenges posed to the designer and the user in an aircraft development program. Chapter 5 provides a review of the CAC including definitions, methodology, and when data were available, legacy aircraft capability as measured against the CAC. The report then follows in Chapter 6 with an assessment of CAC specifically addressing their relevancy and adequacy to the CV approach task. CAC Definition Alternatives are addressed in Chapter 7 followed by Requirements Definition Alternatives in Chapter 8. The Conclusions and Recommendations are provided in Chapter 9. A series of appendices are included for future reference.

1.5 METHODS

1.5.1 GENERAL

The study was organized into several review and assessment areas including research, simulation, and analysis activities. To develop an understanding of the CAC, a historical review was conducted to trace the criteria development from WWII to present. This information provided a solid foundation to assess the CAC application, key assumptions, and limitations. To make comparisons of the criteria against current operational and legacy carrier-based aircraft, a number of aircraft were evaluated against the CAC. This effort provided insight into the criteria's overall ability to predict Vpa, bolter, and waveoff performance. A review of mishap rate during the CV approach task to assess potential safety implications of Vpa was also conducted. Another activity, referred to as the CV approach environment decomposition,

evaluated and defined the attributes associated with CV approach task that a designer must address to ensure acceptable characteristics. Utilization of simulation tools and facilities allowed for the evaluation of the sensitivity of the criteria parameters to the pilot-in-the-loop CV approach task. This effort assisted in addressing potential candidates for criteria modification and provided increased understanding of the criteria's influence on the CV approach task. JSF design trade study information provided by industry was also used to aid in the assessment of the aircraft configuration sensitivity to the CAC. Together, these activities provided the necessary information and data to address the relevancy and adequacy of the CAC for use with future carrier-based aircraft acquisition programs.

1.5.2 HISTORICAL REVIEW

A literature search was conducted using USN, National Aeronautics and Space Administration (NASA), and industry reports associated with the CV approach environment. Additional information was obtained from interviews with selected authors of these reports, as well as aircrew who conducted testing that assisted in the acquisition of the supporting data. The literature search documented the historical development of the CAC. This effort outlined the purpose and reasoning that allowed for the USN to adopt and evolve the CAC for use in acquisition programs. It is from this historical review that an understanding was achieved regarding how and why the criteria were developed and adopted. This effort provided the criteria limitations and assumptions yielding a foundation for the assessment of the criteria's relevancy and adequacy. The literature search serves as a historical record of the CAC as understood by the authors of this report. Every effort was taken to develop a detailed history of this subject. However, due to the significant time period reviewed, there may exist additional relevant references that were not identified for review.

1.5.3 CURRENT CRITERIA REVIEW

The CAC were reviewed using 2 degree-of-freedom (DOF) analysis methods to determine current operational and legacy aircraft capability when data were available. These methods are the same used in government assessments. The criteria methodology were applied "as is" regardless if the aircraft were designed to the CAC or some other design metrics. These results, coupled with known operational capability of the aircraft assessed, provided a basis for comparison. This comparison provided a foundation to assess if the CAC serve as satisfactory metrics for aircraft design purposes.

1.5.4 REVIEW OF SAFETY IMPLICATIONS

A review of aircraft mishaps occurring during the CV approach phase was evaluated to determine any direct correlation of aircraft mishap rate to aircraft Vpa. The analysis used two data sets. They included data from the Naval Safety Center (NSC) from 1964, reference 3, and more recent data obtained from the NSC for the period January 1980 to May 2001, reference 4. The reference 3 data were used based on its apparent correlation of mishap rate with Vpa. The reference 4 data were obtained to provide an updated review of the reference 3 findings.

The NSC data contained in reference 4 were obtained for each aircraft model in fleet operation during the time period. Each mishap was assessed based on mishap summary information. In addition, any associated aircraft attributes that may have contributed or aggravated the conditions of the mishap were considered. The evaluation using the reference 4 data focused on those mishaps that were considered relevant to the CV approach task. Therefore, of the total mishaps obtained from the NSC, only a subset was considered relevant to the CV approach task. Correlation of Vpa and mishap rate was then evaluated and compared to the reference 3 findings and conclusions derived.

1.5.5 APPROACH ENVIRONMENT DECOMPOSITION

The CV approach environment involves a complex series of systems over a wide variety of conditions that pose significant challenges to the designer. To aid in the description of this multidimensional, multivariable environment, a systems engineering approach was applied to better define and categorize the CV approach environment by decomposing it into various elements. This process yielded a breakdown of the CV approach characteristics and aided in the determination of the interdependencies of these characteristics. The information gathered was then balanced against the CAC to identify any areas where the criteria did not address the CV approach environment. The purpose of this exercise was to ensure all relevant considerations were identified by the study.

This decomposition involved identifying Vpa-related physical and functional characteristics of the CV, the aircraft, the crew, and the interfaces between them, with an emphasis on those characteristics linked to performance and FQ. The purpose of this exercise was to thoroughly document these characteristics and examine them in an object-oriented methodology depicting the various interdependencies of this multivariable, multidimensional system. The goal of the decomposition was to account for all the factors that impact approach speed in the CV approach environment and to provide traceability of these factors and their interrelationships to the existing CAC. The results of the approach task decomposition provided added confidence that a critical review of the CAC criteria alone was sufficient to highlight any criteria deficiencies and ensure all tasks and elements of the carrier environment were properly considered.

1.5.6 SIMULATION

Piloted and off-line simulation was essential to advance the understanding of the CAC. The study used simulation to accomplish four major objectives: 1) document the CV approach performance and FQ of legacy and current operational carrier-based aircraft; 2) investigate the sensitivity of selected aircraft characteristics on the CAC; 3) develop new candidate CAC; and 4) assist in identifying the substance and scope of follow-on research activities. For further information with regard to the facilities and methods used for the piloted and off-line simulation activities, refer to appendices C, D, and E.

1.5.7 TRADE STUDIES

Both JSF contract teams (Boeing and Lockheed-Martin) provided trade study data to support this study. These data in concert with the direct participation by representatives of both JSF contracting teams provided an in-depth understanding of industry design practices and how the CAC influence the overall aircraft configuration. Due to the proprietary nature of the trade study data, this information is not included in this report. All data contained in this report are nonproprietary.

1.6 CHRONOLOGY

The chronology of events concerning this study was as follows:

- | | |
|---------------------------------------|----------------|
| a) JSFPO request | November 1999 |
| b) Study Milestone and budgeting | December 1999 |
| c) First Joint CACS meeting | January 2000 |
| d) Approach Environment Decomposition | May 2000 |
| e) Second Joint CACS meeting | May 2000 |
| f) Third Joint CACS meeting | September 2000 |
| g) Report writing initiated | January 2001 |
| h) Fourth Joint CACS meeting | February 2001 |
| i) Phase I report completed | July 2002 |

CHAPTER 2: HISTORICAL REVIEW

2.1 INTRODUCTION

Since the first aircraft was converted to support operation from a CV, the approach task has been a challenge to both aircraft designers and fleet operators. Before any evaluation of the CAC could be conducted, it was first necessary to investigate the development history of these criteria to gain an appreciation of the reasoning, assumptions, and limitations of the CAC in order to ensure that informed judgments could be made of their relevancy and adequacy. Furthermore, based on the successful history of the USN in deploying acceptable carrier-based aircraft, the authors did not want to dismiss nor ignore lessons learned from prior analyses and assessments in the CAC development that would jeopardize this legacy.

Much of the development of the CAC was in response to demonstrated deficiencies encountered by past aircraft development programs. Additionally, with evolving mission requirements and advances in technology, the CAC was required to allow early assessment of an aircraft's capability in the design phase to maintain cognizance of program risk and progress. For Naval aviation to keep pace with these evolving requirements, the aircraft as well as the CV were required to evolve as a system, complementing each other such that the system as a whole provided capability far superior to that achieved through individual aircraft and CV capability improvements (e.g., heavier aircraft were made possible by stronger catapults and arresting gear). The joint adaptation of the CV and aircraft to meet continually emerging and advancing mission requirements is the reason aircraft define carrier characteristics, and in turn, carriers define aircraft characteristics.

A timeline of the development of Naval aircraft is presented in Appendix E. The Appendix E data were compiled using "United States Navy Aircraft since 1911" by Gordon Swanborough and Peter Bowers, Putnam Aeronautical Books, latest edition 1990, reference 5. The data were then compared and updated to reflect information provided in Navy issued Standard Aircraft Characteristic charts, the official historical document "United States Naval Aviation 1910-1995", reference 6, and other reports/documents found in files at the Naval Air Systems Command, Patuxent River, MD. A number of publications on specific aircraft were reviewed to establish a comparable Initial Operational Capability (IOC) date. The IOC dates reflected in Appendix E are defined based on the first squadron having received all aircraft and initiating work-ups for CV deployment.

2.2 FLAT-PADDLES APPROACH TECHNIQUE

The aircraft that have operated from carriers have often been extraordinary ones, expressing the conflicting requirements of speed and payload while achieving adequate low-speed FQ and airframe strength necessary for CV operations. World War II produced carrier-based propeller-driven aircraft including the Hellcat, Corsair, and Bearcat fighters, as well as the Helldiver and Avenger. These straight-winged aircraft approached straight-deck carriers using a "flat-paddles" approach technique controlled by the Landing Signal Officer (LSO), also referred to as "Paddles". This method of CV recovery had been in service since the early days of carrier aviation in the 1920's aboard USS LANGLEY (CV-1). These aircraft demonstrated an approach speed 5 to 10 kt above the aircraft stall speed.

As illustrated in figure 1, the LSO was stationed at the ship's stern, port side of the flight deck holding a colored paddle in each hand, giving a defined set of standardized signals to the pilot. The pilot flew the downwind leg on the port side at low altitude (nominally 150 to 200 ft) and when abeam, the LSO platform started a gradually descending turn, attempting to arrive at the CUT point (where the LSO signals the pilot to rapidly reduce throttle to the idle stop) on speed, at altitude, and on lineup with the carrier centerline. This technique required continual visual contact between the pilot and LSO from about the 90 deg position in the turn. Propeller-driven aircraft of this era did not provide sufficient FOV at approach attitude to allow visual contact with the LSO for a straight-in approach and starboard approaches would have encountered the burble generated by the ship's island.

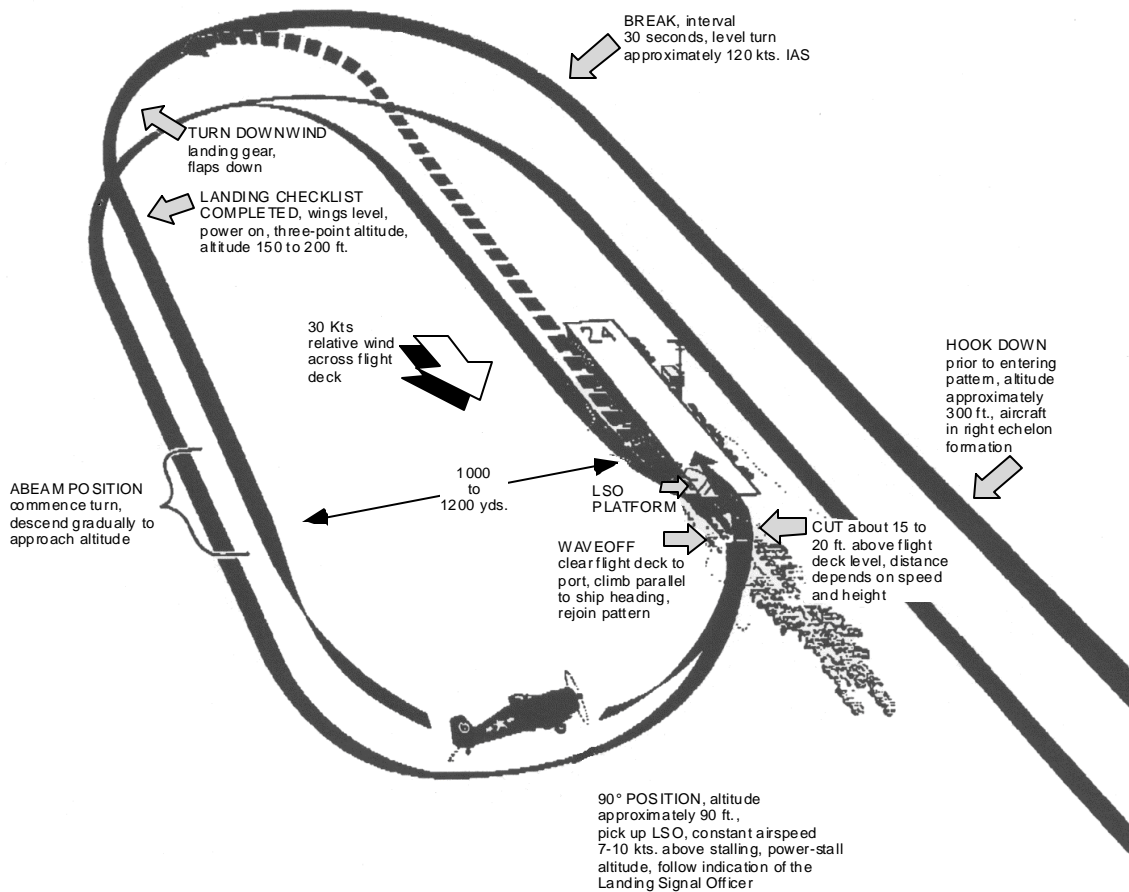

CARRIER LANDINGS in WWII were more art than science. All speeds and altitude were approximate "eye-ball" measurement and based on pilot's best judgement.

Figure 1: Carrier Landing Pattern for Propeller Aircraft (circa World War II)

The approach task was close-coupled to the LSO signaling. The LSO first corrected altitude (glide slope (GS)) by signaling whether the aircraft was HIGH or LOW. Attitude (and subsequently angle of attack (AOA)) would be addressed next by signaling FAST or SLOW. Lineup deviations would then follow by signaling LEFT or RIGHT of nominal. In addition, the LSO would signal for a HIGH DIP or LOW DIP if the aircraft was still high or low, but within tolerances for an engine chop (or

CUT). If the pilot were not within LSO tolerances, the pilot would be given the WAVE OFF signal requiring the pilot to go around for another attempt. The short, critical time period from release of LSO control to aircraft touchdown was hazardous because the variables in the landing transition were not always precisely controlled by the pilot.

The "flat-paddles" approach technique was the best available technique for the straight-deck carriers due to the limited touchdown area and the absence of a touch-and-go capability for salvaging long touchdowns (aircraft forward of the landing area precluded touch-and-go capability and were protected by a barricade). Through those years, the Vpa for these relatively lightweight, straight-winged, propeller-driven aircraft varied from about 60 to 90 kt and shipboard engaging speeds were generally quite low. This technique worked well for carrier aviation until the emergence of new mission requirements dictated development of carrier-based jet fighters, sophisticated subhunters, and medium bombers capable of carrying nuclear weapons. To meet these new requirements, variation in aircraft design and overall size resulted. This was primarily due to the point-design philosophy that existed at that time which focused an aircraft's design attributes to a specific mission requirement. As a result, wider variation in aircraft Vpa with a tendency for higher speeds resulted. Increased Vpa stretched the LSO-to-pilot communication system to its limits.

2.3 PROPELLER-TO-JET AIRCRAFT TRANSITION

During and immediately after the Korean War, jet aircraft with slow-responding engines and high approach speeds operated from straight-deck carriers; accidents were frequent. In addition, there was continuous pressure for larger carriers to support ever increasing Naval aviation mission requirements.

The first operational carrier-based jets (straight-wing) flew in 1948 at a recommended Vpa in the 100-115 kt range. For these aircraft, the limiting sink speed was 17 ft/sec and arresting gear limitation and/or aircraft structural considerations dictated engaging speeds in the 85-100 kt speed range. A longer and wider pattern provided the pilot sufficient time to effect proper lineup and approach altitude. However, the higher closing speed (relative speed between the aircraft and the carrier) reduced the time to marginally acceptable levels that the LSO could visually advise the pilot of his errors.

By 1948, the FJ-1 Fury and FH-1 Phantom, shown in figure 2, were in squadron service. When jets entered combat in Korea (1950-1953), the F9F Panther, F2H Banshee, and F3D Skyknight flying from USN CV and/or Marine bases were all straight-wing aircraft. These aircraft were outperformed by USAF and North Korean swept-wing fighters. Night fighters were still largely F4U-5N Corsair.



Figure 2: FJ-1 Fury (Left) and FH-1 Phantom (Right)

With the advanced USN jet programs delayed by changes in concepts and engine development problems, the Panther was redesigned into the swept-wing Cougar series while the Air Force F-86E Saberjet was adapted for carrier service as the swept-wing FJ-2/3/4 series. All-weather versions of the F2H Banshee series, meanwhile, had finally replaced the F4U-5N's in all-weather squadrons, figure 3.



Figure 3: F4U-5N Corsair (Left) and F2H-1 Banshee (Right)

Initial jet carrier-based operations proved dangerous with slow-responding engines and higher speed approaches. Time and experience showed that engine response was a strong player in determining CVS, especially during the approach, waveoff, and bolter phases. Quick responding turbojet engines proved their worth in the F-4 Phantom II and A-6 Intruder series making them excellent aircraft to approach and land aboard carriers. This became evident when the British switched to the Spey turbofan engine in the F-4K variant with a marked detriment in engine response and GS tracking during approach. The sluggish TF-30 engine response in the F-14A Tomcat was somewhat offset by Direct Lift Control (DLC) control. The F/A-18A/B/C/D Hornet with the small bypass ratio F404 turbofan ("leaky" turbojet) engine and digital engine control demonstrated excellent engine response during approach.

2.4 ROYAL NAVY INFLUENCES

It was in the early 1950's that the Royal Navy originated the ideas for the angled deck and the mirror OLS. The USN adoption of these innovations ultimately revolutionized carrier aviation and made possible the much safer operations of the high performance, swept-wing, supersonic tactical aircraft developed since the late 1940's. These same innovations coupled with tricycle-gear aircraft brought about the discontinuance of the "flat-paddles" technique and introduced the present day technique of a constant GS, constant AOA approach to touchdown. USN acceptance of the constant GS technique was part of a revolution in carrier landing procedures triggered not only by the advent of the angled deck and mirror optical landing aid, but by the belief that aircraft structural loads could be reduced or, at least, be held to a reasonably predictable range. A comparison view of a straight deck vs. angled deck is presented in figure 4.

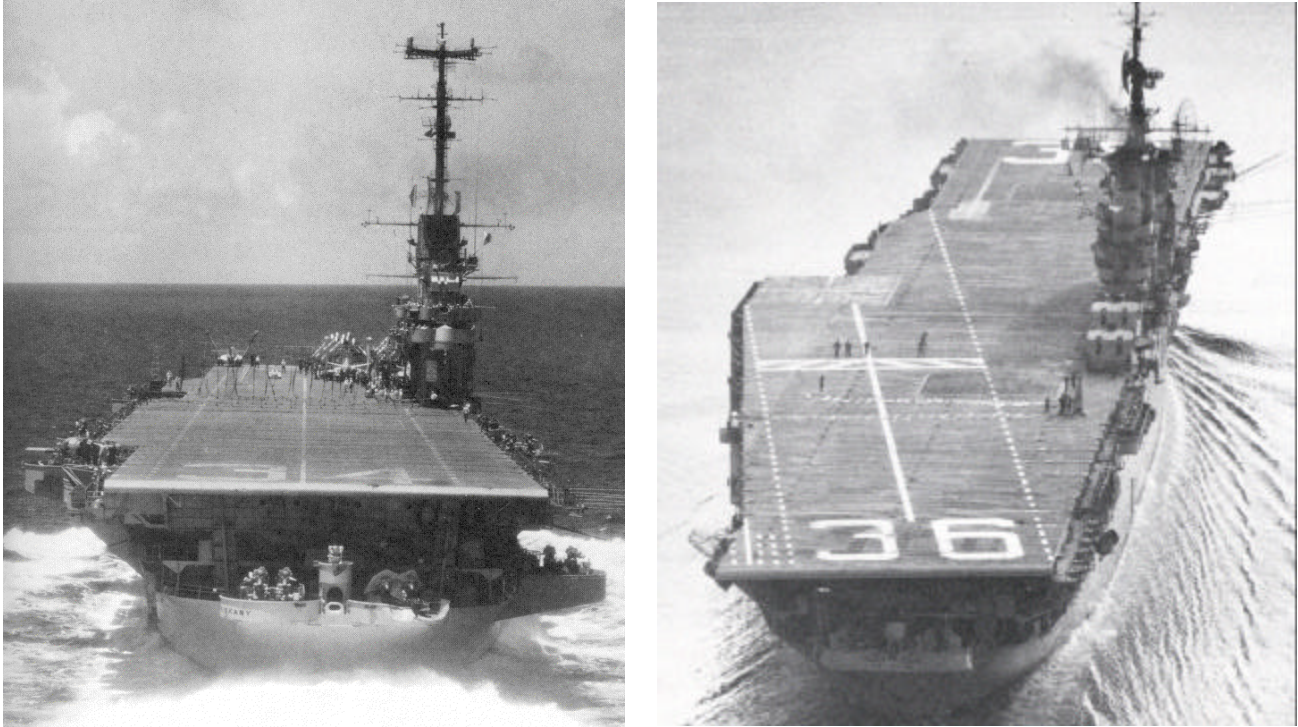

Figure 4: Straight Deck and Angled Deck Comparison View

The angled deck increased the latitude of the touchdown area to accommodate long landings and bolters. The mirror provided for a constant GS technique and, due to its larger size and greater illumination, provided elevation error information at ranges considerably greater than that which the LSO could furnish. The mirror did not provide the quantity of information equal to that of the LSO, but the absence of human error attributed to the LSO and greater cueing range were believed to outweigh any disadvantages incurred due to decreased information. In addition, the constant GS technique offered the following advantages:

- a) In descending on a GS, the pilot's FOV was improved due to the less nose-up attitude of the aircraft. An example FOV from the right seat of an A-6A is presented in figure 5.
- b) The area under the altitude versus range-to-touchdown curve (a measure of safety, particularly at night) was increased.
- c) The longer straightaway provided the pilot more time to stabilize airspeed thus reducing the incidence of aircraft or arresting gear failures due to excessive engaging speeds.
- d) The aircraft could be stabilized in the proper landing attitude and established on the proper landing sink rate early in the approach. The pilot maintained the landing variables at constant values and there was no need for the hazardous transition to landing.



Figure 5: USS FRANKLIN D. ROOSEVELT from an A-6A on Approach

However, in spite of these advantages, the advent of the high performance jet aircraft of the mid-1950's (with approach speeds of 120-135 kt) made it apparent that the new techniques with existing equipment were not adequate for shipboard operations, reference 7. This meant that carrier aviation was in a state of flux as these ideas were developed and implemented. Ships had to be modified, new techniques and procedures had to be developed, and existing and new development aircraft had to be adapted and designed for the new structural, aerodynamic, and propulsion requirements resulting from a substantially different method of shipboard operation. One of the significant ramifications of these changes was the necessity to reasonably predict V_{pa} for new aircraft design. Transition to jet aircraft and employment of the angled-deck carrier necessitated the prediction of V_{pa} . At that time, the primary driver for reliable V_{pa} prediction was to constrain the structural landing loads for design.

2.5 DEVELOPMENT OF APPROACH SPEED PREDICTION

2.5.1 MCDONNELL AIRCRAFT CORPORATION STUDY (1953)

The need for reasonable prediction of V_{pa} was becoming necessary even in the pure straight-deck carrier days of the early 1950's. The McDonnell Aircraft Corporation (MAC) became concerned when the XF-88A Voodoo (figure 6) and the XF3H-1 Demon aircraft both indicated that the minimum speed at which satisfactory aircraft response characteristics were available (minimum landing V_{pa}) was somewhat higher than the 110% of stall speed metric. This metric was considered a good estimation for landing V_{pa} at the time. Although flight at speeds below the determined minimum V_{pa} for both aircraft was possible, it was indicated that the pilot did not have the necessary control to rapidly make typical small flightpath corrections during the approach phase. It was also noted that at the speeds below the minimum V_{pa} , it was impossible to flare (typical of field landings) to reduce the rate of descent resulting in higher landing gear loads than design conditions. Although this was considered a field landing issue, an accurate prediction of V_{pa} to assess aircraft touchdown speeds was directly applicable to the CV approach problem as well.



Figure 6: XF-88A Voodoo

As a consequence of the higher than designed V_{pa} as determined from flight test, higher landing loads were encountered for these aircraft directly impacting the aircraft service life and potentially requiring significant aircraft redesign delaying fleet introduction. Therefore, to mitigate these concerns for future aircraft design activities, an improved understanding of V_{pa} requirements was warranted. MAC instituted a limited approach speed study, reference 8, which included limited quantitative flight tests.

The purpose of the MAC study was to aid in developing a method for estimating the minimum V_{pa} of an aircraft in the design phase. The study evaluated the effects of several variables on the minimum V_{pa} . This information was used to determine the primary factors that led to a method for minimum V_{pa} prediction using only a wind tunnel drag polar. Analytical studies, conducted as part of reference 8, attempted to predict the minimum V_{pa} using the lift curve, drag polar, and pitch damping but "yielded no conclusive or consistent results."

The MAC study focused on GS corrections required for adequate V_{pa} prediction. Flight tests were conducted using the XF-88A Voodoo aircraft using slow, medium, and rapid elevator motion resulting in flightpath response. From these data, a detailed investigation was conducted in an effort to develop correlating factors to aid in developing a method to analytically determine the minimum V_{pa} . Findings of this investigation are presented in table 1. These findings were used as the basis for a minimum V_{pa} predictive methodology. It should also be noted that no change in throttle setting was allowed during these tests and is, therefore, a key assumption in any application of these results.

Table 1: Key Findings from XF-88A Flight Testing

1	Normal flightpath correction that the pilots desired at minimum approach speed was 50 ft.
2	The ability to make this flightpath correction should only be limited by stall.
3	Regardless of the rapidity of the longitudinal input used, the pilots achieved the 50 ft altitude gain using approximately 43% of the maximum available load factor.
4	The maximum AOA or lift coefficient obtained during the 50 ft altitude gain (flightpath correction) is equal to the AOA or lift coefficient for level flight after completion of the altitude gain.

As part of the CAC's investigation, Mr. E. R. (Russ) Shields, the principal author of the MAC report, was contacted to gain additional insight into the activities at the time of the testing, reference 9. Mr. Shields stated that this pull-up maneuver was suggested by one of the test pilots who noted he had used such means of qualitatively deciding on a Vpa. However, it was not until quantitative flight test data were analyzed that the findings outlined in table 1 were determined. In addition, Mr. Shields also noted that at the time of the 1953 study, the UK ideas for the angled deck and mirror OLS were known, but since they were still in the early development stage, the MAC study, reference 8, only considered the straight-deck, flat-paddles approach.

Additional pertinent comments relating to the table 1 findings are:

- a) The 50 ft value was derived from data analysis, not direct pilot intent.
- b) Stall was the limiting factor. It was also noted that "...buffeting, wing drop or roll off, or any other adverse handling characteristics brought about by premature, asymmetric, or intermittent stalling characteristics were considered to be a basis for disqualification of that particular aircraft from the minimum approach speed study."
- c) The finding that 43% of available load factor achieved the 50 ft altitude gain was determined from the flight test data.
- d) Mr. Shields stated that the only reason for not using throttle in this maneuver was to "keep it simple" by introducing as few variables as possible.
- e) The importance of completing the maneuver with the same amount of lift that existed at the initiation of the maneuver was the key finding of the program.

Of great significance is that no time limit was mandated on achieving the 50 ft altitude gain in the maneuver. This implies that the fourth finding in table 1 serves as the basis for minimum Vpa prediction. In order for the maximum lift coefficient (C_{Lmax}) or AOA to produce 43% of the ΔN_z available between approach C_L and stall C_L :

$$L_1 \text{ must equal } L_2 \quad (1)$$

where L_1 is the lift at the initiation of the maneuver and L_2 is the lift at the point where 50 ft of altitude gain has been achieved. Accordingly,

$$C_{L_1} = \frac{W_1}{0.5 r_1 V_1^2 S_1} \quad \text{and} \quad C_{L_2} = \frac{W_2}{0.5 r_2 V_2^2 S_2} \quad (2)$$

Over the small time period and altitude difference involved, the following simplifying assumptions are made:

$$\begin{aligned} W_1 &= W_2 = W \\ \rho_1 &= \rho_2 = \rho \\ \text{and, of course } S_1 &= S_2 = S \end{aligned} \quad (3)$$

We now have:

$$C_{L_1} = \frac{W}{0.5rV_1^2S} = \frac{W}{0.5rS} \left(\frac{1}{V_1^2} \right) \text{ and } C_{L_2} = \frac{W}{0.5rV_2^2S} = \frac{W}{0.5rS} \left(\frac{1}{V_2^2} \right) \quad (4)$$

Therefore, because $\frac{W}{0.5rS}$ is assumed constant,

$$\frac{W}{0.5rS} = C_{L_1} V_1^2 = C_{L_2} V_2^2 \quad (5)$$

In this pullup maneuver, C_L is increasing with increasing α , and V is decreasing due to the drag increase as α is increased. Since the values of C_{L_1} , V_1 , and C_{L_2} are set to investigate a given speed and weight, it is necessary to find the combination such that the speed loss in the maneuver yields:

$$V_2 = \sqrt{V_1^2 \frac{C_{L_1}}{C_{L_2}}} \quad (6)$$

Since the key to this determination is the speed loss, which is a direct function of the drag increase with increasing C_L , the MAC methodology uses the drag polar.

The conclusions from the MAC study included (reference 8):

- a) "From the rather limited data, it appears possible to estimate the minimum V_{pa} of an aircraft within three knots using wind tunnel test data."
- b) "Accuracy of the presented method for determining minimum V_{pa} is entirely dependent upon use of an accurate aircraft trimmed drag polar. Therefore, particular emphasis is placed on using the most accurate drag data available."
- c) "Additional flight investigations on other aircraft configurations are desirable to further verify the method presented for the estimation of minimum V_{pa} ".

2.5.2 NATIONAL ADVISORY COMMITTEE FOR AERONAUTICS APPROACH SPEED STUDY

About 5 years after the MAC 1953 study, the National Advisory Committee for Aeronautics (NACA) reported, through reference 10, the results of a flight test program that compared flight-measured V_{pa} to predictions for 41 fighter-type configurations. The motivation for the study was essentially the same as given earlier by reference 8. For this study, NACA used 4 pilots and 10 basic aircraft (5 USN and 5 USAF) and used various modifications to high-lift devices to achieve 41 configurations. Use of Boundary Layer Control (BLC) to reduce both stall speed (V_s) and V_{pa} was a main feature of the study.

While considerably more extensive than the MAC study, the NACA study did not obtain quantitative data to assess any specifics of how the four pilots actually determined the minimum V_{pa} . Nevertheless, they determined V_s , lift and drag polars, and thrust required across the V_{pa} range. The report states that for the pilot determination of V_{pa} , carrier type approaches were made. These are defined as relatively constant airspeed, high thrust level to maintain steady flight, and a low GS of 0 to 2 deg. These GS's were representative of the flat paddles approach. The statement is also made that for a few configurations, supplementary evaluations were made with the mirror approach technique using a GS of 3.25 deg.

The study used eight prediction methods for minimum V_{pa} . As used in the report, this minimum "comfortable" V_{pa} was the lowest trimmed speed that the pilot would deliberately use. These eight prediction methods are presented in table 2.

Table 2: Eight Prediction Methods for V_{pa} from NACA Report

1	1.15 $V_{s_{CL_{max}}}$ where $V_{s_{CL_{max}}}$ is based strictly on aerodynamics, no allowance for thrust effects.
2	1.15 $V_{s_{pa}}$ where $V_{s_{pa}}$ now includes thrust effects
3	1.15 $V_{s_{Pilot}}$, where $V_{s_{Pilot}}$ is the average stall speed reported by the pilots.
4	Flightpath angle (FPA) rate of change of 0.060rad/sec.
5	MAC method previously discussed.
6	$V_{D_{min}}$, the speed for minimum drag.
7	L/D max, the speed for maximum lift to drag ratio.
8	$V_{HP_{min}}$, speed for minimum power (not thrust) required. A factor of 1.08 was used with this speed to give the best agreement with the flight results obtained in this study.

The flight program produced five basic categories of pilot reasons for calling the minimum "comfortable" V_{pa} .

- a) Ability to control altitude
- b) Stall proximity
- c) Unsatisfactory lateral-directional (stability or control) characteristics
- d) Visibility (FOV)
- e) Combinations of the above

For comparison of flight derived and prediction of minimum V_{pa} , NACA determined that an acceptable criterion was prediction of V_{pa} within 5 kt of the average flight values of all applicable configurations. None of the eight criteria used were successful in meeting the 5-kt criterion. The closest agreement was obtained using 1.15 $V_{s_{pa}}$ and with a modified form of the MAC method. This modification was to subtract 2 kt from the MAC calculation. This is in addition to the 2 kt reduction for thrust already used in the MAC method.

As in the case of the MAC method, the NACA effort had characteristics other than fundamental lift and drag that were identified as causing selection of higher V_{pa} than predicted. As enumerated in

reference 10, these were unfavorable stability and control characteristics, poor visibility, insufficient engine thrust available for maneuvering, and sharp increase in the unstable slope of the drag versus airspeed (thrust required) curve. This last item alludes to one of the major findings of this study: that flight on the back-side of the thrust required curve does not in and of itself impose a limitation on the approach speed. However, it was noted that limiting conditions on back-side flight remain to be defined, reference 10.

Following this program, NASA (previously NACA) produced a memorandum containing an analysis of the test results that discussed the factors that influence the choice of V_{pa} from the pilot's perspective. A piloting technique found to be "highly desirable" for flying the approach in high performance aircraft was the back-side technique. This entails using thrust changes to adjust the flightpath while keeping the airspeed (or AOA) relatively constant with longitudinal stick, reference 11.

2.5.3 STALL MARGIN CRITERIA EVOLUTION

Stall margin at one time was a key parameter used by carrier aircraft designers in determining V_{pa} . In the 1950's, it was generally assumed that a V_{pa} with reasonable margin over stall would capture the stability-and-control and performance characteristics of an aircraft required for a pilot to manage a low-workload CV approach and recovery. In 1953, MIL-A-8629, reference 12, required a V_{pa} of $1.2 V_{SL}$, based on a power-off calculation of V_s . However, about this time, industry was beginning to use a V_{pa} based on a power-on stall margin ($1.2 V_{Spa}$). It was rationalized that including the vertical thrust component from the power required to trim on GS in determining $C_{L_{max}}$ was more realistic. Although this in theory enabled a lower V_{pa} , data from the fleet later showed it to be lower than the comfort level of the pilots. Statistical data showed a V_{pa} of $1.3 V_{Spa}$ more representative of that actually used by the fleet. It was also learned that the margin over stall used by pilots in the fleet varied between aircraft models.

Recognizing the aircraft model-specific dependence of V_{pa} and the absence of a correlation with V_s , in 1960, the Requirements for Aircraft Strength and Rigidity (MIL-A-8860), reference 13, was issued defining $V_{pa_{min}}$ as the "minimum usable airspeed for carrier landings." It was also specified that $V_{pa_{min}}$ "shall be determined by methods acceptable to the Bureau of Naval Weapons, shall be as approved by the Bureau of Naval Weapons, and shall be as demonstrated by appropriate flight tests." Note that a "minimum usable airspeed" was defined. About this same time, the requirements for Ground Loads for Carrier-Based Aircraft, Aircraft Strength and Rigidity (MIL-A-8863), reference 14, specified the design V_{pa} to be 110% of $V_{pa_{min}}$. However, there was no consensus methodology for either estimating $V_{pa_{min}}$ for design or measuring $V_{pa_{min}}$ in flight test resulting in considerable confusion. However, the following criteria were generally used for defining $V_{pa_{min}}$:

- a) $V_{pa_{min}} > 1.1 V_{Spa}$
- b) Adequate visibility on GS and at intercept
- c) Adequate handling qualities
- d) Compatibility with WOD requirements

- e) Level-flight longitudinal acceleration capability of 5 ft/sec^2 within 2.5 sec in MIL power
- f) 50 ft GS transfer in 5 sec with pitch stick only (popup)
- g) 500 ft/min single engine rate of climb on a tropical day

Some designers believed that if not constrained by visibility, the popup maneuver had the most significant impact to the design. A 2-DOF calculation of the popup maneuver using an AOA increment corresponding to one half the incremental load factor available at initiation of the maneuver typically yielded a $V_{pa_{min}}$ of approximately $1.18 V_{S_{pa}}$. Thus, $1.1 \times 1.18 V_{pa_{min}}$ resulted in a V_{pa} of $1.298 V_{S_{pa}}$. This was in good agreement with the statistical fleet survey data of $1.3 V_{S_{pa}}$ and the popup was considered firmly established.

However, confusion still prevailed because a standard method for calculating the popup maneuver was not defined. The instantaneous pitch rotation assumed in the 2-DOF calculations was unrealistic. Simulating the pitch rate with a ramp input in the 2-DOF resulted in a higher $V_{pa_{min}}$ and applying a factor of 1.05 resulted in closer agreement with the V_{pa} used in the fleet. Digital computation capability was improving rapidly and the ability to simulate the popup maneuver followed suit. Soon there was the ability to include the details of the flight control system in a 3-DOF simulation of the popup maneuver and improved agreement with the fleet surveyed approach speeds emerged.

2.5.4 U.S. NAVY CONTRIBUTIONS 1959-1968

2.5.4.1 Research Efforts

On 15 January 1959, J.E. Linden of the Aerodynamics and Hydrodynamics Branch of the Bureau of Aeronautics (BUAER) published Technical Memorandum 1-59 titled "A Discussion of the Carrier Landing Approach Speed Problem," reference 15. Reference 15 discusses the need for an accurate means of predicting V_{pa} early in the design because of its implications for aircraft strength, recovery WOD, and FQ. Citing the MAC 1953 (reference 8), NACA 1958 (reference 10), and NASA 1958 (reference 11) reports, it summarizes the factors that influence V_{pa} :

- a) The ability to control altitude in the approach
- b) Proximity to stall
- c) Visibility
- d) Stability and control characteristics
- e) Ability to waveoff
- f) Speed for minimum drag

Reference 15 concludes:

- a) The criterion of 1.3 times the power approach stall speed is inadequate.
- b) The techniques for height control (throttle versus longitudinal stick) should be fully explored, including a determination of satisfactory engine thrust response characteristics.
- c) The use of the MAC method for estimating V_{pa} appears satisfactory for those cases where speed is limited by the ability to control altitude.
- d) Insufficient justification existed for stall margin criteria and aircraft configuration dependencies were not well understood.

On 6 February 1959, the Stability and Control Section at the BUAER originated a project at the Naval Air Test Center (NATC) with BUAER Confidential letter Aer-AD-32 serial 01184, reference 16. The purpose was to determine practicality and usefulness of the throttle as compared to the stick for primary control of flightpath during the approach. The result of this project was reported by NATC "Effects of Pilot Technique on Minimum Approach Speed, Report No. 1, Final Report", reference 17. Reference 17 presents three aircraft control strategies based on various operating regions of the thrust-required curve (see figure 7):

- a) For the front-side, "slight" increases or decreases in AOA using longitudinal stick control without changing thrust allows the pilot to bracket his AOA and FPA without using thrust. This results in a more easily executed CV approaches than on any other portion of the thrust-required curve.
- b) In the bucket, small variations in throttle (or longitudinal stick) can cause unacceptably large changes in airspeed. Pilots found that approaches performed in this region were more objectionable than any other portion of the thrust required curve.
- c) On the back-side, use of the throttle is mandatory, and the approach is difficult to execute with precision.

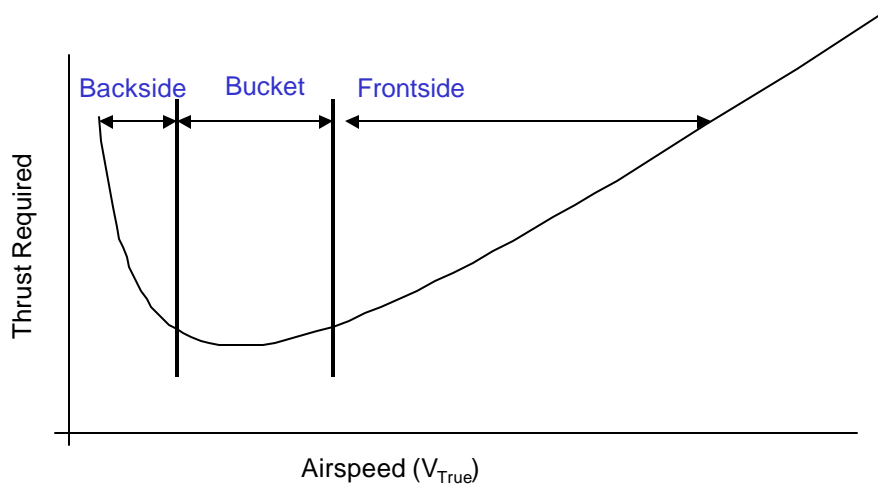

Figure 7: Illustration of Three Regions of the Thrust Required Curve

The key word in the front-side region is "slight." More than slight will still require a thrust change and a return to approach AOA with the stick. The key word in the back-side region is "precision". On the back-side, even "slight" changes in AOA require a thrust change and make it more difficult to be precise.

Reference 17 concluded that the primary factors in establishing the role of stick and throttle were:

- a) Shape of the thrust-required curve and location of operation on the thrust curve
- b) Effectiveness of longitudinal stick in making height changes
- c) Effectiveness of throttle in making height changes

About the same timeframe, an article by an NATC CV test pilot, "Determination of Optimum Approach Speeds for Carrier Landings" appeared in Naval Weapons Bulletin No. 3-61, reference 18. In some ways, this article improves on reference 17. It has a more detailed and lucid discussion on controlling height and speed in the three regions of the thrust-required curve. Further discussion of height control and speed is addressed in Section 2.5.4.4.

In 1963, Bureau of Weapons (BUWEPS) Problem Assignment RAD33-210, reference 19, requested NATC evaluate the V_{pa} criteria. The V_{pa} criteria were defined at that time as:

"The minimum usable approach speed, V_{PAmin} , is the minimum repeatable airspeed in the landing configuration which can be maintained within \pm five (5) knots from inception of approach to deck contact, the aircraft remaining within the envelope defined by the optical landing aid system with a mirror setting of four (4) degrees and:

- a) A longitudinal acceleration of at least five (5) ft/sec^2 in level flight at zero FPA will be available on a hot day (90°F) within 2.5 seconds after initiation of throttle movement to the military thrust position while in a speed stable approach at $V_{pa_{min}}$.

- b) The speed shall not be less than $1.1 V_{spa}$.
- c) Visibility and ground clearance will be adequate.
- d) Stability and control requirements of applicable detail specification will be satisfied.
- e) The aircraft shall be capable of making an altitude correction from stabilized flight at $V_{pa_{min}}$ on a four (4) degree glide slope to a new altitude fifty (50) feet above the initial flightpath and will be capable of maintaining this new flightpath upon completion of the maneuver. The aircraft will have climbed to or above the new altitude within five (5) seconds after initiation of the maneuver. The maneuver will be performed without change in engine thrust and the maximum incremental load factor during the maneuver will not exceed one-half (1/2) of the incremental load factor which would be attained by rotation to steady state $C_{L_{max}}$ at $V_{pa_{min}}$."

Based on discussion with J. E. Linden, reference 20, it was concluded that the criteria were based on a survey of pilot opinion. Responding to the BUWEPS Problem Assignment RAD33-210, NATC Report No. FT-27R-66, reference 21, reported that test results of F-4, F-8, A-4, RA-5C, and A-3 evaluations reported the criteria are suitable for defining $V_{pa_{min}}$, could be demonstrated, and should be incorporated as design criteria for carrier-based aircraft. Reference 21 also recommended minor changes to the criteria. The primary conclusions impacting the GS transfer (popup) criteria were:

- a) Longitudinal acceleration and popup criteria are more meaningful when demonstrated from the GS instead of from level flight.
- b) The configuration, center of gravity (CG) location, and store loading of the aircraft should be specified in the $V_{pa_{min}}$ guarantee.

Other conclusions were adequate FOV and ground clearance which were not defined by the criteria for $V_{pa_{min}}$. Referring to the popup maneuver, the report states:

- a) use of Approach Power Compensation (APC) should not be allowed,
- b) minimum acceptable stabilized airspeed following interception of the second GS should be $V_{pa_{min}}$ minus 5 kt, and
- c) AOA should not exceed stall warning.

In August 1967, G. A. Patterson, Jr. of NATC summarized the critical development in a paper titled "Criteria for Determination of Minimum Usable Approach Speed", reference 22, at the American Institute of Aeronautics and Astronautics (AIAA) Guidance, Control and Flight Dynamics Conference in Huntsville, Alabama. Reference 22 stated that: "In the past the minimum and/or optimum approach speeds have been determined qualitatively. This did not provide a quantitative base from which desirable and undesirable characteristics could be assessed. Subsequently, six major factors are isolated as the basis for determining the minimum usable approach speed; these

factors were: longitudinal acceleration available, stall speed, field of view from the cockpit, ground clearance, stability and control requirements, and glide slope correction capability. All new carrier-based aircraft plus a few already flying, must comply with the stated requirements for establishing minimum usable approach speed. Additional experience will be required to finally conclude that the values of the requirements are valid ... Also, some consideration is needed for other factors which affect height control.”

Interviews with former BUAER/NAVAIRSYSCOM aeromechanics leaders, reference 20, indicated that the CAC were intended to be used as design aids and were not intended to replace pilot determination of V_{pa} . The fact that the CAC evolved as the standard by which demonstration of V_{pa} is validated is at odds with the original intent of the criteria in that V_{pa} was to be determined in flight test independent of the design criteria.

2.5.4.2 Navy A-7 Experience

The first Request for Proposal (RFP) that included wording similar to that of reference 22 was the VAX (experimental light attack aircraft, later designated A-7) RFP in 1962. Two significant changes from the criteria as listed in reference 22 appear in the Detail Specification for the A-7E Aircraft, SD-555-5, 21 March 1968, reference 23.: “...longitudinal acceleration of at least 4.5 ft/sec^2 ...” and “... the aircraft must be capable of executing a 50 foot step-up from level horizontal flight in less than 7.0 seconds, and have the ability to maintain level flight at the new altitude.”

2.5.4.3 Navy A-6 Experience

In 1965, the Grumman Report XA128-105-18, the A-6A Aircraft Substantiation Data Report, reference 24, stated:

"The A-6A was originally designed for an approach speed equal to 1.3 times the power approach stalling speed. More recently, a new criteria for approach speed has been established as $1.1 V_{pa_{min}}$, where $V_{pa_{min}}$ is defined as follows:

- a) A longitudinal acceleration of 5 ft/sec^2 within 2.5 sec of throttle movement.
- b) The speed shall not be less than $1.1 V_{spa}$ [the power on stall speed].
- c) Visibility and ground clearance will be adequate.
- d) Stability and Control characteristics shall meet the requirements of MIL-F-8785.
- e) The aircraft will be capable of making an altitude correction from stabilized flight at $V_{pa_{min}}$ to a new altitude 50 feet above the initial flightpath. The aircraft will have climbed to or above the new altitude in 5 seconds after initiation of the maneuver. The maneuver shall be performed without change in the thrust settings, and the maximum positive incremental load factor during the maneuver will not exceed 50% of the delta load factor available. The maneuver will be considered complete when an altitude correction of 50 feet has been reached. After completion of the maneuver, the aircraft be capable of maintaining a new

flightpath at least 50 feet above the initial flightpath with the pilot permitted to change the thrust setting as required."

The Grumman comparison of the old criterion, 1.3 times stall speed, versus the new criterion showed only 1 kt difference ($1.1 V_{pa_{min}}$ being higher) at 40 deg flaps and 3 kt different (same trend) at 30 deg flaps.

2.5.4.4 "Backside" Technique

References 10 and 11 make the earliest specific reference found in this investigation to what is called the "back-side" technique. Subsequently, the NSC published a document in June 1959 titled "Final Approach" in which the back-side technique is strongly recommended, reference 25. Starting with the simplified equation used in the NASA memorandum, reference 11, it shows how the back-side technique works everywhere on the thrust-required curve, while the "front-side" technique of controlling flightpath primarily with the longitudinal stick and airspeed primarily with thrust works over a limited range of the thrust-required curve (see figure 7).

"Aerodynamics for Naval Aviators" published in January 1960, reference 26, provides a detailed discussion of controlling altitude with the throttle and airspeed with longitudinal stick. A July 1961 "Approach" magazine article titled "The Carrier Landing Story", reference 27, and a February "Approach" article titled "Ramp Strike", reference 28, both use examples from the "Final Approach" publication to further reinforce the back-side technique. Finally, in a March 1965 two-part article in Approach periodical titled "The Total Approach", reference 29, CDR R. M. Netherland detailed how the GS should be flown (without APC). Although written specifically from A-4 experience, the article provides rationale for flying the back-side technique regardless of thrust response or inclination, and regardless of longitudinal response and control power. Reference 17 stresses that while throttle and longitudinal stick are not the only controllers of altitude and speed, respectively, they are the primary controllers. Each aircraft/engine/flight control system combination and each pilot will introduce both controllers to effect corrections in the transient, but always attempt to achieve the desired steady-state condition of GS and airspeed with the primary controller of each.



Figure 8: F8U Crusader and F4D-1 Skyray

Reference 18 discussed flight test results for the F8U and F4D-1, figure 8. The aircraft were flown throughout the approach speed range to determine if flightpath corrections could be made using

longitudinal stick while maintaining constant thrust (front-side technique), or if flightpath corrections could be made by changing thrust while holding constant AOA (back-side technique). Reference 18 revealed, "The pilot instinctively attempts to make glidepath [flightpath] corrections initially with longitudinal control only." This makes it highly desirable that sufficient flightpath control capability be available at constant thrust using small changes in AOA (approximately 1-2 degrees)." Thus, some inherent stall margin must be available for flightpath control.

In the bucket of the thrust-required curve, small changes in AOA yielded large changes in speeds. In contrast, reference 18 stated, "When the thrust adjustment technique is employed, a stabilized condition or flightpath is virtually impossible to attain." This is due to the slower response of flightpath to throttle movement that also leads to the tendency to over-correct in attempting to achieve the desired correction. Thus, it is difficult to determine the thrust setting for a given flightpath. Consequently, the pilot is continually making adjustments in throttle. Since a true back-side technique did not prove adequate for operation in the bucket, a combination of the two techniques was used in which longitudinal stick was used for short-term flightpath response in conjunction with throttle inputs. Reference 17 found that "This technique produces the necessary rapid corrections on flightpath although it requires precise coordination throughout the control procedure."

2.6 APPROACH SPEED CRITERIA EVOLUTION

2.6.1 GLIDE SLOPE TRANSFER (POPUP) MANEUVER

The GS transfer maneuver (50 ft popup in 5 sec with no throttle changes) was one of the first criteria derived to replace multiple stall speed criterion that attempted to correlate with pilot recommended "minimum comfortable approach speed". The concept originated from a study performed by the McDonnell Aircraft Company in 1953, reference 8. BUAER used the current form of the criterion in 1962 in the VAX RFP (VAX became VAL, or A-7, in 1963) which was the first application of the GS transfer maneuver criterion.

Additional considerations of the popup maneuver include the use of DLC and the definition of C_{Lmax} . The F-14A Detail Specification SD-561-1, reference 30, added the footnote regarding use of DLC which stated, "DLC devices, if provided, shall be assumed to be in the stowed position throughout this maneuver." Therefore, credit for DLC was not permitted in the popup calculation.

Significant lift at maximum lift AOA generated leading edge extension (LEX) and strake vortex flow designs made it necessary to further define lift beyond wing stall which had direct implications to the available load factor (stall speed) that could be used for the popup calculation. The revised stall speed definition is found in reference 1, "Although the local slope of the curve of lift coefficient vs. AOA should be at least zero or positive at all points less than C_{Lmax} . A slightly negative local slope may be permissible if it can be shown by engineering analysis and simulation, and eventually verified by flight test, that no unsatisfactory FQ and/or performance characteristics will result."

2.6.2 FIELD OF VIEW

Until shortly after the Korean War, USN carrier-based aircraft operated on straight-deck carriers. The CV approaches, day and night, were level, circling at a low altitude. As the stern of the ship was approached, pilots were controlled by a LSO to touchdown. For propeller-driven aircraft with large engines and tailwheels, the over-the-nose FOV was much more restricted than current aircraft. Pilots typically would fly a flat pass, turning all the way to exploit the improved FOV from the side. The straightaway portion of the approach was short.

During the mid 1950's, the advent of the angled-deck carrier, the tricycle-gear aircraft and the adoption of the mirror OLS brought about the present day technique of constant speed (AOA), constant GS approaches to touchdown. Extended straight-in portions of the approach increased the importance of FOV.

The FOV criterion was examined through tasking from BUWEPS in 1963, reference 19. After evaluating the criterion, NATC recommended in 1966, reference 21, that the FOV criteria be changed to "Adequate field of view, pilot position should assure safe ejection" and that "Adequate" be defined. The need for a quantitative, demonstrable requirement led to the FOV criterion as defined in reference 1. The first known application of the current FOV criterion was used in the F-14A detail specification in 1969, reference 30. The requirement has been in effect without modification since that time.

The flight condition specified is 600 ft AGL, in level flight, on a 4-deg optical GS. It is noted that this flight condition is seldom encountered during nominal WOD conditions. The specified flight condition provides a FOV that will only improve during normal operations. This implies that the criterion is conservative during nominal WOD operations. This conservatism seems to be justified since, even with aircraft meeting the criterion, pilots typically raise their seats to the maximum available height to improve FOV. Three possible reasons that support the definition of the FOV criterion have been proposed.

First, the FOV condition approximates the picture a pilot would see during operation at very high WOD. The 4-deg GS is generally not used unless the WOD is greater than 30 kt. As WOD increases, the vertical velocity of an aircraft on a given GS decreases, the limit of which is approximated by the level flight condition.

Second, it was suggested that flight condition is related to night Emergency Condition (EMCON) recovery procedures. The CV Naval Air Training and Operating Procedures Standardization (NATOPS) Flight Manual (NAVAIR 00-80T-105), reference 31, describes night EMCON recovery procedures in Section 5.4.10.1: "Aircraft will descend in accordance with air wing doctrine to not lower than 600 feet, which will be maintained until the ball is in sight." This straight-in approach pattern will result in the flight condition specified in the FOV criterion if a 4-deg GS is employed.

Third, the RA-5 NATOPS Manual (1977), reference 32, shows GS intercept for a standard Visual Flight Rule (VFR) approach at 600 ft, followed by a pushover. It is not believed that this technique was typical of other aircraft.

The requirement to see the waterline at the stern appears intended to guarantee that the pilot has adequate lineup information from the drop line. The drop line will recede from view at some point during the approach no matter what the FOV. As the aircraft approaches the stern of the ship, more of the drop line becomes obscured, but the lineup information provided by the aspect of the flight deck becomes more acute providing the necessary lineup cueing required.

2.6.3 LEVEL I FLYING QUALITIES

2.6.3.1 General Flying Qualities

The first known set of FQ criteria was the NACA Wartime Report, “Requirements for Satisfactory Flying Qualities of Airplanes” (Gilruth, 1941), reference 33. In the 1950's, the USN adopted Military Standard MIL-F-8785, reference 34. As advances in aerodynamics, propulsion, and control systems occurred, the military standard was revised several times to keep pace with technology, references 35 and 36. In the 1990's, MIL-STD-1797A, Military Standard Flying Qualities of Piloted Aircraft, reference 37, was released as the FQ standard for all military fixed-wing aircraft. Because there are many FQ criteria that apply to the approach task, each with its own history, a full review of all of the relevant criteria was determined to be beyond the scope of this report. Therefore, only two specific analytical criteria were examined in detail in this report: roll control and flightpath stability.

2.6.3.2 Roll Control

A roll response criterion first appeared in reference 33 that defined it as “the maximum rolling velocity obtained by use of ailerons alone should be such that the helix angle generated by the wing tip, $pb/2V$, is equal to or greater than 0.07, where p is the maximum rolling velocity in rad/sec, b is the wing span, and V is the true airspeed in ft/s.” The criterion did not differentiate between up and away and power approach. MIL-F-8785-4, released in 1959, reference 34, updated this criterion. This criterion called for Class III aircraft in power approach configuration to possess an average $pb/2V > 0.05$ for the first 30 deg of bank angle change. In the 1960's, roll performance began to be expressed in amount of bank angle change over time. The change was based on research conducted in the late 1950's by Princeton using the NAVION to represent Class IV aircraft, reference 38. This research recommended a threshold of 30 deg angle-of-bank (AOB) change in 1.0 sec. MIL-F-8785B, reference 35, followed approximately 10 years later with a criterion of 30 deg AOB change in 1 sec for Level 1 FQ, and 30 deg in 1.3 sec for Level 2 FQ. For Class IV aircraft, a roll mode time constant requirement of $\tau_R < 1.0$ sec was added. In MIL-F-8785C, reference 36, the Level 1 threshold was relaxed to 30 deg of bank angle change in 1.1 sec. Designers believed that the 30 deg in 1.1 sec criterion was too restrictive, and F-4 flight data suggested that this lower level of roll performance was acceptable.

The USN invoked the more restrictive 30 deg in 1-sec threshold for the F/A-18E/F and Naval Advanced Tactical Fighter design specifications. Furthermore, the F/A-18E/F specification attempted to guarantee a graceful degradation of roll performance at higher AOA. In addition to the roll requirement at the approach AOA, constraints were also added to specify roll performance at the approach AOA +2 deg and approach AOA +4 deg. The change was implemented as a result of concerns regarding roll performance at speeds below V_{pa} that were not adequately specified.

2.6.3.3 Flightpath Stability

Flightpath stability is defined in this report as the steady-state flightpath response to an attitude change. For an aircraft trimmed on GS in power approach (which can be on the back-side for USN aircraft), an AOA change equates to a speed change for a fixed thrust setting. Hence, flightpath stability is mathematically described as dy/dV . Flightpath stability has also been termed “airspeed stability” and was first addressed using this nomenclature in 1961 in reference 17. Approximately 7 years later, the first documented flightpath stability requirement appeared in reference 30: “. . .at V_{omin} [i.e., V_{PAmin}] . . . the climb angle versus airspeed curve shall not have a local slope more positive than 0.10 deg/knot. Further, the slope shall not vary more than 0.05 deg/knot within 5 knots of the trim airspeed.” The requirement was first updated to the MIL-STD-1797A, reference 37, threshold values in MIL-F-8785B, reference 35, in 1969.

2.6.4 STALL SPEED MARGIN

Stall speed margin is the oldest CV approach criterion and is the only criterion dating to the pre-World War II era. When propeller aircraft landed on straight-deck carriers using the "flat-paddles" approach technique, the approach criterion required the approach AOA provide no less than 1.05 to 1.10 times the aircraft stall speed. With the introduction of straight-wing jet aircraft to the carrier in the early 1950's, MAC and BUAER realized that "comfortable" V_{pa} as determined by flight test was higher than 110% of the aircraft stall speed. As stated in Section 2.5.4.3, the A-6A was designed for 130% of $V_{S_{pa}}$ (the power approach stalling speed), which provided a reasonable estimate of the approach speed relative to stall speed based on historical data. Later in the A-6 development program, formal criteria were implemented in the definition of V_{pa} including direction that at least a 10% margin must be maintained to stall. At that time, $V_{pa_{min}}$ was utilized and an additional 1.05 margin was applied to $V_{pa_{min}}$ to determine V_{pa} . The 1.05 factor traditionally applied to $V_{pa_{min}}$ to determine V_{pa} was subsequently removed after review of landing speed survey data.

2.6.5 FLIGHT CONTROL LIMIT SPEED

As early as the YF-16 and YF-17 programs in the early 1970's, the USN had considered the use of AOA limiters in the power approach regime. It was not until the A-12 program in the late 1980's that an AOA limiter was explicitly authorized in the vehicle design specification in gear/flaps down operation. Unfortunately, there was no elaboration on how such a limiter was to be defined, what criteria would be used to establish it, and how it should be interpreted relative to performance speed definitions like V_{pa} . These shortcomings were addressed to a certain degree in reference 2 through the incorporation of Flight Control Limit Speed (FCLS) into the V_{pa} definition. Issues relative to the limiter criteria definition remain pertinent.

Allowances for an AOA limiter were made due to the recognition of the relatively small operating envelope required for satisfactory launch and recovery operations. It should be noted that the FCLS should not be confused with the catapult launch criterion that precludes sustained saturation of the control devices during the rotation or AOA/pitch attitude capture. An AOA limiter may be a more cost effective solution to address undesirable aerodynamic or control deficiencies at higher AOA's. Aerodynamic or control system optimization in a region of the envelope where the aircraft is not intended to routinely operate except for developmental flight testing was acknowledged to be

unnecessary and cost-prohibitive. However, the higher AOA's typically seen during catapult launch operations may not allow the adoption of an AOA limiter except at AOA's well beyond the fly away AOA (~14 - 15 deg).

2.6.6 THRUST RESPONSE

Two of the most significant characteristics for a carrier suitable aircraft are thrust response and excess thrust available. The rapid response of the large radial engines of World War II gave the carrier-based aircraft quick response waveoff capability that was needed for the flat-paddles approach technique. The limited stall margin present in the initial jet engines severely hampered achieving adequate thrust response that was required for safe and efficient approaches. This problem was compounded with the introduction of swept-wing aircraft configurations that increased approach and closure speeds, which reduced the time available for the pilot to respond to deviations from GS as provided by the LSO.

Before the advent of electronic engine control, the hydromechanical fuel control consisted of cams, springs, levers, and diaphragms. These controllers typically provided engine control functions such as speed governing, temperature, and altitude compensation, scheduling of variable guide vanes, and overspeed protection. Reprogramming the fuel control was accomplished by adjusting setscrews, replacing springs, or machining new multidimensional cams whose shape captured a particular control schedule. The simple, but bulky, hydromechanical controls have given way to hydromechanical computers, analog electronics, and modern digital electronic controls, including full-authority digital engine control (FADEC). FADEC provides complete dual-redundant computer control of the engine without mechanical backup. The advent of FADEC established new standards in safety, functionality, and engine handling across the flight envelope. Engine electronic control, the heart of FADEC, is capable of total powerplant management from engine start to maximum power. It provides a powerful airframe interface for engine control, parameter display, health monitoring, and maintenance functions.

In 1992, eight LSO's located at the NATC Strike Aircraft Test Squadron rated CV approach characteristics and boarding rate of fleet aircraft. The jet aircraft with accompanying comments regarding engine response follows (best aircraft rated first): (a) F/A-18, excellent engine response; (b) S-3A, good engine response; (c) A-6E, fairly good/positive engine response, (d) EA-6B, fairly good engine response; (e) A-7E, underpowered; and (f) F-14A, long engine spool up time. The rating is directly related to the engine response characteristics, reference 39.

Engine response was an issue in evolving the British Aerospace land-based Hawk aircraft into a USN carrier-based trainer, the T-45 aircraft. Originally flown as the HS1182 prototype, the Hawk first flew in August 1974. The Rolls Royce Adour MK 861 engine had a mechanical fuel control. The USN purchased a Navalized version of the aircraft, renamed the T-45 Goshawk, in November 1981. The modifications required added significant weight to the aircraft and during testing in 1988, the aircraft was found deficient in the CV approach task. Adequate control on the GS and waveoff were cited as deficiencies, references 40 and 41. Extensive modifications to the aircraft, including wing slats and increased engine response were required before the aircraft was accepted for fleet use.

To reflect the importance of aircraft acceleration to thrust response, NAVAIRSYSCOM has adopted two criteria that account for large and small throttle changes. The large throttle response criterion reflects a waveoff type condition where full intermediate power is applied. The small throttle response criterion reflects the small inputs required for GS corrections. Historically, the large throttle criterion came first in the late 1950's timeframe. Following the F-111 program, the small throttle criterion evolved in the late 1960's and was used as an F-14A requirement.

2.6.6.1 Large Throttle Response (Longitudinal Acceleration)

The intent of this criterion is to ensure aircraft waveoff performance. The first time thrust response for jet aircraft was highlighted was in "A Flight Evaluation of the Factors, which Influence the Selection of Landing Approach Speeds," F.J. Drinkwater & G.E. Cooper, NASA Memo 10-6-58A, 1958, reference 11. Reference 11 states, "For the conditions in which engine thrust was used to control the FPA at the minimum comfortable approach speeds, reductions in the margin of thrust-weight ratio (T/W) available for climb at military thrust to less than 0.12g (3.86 ft/sec²) gave unsatisfactory control.... Examination of the data... indicated that the thrust-weight ratio required increased with reductions in airspeed on several of the configurations; hence the pilot could obtain a larger thrust margin by flying at a higher airspeed." Additionally, reference 18 characterized a late waveoff as "extremely demanding on airplane performance because of the descending glide path in proximity to the ship. It is therefore mandatory that optimum approach speeds also be predicted on the ability of the airplane to satisfactorily execute a proper waveoff. The excess thrust available for the proper waveoff should be sufficient to provide an airplane acceleration of 3 knots per second."

The first time thrust response for a jet aircraft was mentioned in a BUAER context was in reference 17, which states: "... Navy experience also indicates that inadequate excess thrust can be a limitation. Specifications of some models require that the ratio of excess thrust-to-weight be at least 0.15 (4.83 ft/sec²) at normal weights and 0.09 at overload weights. It is important, of course, that this excess thrust be obtained rapidly in the event a waveoff is desired...."

In "Comments on the Carrier Suitability of Various Airplanes", NATC Memo FT2211 of May 1966, with respect to the F-111B, reference 42, it was noted regarding engine response for large throttle input, "Rapid acceleration (5 seconds maximum from Idle to Military) should be required at all thrust levels." For waveoff performance, "... Sufficient excess thrust should be available on a hot day to accelerate the aircraft 3 Knots per second (5.06 ft/sec²) at waveoff." Also, "Engine acceleration time from approach power setting to Military thrust should not exceed 3 seconds."

In "BUWEPS Approach Speed Criteria", reference 43, the criterion is stated as, "A longitudinal Acceleration of at least 5.0 ft/sec² on a hot day (90°F) in a level attitude at zero FPA will be available within 2.5 seconds after initiation of throttle movement to the military thrust position while at $V_{pa_{min}}$." The reference 1 definition uses a tropical day condition of 89.8 °F on GS.

Additionally, reference 21 reported the test results of five then current carrier-based aircraft (two fighter and three attack designs). It was stated "Experience has shown that the level flight acceleration capability is a good indicator of waveoff capability. A longitudinal acceleration of at least 5 ft/sec² was determined to be the minimum acceptable value.

2.6.6.2 Small Throttle Response

From reference 19, the small throttle response criterion originated from concerns related to the F-111B thrust response on the GS. Experience with the A-5/RA-5C may have also provided some impetus for this criterion.

Reference 44 contained the following small throttle criterion:

On a 4 deg GS, "To insure rapid thrust response to small thrust changes the following shall be obtained at V_{PAmin} :

$$t_1 < 2.0t_2.$$

where: t_1 = time required from ($T_{stab} - 1,000$ lb to T_{stab})
 t_2 = time required from (T_{stab} to $T_{stab} + 1,000$ lb)
 T_{stab} = Thrust required per engine on a 4 deg GS

The reference 1 form of the criterion was originated in the mid 1970's by Mr. Ralph A'Harrah (Head of NAVAIRSYSCOM FQ), reference 45, to assure adequate aircraft response to small throttle changes. Initially, the 1974 VFAX Type Specification, reference 46, contained the small throttle response criterion as a footnote with a commanded acceleration value of 6.5 ft/sec^2 . A few years later, this value was changed to $\pm 3.86 \text{ ft/sec}^2$ for the F/A-18A specification, reference 47. The draft December 1985 A-6F Detail Specification, reference 48, used 4.0 ft/sec^2 .

2.6.7 WAVEOFF

A waveoff is a frequent occurrence in the shipboard environment and one that may be required due to the landing area becoming "foul" (not being ready to recover aircraft), unacceptable pilot technique, or conditions outside safe recovery parameters, such as excessive deck motion. The original straight-deck CV approach did not place very demanding requirements on aircraft performance in the waveoff. The approach was flown in essentially level flight until the LSO gave the pilot the CUT, and the approach could be aborted at any point by simply not executing the CUT and applying power. Moreover, piston-driven engines respond to throttle changes very quickly.

Modern day approaches are flown to angled decks at constant GS, nominally 3.5 or 4.0 deg in high WOD conditions (above 30 kt). The higher approach speeds of modern jet aircraft resulted in descent rates between 10 and 20 ft/sec during the approach. Therefore, after waveoff initiation, some altitude is lost and distance to touchdown is reduced before a positive rate of climb can be established. The time required to arrest sink rate and begin climbing is increased by the relatively slow acceleration times of turbojet engines, and the even slower acceleration times of turbofan engines.

With the advent of digital FADEC's, engine response for specific programmed inputs can be optimized to provide the desired response without significant tradeoffs in performance in other areas. There are additional waveoff scenarios, like the Case II waveoff (1 ball high, throttle chop to idle until passing through nominal GS, followed by immediate advance to military rated thrust) that may be more critical and more demanding on the engine controls and resulting response.

Prior to the JSF program, the USN had no design specification for waveoff but rather had a flight test validation procedure found in the 1963 version Carrier Suit Testing Manual, reference 49, that states:

“Normally, if the previous tests [referring to CV approach speed and longitudinal acceleration tests] have been exhaustive, the waveoff capability will usually have been defined. The only situation in which waveoff capability can be compromised is in the thrust adjustment case when the excess thrust for maneuvering has to be sacrificed in order to place the engine operation point at higher RPM to improve the thrust response and engine acceleration characteristics for small throttle changes”.

The JSF waveoff performance requirement originated with the JSF Joint Initial Requirements Document in 1996, reference 50, as a Warfighter requirement. The JSF program is the first to require a threshold level of waveoff performance. The requirement was maintained in the JSF JMS, reference 2. Reference 2 used legacy aircraft data from the F/A-18C to establish a maximum allowable amount of sink during a waveoff from a specified GS. This level of performance was based on Warfighter fleet satisfaction of F-18C waveoff capability. The JSSG, reference 1, maintains a separate but similar waveoff criterion.

2.6.8 BOLTER

The concept of a bolter, an unintentional shipboard touch-and-go, did not exist on straight-deck carriers. Once the CUT was given to an approaching aircraft, the aircraft either engaged a cross-deck pendant (CDP), also referred to as a “wire”, or was stopped by a barrier. Failure to arrest could be caused by a long landing or by a hook-skip. The barrier was necessary because personnel and equipment occupied the flight deck forward of the landing area. Engagement of the barrier was undesirable as it normally resulted in structural damage to the aircraft and the barrier itself. This often caused operational delays while the aircraft was cleared and the barrier reset.

With the advent of the angled decks, the area forward of the landing area was cleared and failure to engage a CDP required the aircraft to execute a touch-and-go. CDR R. M. Netherland in reference 29 stated, "The secret to executing a bolter properly is having made all your traps as if you expected to bolt (full power, brakes in) and having practiced careful instrument flying following takeoffs in night mirror landing practice. Acceptance of the bolter is the first step. Except for hook skips, you should be aware when it is about to happen. You have been high/fast. The ball should have told you - if you watched it all the way. Accept it, fly smoothly off the angle, rotate nicely, maintain heading, climb and prepare for another approach under CCA control. Once you are set-up, analyze your errors. Why did you bolt? It's no time for fierce, angry determination to land at all costs; it's a time for cool analysis and firm resolve not to repeat the previous error. Your biggest hindrance is your own anxiety." A bolter at night can be unsettling to a pilot, who will go without warning from an external visual environment to possibly complete blackness in a matter of seconds. The aircraft in the bolter could be near minimum controllable airspeed, and there are only 400-500 ft of flight deck left after the last CDP. It is therefore desirable that the aircraft achieve positive rotation in that distance using a normal piloting technique; and once airborne, the aircraft display acceptable FQ.

CDR Netherland noted another relevant change from straight to angled decks, which was the throttle technique applied. The CUT on a straight-deck carrier was executed by retarding the throttle to idle. The relatively slow acceleration time of jet engines implies that any hesitation in applying power will adversely affect the bolter. Pilots are therefore trained to apply full power on touchdown. If sustained deceleration is felt as a result of the CDP engagement, the pilot retards the throttle to idle.

The desire to become airborne in a relatively short distance means that design criteria such as nosewheel liftoff speed become especially important. Other design elements of little concern to shore-based aircraft become important as well. The dynamics of the landing gear can easily determine whether the aircraft, following touchdown from a landing attitude, has a gear reaction that enhances rotation to takeoff attitude.

Historically (substantiated by Jack Linden, reference 20), prior to the late 1960's, there was not a bolter requirement specified in a contract. However, the following gave program managers reason to believe that the aircraft under consideration would bolter successfully:

- a) The NATC Carrier Suit Testing Manual gave contractors insight how the aircraft would be tested for bolter characteristics.
- b) General wording in aircraft specifications, such as the VFAX in paragraph 1.3.1, reference 46, states that "The aircraft shall be fully operable from CVA-59 and subsequent class carriers." This implies an acceptable bolter.
- c) Guaranteed Performance for minimum usable approach speed and one engine inoperative rate of climb in the approach configuration gave assurance of adequate flyaway capability. Several legacy aircraft had guaranteed takeoff distance with a store-loaded configuration, which helped set the design for rotation rate.
- d) The necessity to do field takeoffs at heavy gross weight with forward CG positions gives assurance that sufficient rotation would be available at lighter carrier landing weights with a more aft CG position.

In general, these assumptions worked for legacy aircraft which normally had little problem meeting the bolter task under both normal and degraded conditions. (The applicability of the assumptions related to takeoff requirements is not reasonable since the landing high lift configuration can differ significantly from the takeoff configuration.)

In the late 1960's, the need to have a more defined bolter requirement led to the development of one which was intended to go in the proposed F-14A Detail Specification, SD-561-1, reference 30. It could not be determined why the requirement was not put in the F-14 Specification. A similar requirement for bolter was put in the F/A-18A Specification (SD-565-1), reference 47, paragraph 3.3.1, which, in effect, added a new requirement to MIL-F-8785C, reference 36. More recently, the challenge of designing an affordable multiservice, next generation strike-fighter weapon system prompted the JSF program to include in their specification, reference 2, ground rules established from the Carrier Suit Testing Manual, reference 51. The main difference between the F-18A and JSF

bolter requirements is the F-18A specified the aircraft rotate prior to leaving the deck where the JSF requires no sink at the pilot design eye position (DEP).

2.7 SUMMARY

A reliable set of metrics to predict Vpa with reasonable accuracy was necessary so loads could be predicted and the structure designed with the appropriate margins. The objective of the early CAC was to predict Vpa for design purposes only – Vpa was still to be defined through pilot evaluation and flight testing. As the CAC evolved through the late 1950's and 1960's, Vpa prediction criteria became "design to" criteria. That is, the approach AOA and resulting Vpa became defined as part of the analytical development. Flight testing was performed to confirm the suitability of the defined Vpa. Discussions with BUAER engineers confirmed that the current application of the CAC (to define Vpa) is not consistent with the intent of early investigators of the CAC development.

THIS PAGE INTENTIONALLY LEFT BLANK

CHAPTER 3: REQUIREMENTS

3.1 GENERAL

With any government system procurement, an acquisition process exists to support development of requirements, concept exploration, research and development, demonstration, and system deployment. The process inherently has many checks and balances that allow for the identification and assessment of risk associated with system development cost, schedule, or system performance. Risk identification is a critical element of the acquisition process. It is early risk identification that provides the best opportunity for correcting any potential deficiencies before they become too costly, result in a significant program delay, and/or result in shortfalls in system performance.

The basis for a successful system acquisition, in part, is a sound and specific set of requirements. It can be argued that the most critical point in any program is the requirements development phase. Careful balancing of a variety of requirements can easily lead to system requirements that cannot be afforded by the procuring activity. In recent years, several Acquisition Reform initiatives have been instituted by the Department of Defense (DoD) that allow requirements to be balanced against cost. The Cost-as-an-Independent-Variable process enables the requirement developers to balance system performance against system cost although the relationship between the specific requirements and cost are not always apparent. Acquisition Reform permits latitude in requirements development to arrive at the most affordable solution while meeting the needs of the Warfighter. This process is iterative but once the requirements are defined, they serve as the standards by which the system will be designed, developed, tested, and defended throughout the program life. Performance-based specifications are another attempt to provide the designer with maximum flexibility while specifying only mission critical requirements.

Based on the vital role that the acquisition system plays in military aircraft development programs, it is necessary to discuss the acquisition system to define the roles and responsibilities of the various parties involved. Presenting the roles and responsibilities allows for explanation of how the CAC are used in an actual program development scenario and highlight the various uses of the criteria.

3.2 ROLES AND RESPONSIBILITIES

3.2.1 GOVERNMENT ROLES

3.2.1.1 Requirements Generation

The acquisition of a system to provide significant capability to the Warfighter starts with the Mission Need Statement (MNS). The MNS identifies and describes the projected mission needs of the user in the context of the threat to be countered. The user representative, with support from the operational test and evaluation community, converts the needs expressed in the MNS into requirements usually contained in the Operational Requirements Document (ORD). The appropriate requirements authority shall validate all MNS's and ORD's. In the process of refining requirements, the user shall adhere to the following key concepts as described in DoD Instruction 5000.2, reference 52:

- a) Keep all reasonable options open and facilitate cost, schedule, and performance trades throughout the acquisition process.
- b) Avoid early commitments to system-specific solutions, including those that inhibit future insertion of new technology and commercial or nondevelopmental items.
- c) Define requirements in broad operational capability terms.
- d) Develop time-phased requirements with associated objectives and thresholds (as appropriate).
- e) Evaluate how the desired performance requirements could reasonably be modified to facilitate the potential use of commercial or nondevelopmental items and components.
- f) Evaluate whether system will be able to survive and operate through the anticipated threat environment.
- g) Consider Critical Information Program Information needs, antitamper, and intelligence support requirements.
- h) Address cost in the ORD, in terms of a threshold and objective.

The ORD is the primary development program management document in the Office of the Secretary of Defense (OSD). It summarizes the essential operational requirements that OSD must consider in arriving at a production decision. It is prepared by the Service(s) and coordinated among all relevant parties in the Services and OSD by the Defense Acquisition Executive.

The ORD, when approved by OSD, will identify the limits and conditions by which the program must execute. It will also identify key program characteristics and the expected achievement. These thresholds have been defined in terms of cost, schedule, and performance and cannot be changed or violated without OSD approval. Key Performance Parameters (KPP), a subset of ORD requirements, represent those capabilities or characteristics so significant that failure to meet the threshold value of performance can be cause for the concept or system selected to be reevaluated or the program to be reassessed or terminated, reference 53. Since the Program Manager (PMA for Naval aviation programs) will be the first to know that these limits may be exceeded, the PMA must assume a special burden to be sure that the Service authority is informed of all the pertinent facts and projected results.

The Warfighter defines the system performance thresholds that are in the ORD. The Warfighter is represented by the Operational Advisory Group that works closely with the Requirements Officer (RO), the program leadership, and both the USN and industry engineering disciplines. Figure 9 illustrates these interfaces.

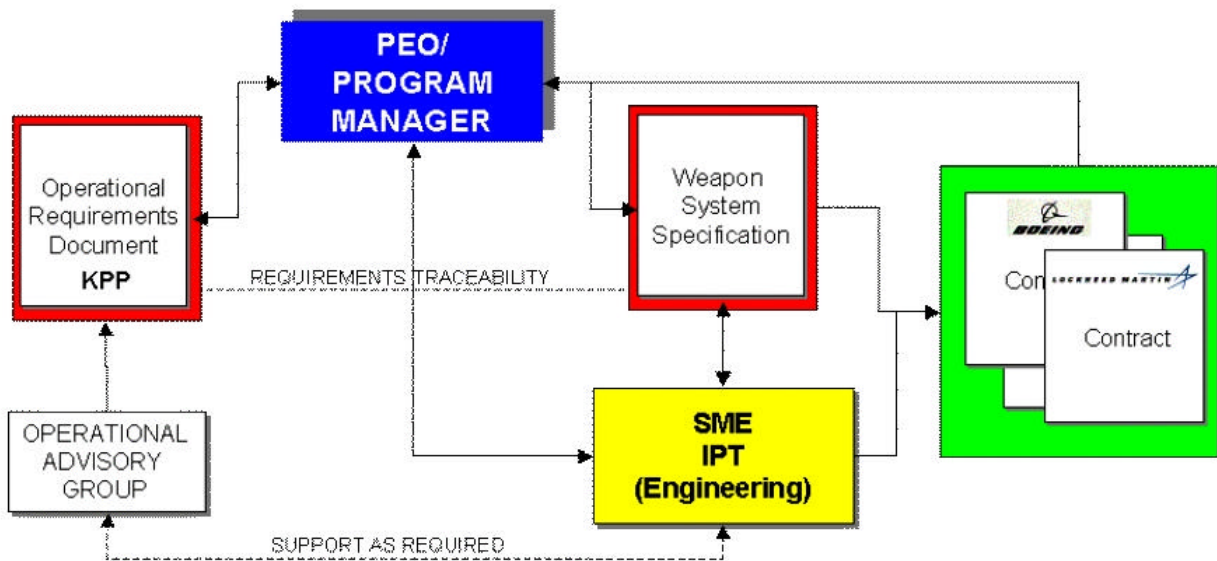

Figure 9: Requirements Process

A second set of requirements are those that are contained within the Weapon System Specification (WSS or detail specification) which is contained within the weapon system contract. The weapon system contract requires more definitive language than that provided in the ORD. The Air Vehicle Department of NAVAIRSYSCOM is responsible for defining airframe performance-based ground-rules for the WSS. The WSS is agreed to by the contractor and contains system requirements and guarantees that must be both measured and demonstrated. For CV suitable aircraft, Vpa has been historically one of the most significant requirements to the Warfighter and is, therefore, typically contained in the WSS. The Air Vehicle Department defines the ground rules for the prediction of Vpa and are published through reference 1. Because of the significance that is placed on Vpa by the Warfighters, Vpa has been routinely identified as a KPP.

There is a close correlation between the ORD and the WSS. In fact, there must be a direct chain of traceability between the ORD and the WSS. The WSS can contain other requirements not specifically defined within the ORD. However, the WSS must have traceability of all the ORD requirements. Since the WSS is derived primarily from the ORD, it is critical that the operational requirements are carefully constructed and defined. Failure of the ORD to adequately define requirements will result in potentially higher cost solutions and undesired performance. Only contract requirements are binding and contract compliance will be determined relative to the contract. However, the operators will evaluate the aircraft relative to the ORD requirements, particularly KPP's.

3.2.1.2 Risk Management

The PMA is responsible to manage the procurement through risk identification and mitigation. Identification of risk is a difficult task requiring Subject Matter Experts (SME's) and Integrated Product Teams (IPT) working closely with industry. The IPT's and SME's aid the PMA in

identifying risk to ensure that the contractual and Warfighter requirements will be met within cost and schedule constraints.

The role of government engineering is to provide the PMA technical expertise in a variety of subject areas. Their primary role is to aid the PMA in the early identification of risk and assist in developing risk mitigation plans. Additional engineering responsibilities include assessment of design methods and processes, review and participation in development test activities, and general counsel of technical issues and program execution. To obtain an early assessment of program risk, it is necessary to determine and assess the requirements that are to be met by the program. The most critical of these requirements are the KPP's. Ideally, requirements assessment should be conducted during the requirements development process.

The CAC, as expressed in reference 1, are used to assess the risk of a design to meet any Vpa, bolter, or waveoff requirement. The CAC also provide a method for ORD tracking and contract compliance prior to flight test. Therefore, the CAC results are used not only as a design tool but also as a standard by which Vpa, waveoff, and bolter performance can be assessed throughout a program. Without the CAC, the challenge to adequately and credibly identify and assess the risk associated with an aircraft design in the approach environment becomes significantly more difficult.

3.2.2 INDUSTRY ROLES

3.2.2.1 Value

A primary role of industry in the acquisition process is to work with government to provide a cost-effective aircraft design that meets well-understood USN requirements. Designing aircraft to operate effectively in the low-speed CV approach environment imposes requirements on wing design, excess thrust, and structural load capability that often conflict with other mission requirements and constrain the design trade space. For example, a highly swept, low aspect ratio wing suitable for high-speed flight or low observability is not consistent with the demands of the low-speed CV approach task which could be more easily achieved with a low sweep, high aspect ratio wing. As a balance is sought between CV approach and other mission requirements, costs will likely increase. Affordability constraints necessitate that industry work in concert with the USN to ensure that all requirements are in tune with current design and manufacturing technology to arrive at a well-balanced, cost-effective air vehicle weapon system.

To ensure the best product, industry and government must have a clear understanding of the Warfighter's requirements and objectives. Similarly, they need to understand the sensitivity of the requirements to acquisition and life cycle costs. Development risks also need to be well understood by all parties. Therefore, it is important that the customer be involved early in the design cycle before the configuration matures to ensure that requirements are in line with expected risks and costs. As the configuration matures, it becomes more costly to modify and accommodate changes in requirements. For example, approach AOA is pivotal to carrier-based aircraft design. Requirements for CV approach high-lift characteristics and the approach AOA need to be set early in the design and should not change.

Industry and government also need to mutually understand what, if any, margins have been incorporated in the customer's requirements or the contractor's design to accommodate development risk. These margins may reflect design, manufacturing or process uncertainties that may no longer exist or are already factored into the design. While industry is striving to eliminate these uncertainties to improve marketability of their products and obtain a competitive advantage, government has historically tended to include margins as a hedge against configuration development growth. And recently, affordability constraints have driven increased use of joint service programs, placing further emphasis on understanding design and requirements drivers. The improved affordability of joint service programs is achieved through commonality. Commonality puts further pressure on the allowable design space afforded to carrier-based aircraft, requiring the impact of all service-unique requirements be fully understood and minimized.

3.2.2.2 Design Process

Carrier-based aircraft must meet all operational Warfighter requirements while maintaining excellent low speed FQ and handling characteristics for CV operations. CVS extends to nearly every aspect of the aircraft design, and must be addressed from design inception in order to obtain an acceptable configuration for the CV environment. To accomplish this, CVS requirements must be central to each stage of the design process. General guidelines covering every aspect of CVS have been developed using Military specifications and extensive USN and industry experience. Figure 10 depicts some of the many design constraints that are used as a starting point for establishing a CV suitable design in the preconceptual design stage. A good understanding of the mechanics of each of the design areas is paramount to meeting all the CVS requirements. Often a change in one area will affect the design of the aircraft in a much broader manner than expected. Consequently, the requirements need to be well understood and well matched to obtain the desired system performance.

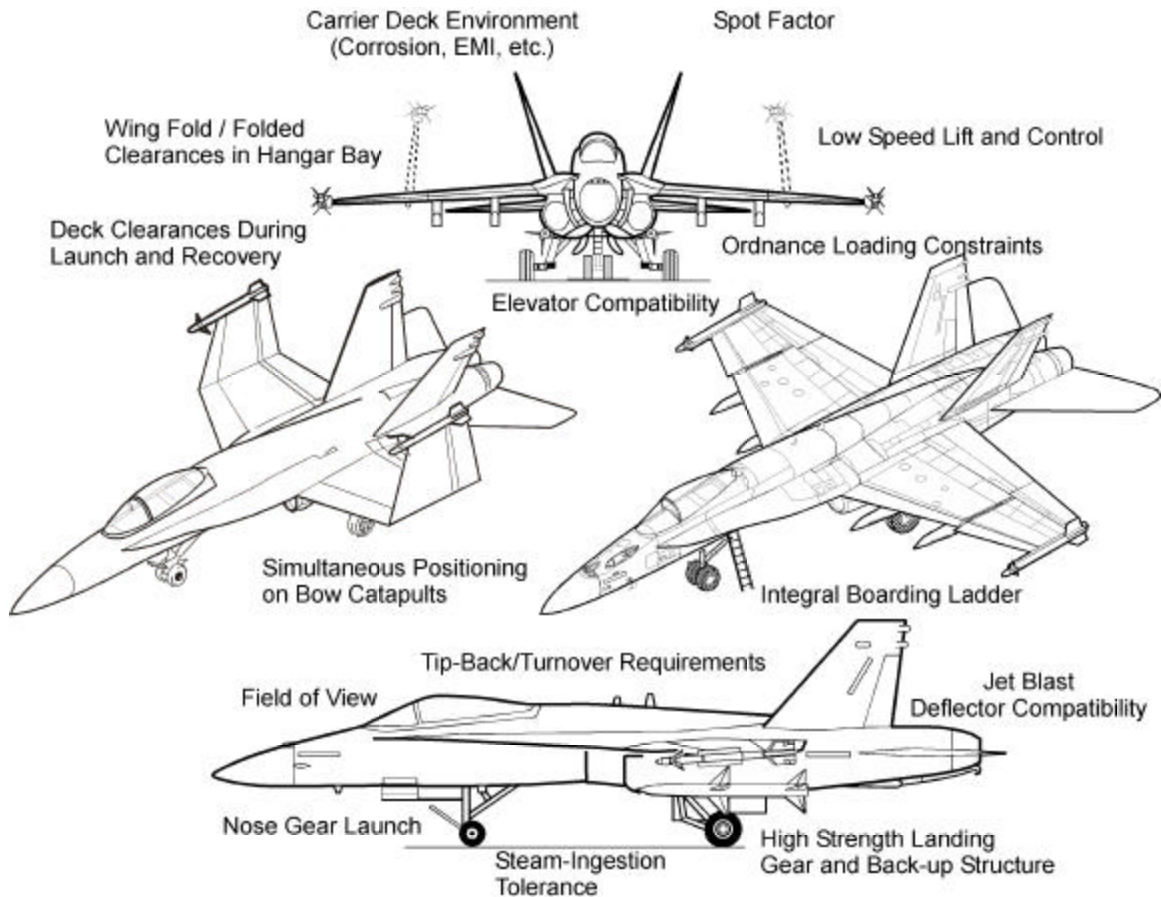

Figure 10: CVS Design Constraints

Because Naval aircraft are usually designed in competition between two or more contractors with each having one or more design concepts, it becomes extremely difficult from a competitive view point for a contractor to fail to satisfy any requirements, particularly a Vpa requirement. Even though the design may exhibit exceptional CV approach characteristics through reasonably high fidelity simulation, failure to satisfy the CAC for Vpa prediction is a risk that the leadership of the design team generally will not allow. Therefore, the criteria, although not specifically defined as requirements, in practice become “hard requirements” to the design team.

At design inception, a rigorous evaluation of each design area is performed to ensure that the design space for the aircraft includes all areas of CVS. Trade studies are initiated to address deficiencies or assess design margins. As the program and design progress, these trade studies are narrowed and focused to address specific customer needs and requirements, to find the best-balanced design solution. To accomplish this, the design process must focus on CVS requirements at each stage of the design and development process, with extensive testing and simulation used to validate all carrier suitable designs.

In the preconceptual design phase, extensive trade studies are used to define an aircraft design space, which would satisfy all performance criteria (figure 11). Positioning the aircraft in the available

design space is critical in the early stages of the design. This allows for a design that is evolutionary in nature rather than one that changes from point design to point design.

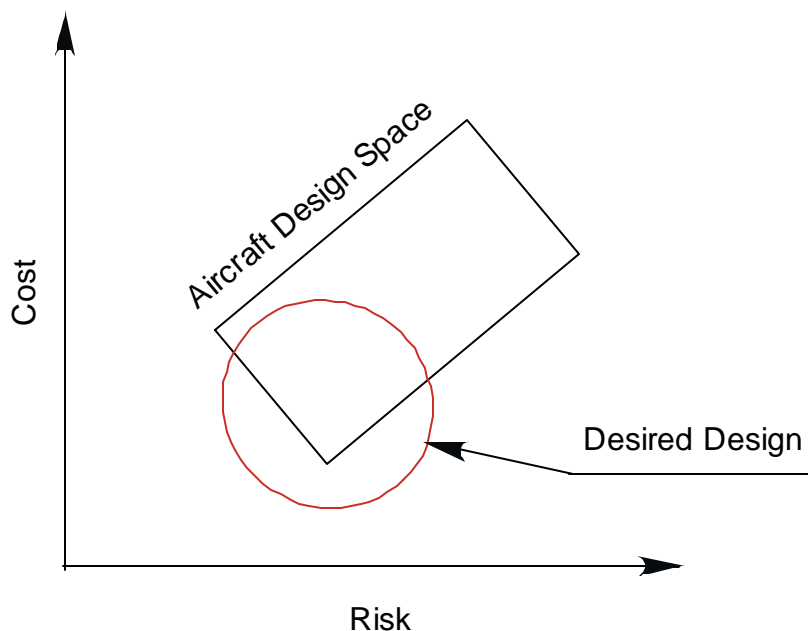

Figure 11: Design Space

The impacts of the CAC definition of V_{pa} ripple throughout the design of carrier-based aircraft. Numerous design trades are required to ensure a well-integrated and balanced design that offers an affordable solution to overall mission requirements. Examples include wing/tail/body integration, canopy/forebody integration, wing/body/landing-gear integration and integration of control system actuation and hydraulic requirements. Since these design trades affect major long-lead procurement items such as engine(s), landing gear, airframe, and various subsystem hardware and software elements, it is imperative that these criteria realistically reflect CV approach requirements.

3.3 CARRIER APPROACH CRITERIA INCONSISTENCIES

The previous sections present how the CAC are used by government and industry to ensure that the needs of the Warfighter are met. The government uses the CAC to predict and assess V_{pa} . The ability to make predictions early in the program allows for risk identification and assessment. Industry relies on the CAC to conduct cost and design trades that define the design space from which a design can meet the stated requirements. It is also known that there are operationally deployed carrier-based aircraft that, at their design, V_{pa} violate some of the current CAC. This apparent contradiction has concerned some in government and frustrated industry in their design process, resulting in criticism of the current CAC. This criticism is amplified when, during joint development programs, service-unique requirements are to be minimized to maintain the greatest opportunity for commonality and reduced cost. The designer's view questions the need to meet criteria with their design that appear not to impede the capability of currently deployed aircraft from meeting the challenge of the approach task. And if the designer still is required to meet these criteria, are then the criteria asking for more capability than is required leading to an overspecified

requirement. The potential outcome of an overspecified requirement is higher costs incurred by the PMA and the Warfighter due to the addition of unnecessary capability incorporated without significant improvement in operational capability. This criticism is balanced by the realization that, while some aircraft may not satisfy all of the current CAC, Naval aircraft for the past 40 years have been designed against an evolving version of the CAC and have resulted in a fleet of carrier suitable aircraft.

It is important to note that the debate between industry and government is not over the need for CAC. In fact, through the efforts of developing this report, industry and government agree there must be a set of CAC to aid the government as well as the designer. The question faced by government and industry is: What should the criteria be? In team discussions leading up to this report, it was concluded that if all of the requirements and accompanying criteria have a sound technical basis, there would be less debate over the criteria definition and more constructive interchange over design solutions. All parties benefit if the requirements do not imbed criteria which add significant penalties and risk to the design. Government and industry also agree that the improved definition of the CAC requires continued involvement of both parties. This investigation has revealed that a process for more frequent discussions on the topic to ensure CAC currency and relevance is required. Therefore, it is recommended that NAVAIRSYSCOM define a process for periodic review and assessment of the CAC that includes both government and industry representatives.

CHAPTER 4: NAVAL AIRCRAFT DESIGN CHALLENGE

4.1 GENERAL

The designer of carrier-based aircraft must address not only the mission requirements shared by land-based aircraft, but must design for the aircraft-ship interface. These requirements include not only the launch and recovery of the aircraft but also the integration of the aircraft within the limited space of a flight deck. The CV approach consideration must be balanced with all other pertinent CV interface requirements. To achieve a balanced solution, the designer must have in-depth knowledge and experience with the systems and the environment for which the aircraft is to operate. The Naval aircraft design challenge is the balancing of these requirements to achieve an effective weapon system that meets all requirements.

The following sections provide background information on the CV approach environment, design process, and key aircraft attributes that influence Vpa. For the approach phase, it is necessary to develop the key parameters and definitions that are affected by determination of Vpa. This review allows for the design considerations of the aircraft as well as the CV. From this basic understanding, a discussion of the design process is presented to provide additional detail of key aircraft attributes. To properly address the design process, background from a pilot and LSO perspective is also provided to aid in presenting the considerations that a designer must address.

4.2 AIRCRAFT CARRIER ENVIRONMENT

This section describes the physical equipment aboard current fleet carriers germane to the landing task. Understanding the capabilities and limitations of this equipment provides the foundation for many of the constraints imposed on the landing problem discussed subsequent to this section.

4.2.1 FLIGHT DECK CONFIGURATION

A detailed layout of NIMITZ class aircraft carriers is presented in the Aircraft Carrier Reference Manual, reference 54. Reference 54 provides the standard flight deck markings including details of the landing area ladder lines and safe parking lines. Additional details of the visual landing aids (VLA's) are presented in the VLA's General Service Bulletin, reference 55.

4.2.2 ARRESTING GEAR SYSTEMS

4.2.2.1 General Description

The arresting system consists of a hydraulic piston/ram energy absorber that supports a purchase cable coupled to a CDP. Service life upgrades are regularly incorporated into the shipboard system. Service Change (SC) 428, introduced into the fleet in 2000, extends service life by incorporating higher strength purchase cables, CDP's, and other service life related items. The operating characteristics of the two systems are presented in table 3. Detailed discussions of the operation and control of the arresting gear system are presented in reference 54.

Table 3: Arresting Systems Characteristics

		MK 7 Mod 3	MK 7 Mod 3 with Service Change 428
Limitations	Maximum Energy Absorption at Service Stroke (ft-lb)	43.5 x 10 ⁶	43.5 x 10 ⁶
	Maximum Allowable Cylinder Pressure (psi)	10,000	10,000
Engine	Two-Blocking Stroke (ft)	195	195
	Constant Runout Service Stroke (ft)	183	183
Cables	Purchase Cable	Diameter (in.)	1-7/16
		Rope Lay	6 x 25
		Breaking Strength (lb)	195,000
	Cross-Deck Pendant	Diameter (in.)	1-3/8
		Rope Lay	6 x 30
		Breaking Strength (lb)	188,000
Service Runout	Deck Pendants (ft)	340	340
	Barricades (ft)	388	388

4.2.2.2 Performance Capabilities

The arresting gear performance capabilities and influence on shipboard operations are presented due to the relationship between V_{pa} , arresting gear limitations, and resulting recovery WOD requirements. Performance charts for the MK 7 Mod 3 are presented in figure 12 obtained from reference 54.

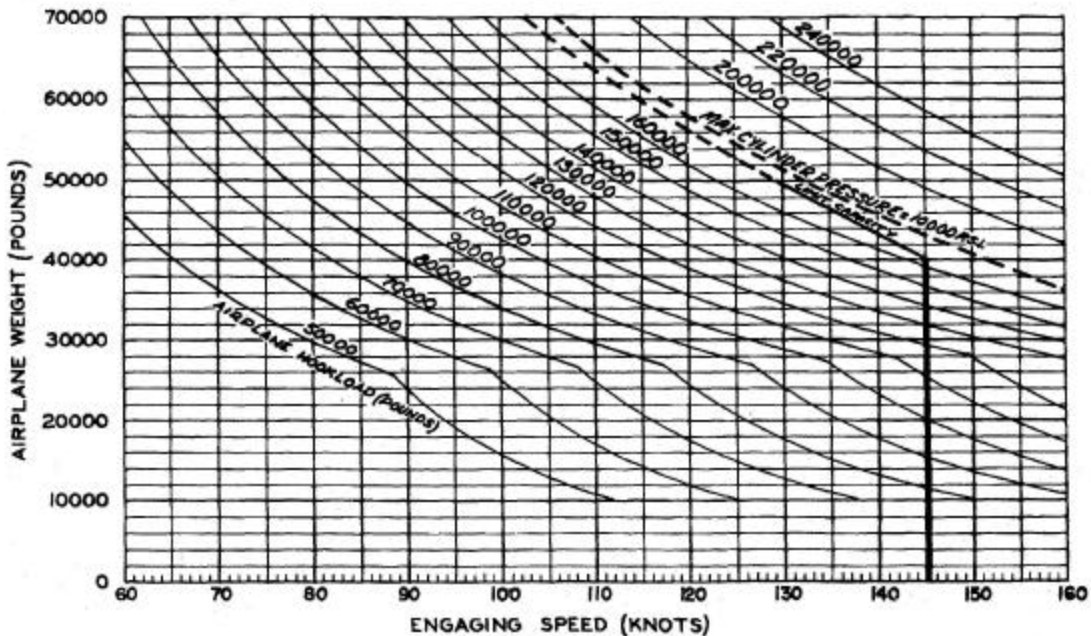

Figure 12: MK 7 Mod 3 Arresting Gear Performance

Figure 12 presents the relationship between aircraft GW and arresting gear engaging speed shown as a family of curves presenting aircraft arresting hook axial load. Limit capacity for aircraft GW's above 40,000 lb is based on cable strength, whereas below 40,000 lb is based on cable impact speed which is limited for the MK 7 Mod 3 arresting gear to 145 kt.

As deduced from figure 12, engaging speed is sensitive to weight. The limit engaging speeds (closure rates) into the arresting gear dictate the Recovery Head Wind (RHW) which is defined as the difference between the aircraft's true airspeed and the arresting gear capacity. For GW's below 40,000 lb, the increase in RHW is equal to the increase in airspeed, i.e., for each knot increase in V_{pa} , the RHW must be increased 1 kt to retain the same limit arresting gear engaging speed. However, for aircraft GW's above 40,000 lb, an additional penalty is incurred. Not only does V_{pa} increase due to the higher GW, but the limit arresting gear engaging speed must decrease to remain within arresting gear capacity. For current carrier-based tactical jets, this combined penalty is approximately $3\frac{1}{2}$ kt of increased RHW for each 1,000 lb weight increase. It is important to note that at these higher recovery weight conditions requiring the engaging speed to be lowered, the actual closure speed is also lowered.

4.2.3 AIRCRAFT RECOVERY BULLETINS

Aircraft Recovery Bulletins (ARB's) are the documents that define shipboard recovery requirements for aircraft. The Fleet operator uses the ARB's to set the appropriate weight settings for the arresting gear engines and define the RHW requirements for landing. Two ARB's are published for each arresting gear type, references 56 and 57 for MK 7 Mod 3, and references 58 and 59 for MK 7 Mod 3 with SC 428. The first reference for each type of arresting engine provides instructions concerning

recovery of aircraft, while the second reference contains the aircraft recovery data used in the preparation of the ARB. Two other ARB's are of interest; reference 60 contains general information on the preparation and use of the ARB's above and reference 61 governs the MK 6 Mod 3 Fresnel Lens Optical Landing System (FLOLS).

The following relevant notes are extracted from ARB's referenced above:

- a) The aircraft's touchdown airspeed specified is 105% of the approach speed value determined during flight tests at the recommended approach AOA. The speed in the ARB is a landing speed based on the results of statistical analysis of measured landing speeds aboard ship. This landing speed is higher than that determined during flight tests to account for variables in aircraft pitot-static systems, AOA and high lift systems, turbulence, errors in shipboard anemometer systems, and ground effect.
- b) The RHW data presented is based on Standard Sea Level Day conditions of 59°F temperature and 29.92 in. Hg barometric pressure. RHW compensation is provided for temperatures above 59°F. There is no compensation for barometric pressure.

When operating conditions permit, it is common Fleet practice to increase RHW by 6 kt to improve safety margins.

4.2.4 FRESNEL LENS OPTICAL LANDING SYSTEM

4.2.4.1 General Description

Characteristics of the MK 6 Mod 3 FLOLS are summarized in the following paragraphs and described in detail in the NATOPS LSO Manual, reference 62. The shipboard FLOLS is an electro-optical VLA used to provide the pilot with a visual indication of GS position relative to a predetermined GS. This GS provides for arresting hook touchdown within the arresting gear layout. Physically, the FLOLS consists of an indicator assembly, pitch and roll stabilization drive assemblies, datum lights, waveoff lights, emergency backup waveoff lights, and "cut" lights. A bar of yellow light is displayed over the width of the indicator assembly, and when viewed at the prescribed GS position, this bar of light, also called the "meatball" will be aligned with green datum lights. When the pilot is above the prescribed GS, the "meatball" will appear above the datum lights. Conversely, the pilot will see a low "meatball" when below the prescribed GS. Figure 13 illustrates the FLOLS configuration.

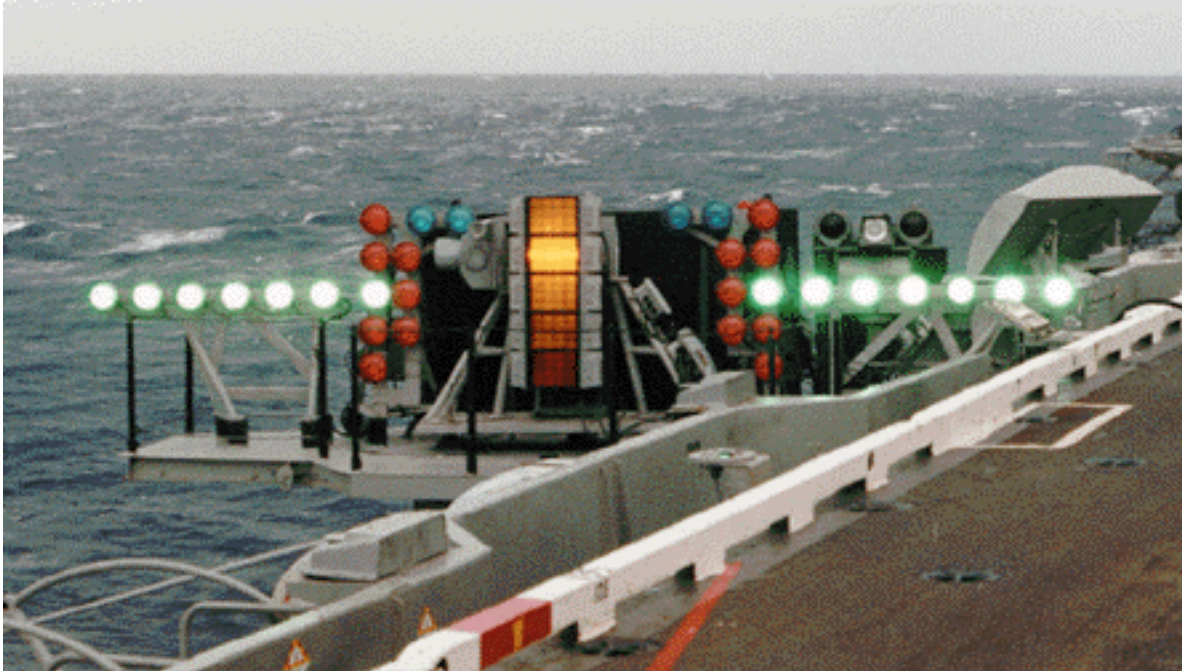

Figure 13: FLOLS

For NIMITZ class ships (CVN-68 through CVN-75), the FLOLS unit is located at flight deck level, 486 ft forward of the stern. The targeted arresting hook touchdown point is midway between the second and third arresting gear, approximately 230 ft forward of the ramp. Using a reference FLOLS roll angle of 7.5 units and a GS of 3.5 deg, a hook-to-ramp (H/R) clearance of 14.1 ft with a vertical hook-to-eye (H/E) distance of 15.4 ft is provided. A detailed discussion and calculation of the H/E is presented in Section 6 of reference 51. The vertical FOV of the indicator assembly is 1.7 deg provided by five Fresnel cells, each providing 0.34 deg of angular coverage. The focal point of the cells is 140 ft forward of the FLOLS assembly. This provides for a vertical FOV of the FLOLS as described in table 4.

Table 4: FLOLS FOV

Distance from Touchdown	Vertical Beam Height of Any Cell (ft)	Vertical Beam Height of All Five Cells (ft)
0	2.4	11.8
230 ft (ramp)	3.7	18.6
¼ nm	11.3	56.3
½ nm	20.2	100.8
¾ nm	29.1	145.3
1 nm	38	189.8

Because of the differing physical geometries of carrier-based aircraft (specifically the H/E distance), the optical system must accommodate each aircraft model to set a consistent targeted hook touchdown point on the flight deck. As previously stated, the reference FLOLS roll angle of 7.5

units accommodates a H/E distance of 15.4 ft. To accommodate aircraft with a different H/E, the FLOLS roll angle can be changed to provide the pilot indication of proper GS position while maintaining the proper arresting hook point path and touchdown position. A 1 unit (degree) change in the FLOLS roll angle equates to 1.5 ft vertical displacement in the on-glide slope position when on the centerline of the landing area.

4.2.4.2 Stabilization

FLOLS stabilization is provided from signals from the ship's stable element to provide a stabilized GS with respect to the horizon, under moving deck conditions. Two modes of stabilization are available:

- a) Line Stabilization: Used as a backup, this mode stabilizes the FLOLS display for pitch and roll motions of the ship to maintain a predetermined line in space at the intersection of the FLOLS light plane and the true vertical plane through the centerline of the angled deck. This stabilizes GS without compensation for ship's heave.
- b) Inertial Stabilization: The inertial stabilization mode is the primary mode of operation for the FLOLS. This mode adds compensation for ship's heave to the line stabilization.

4.2.5 IMPROVED FRESNEL LENS OPTICAL LANDING SYSTEM

The MK 13 Mod 0 Improved FLOLS (IFLOLS) is the system replacement for the shipboard MK 6 Mod 3 FLOLS. IFLOLS provides more precise GS information and its improved optics have a greater range than that provided by the FLOLS. Details of the IFLOLS are documented in Theory of Operation, IFLOLS, reference 63.

4.2.5.1 Drop Lights

The drop light unit is a VLA that provides medium range (approximately 1 ½ nm) lateral lineup information to the pilot. The assembly consists of a vertical bar of lights at the stern of the ship that starts just below the flight deck round-down. For NIMITZ class CV, depending on the ship, the vertical bar contains 11 or 13 red lights, spaced at 39-in. increments. Pilot perceived off-center information obtained from the drop lights and the flight deck lighting is presented in figure 14.

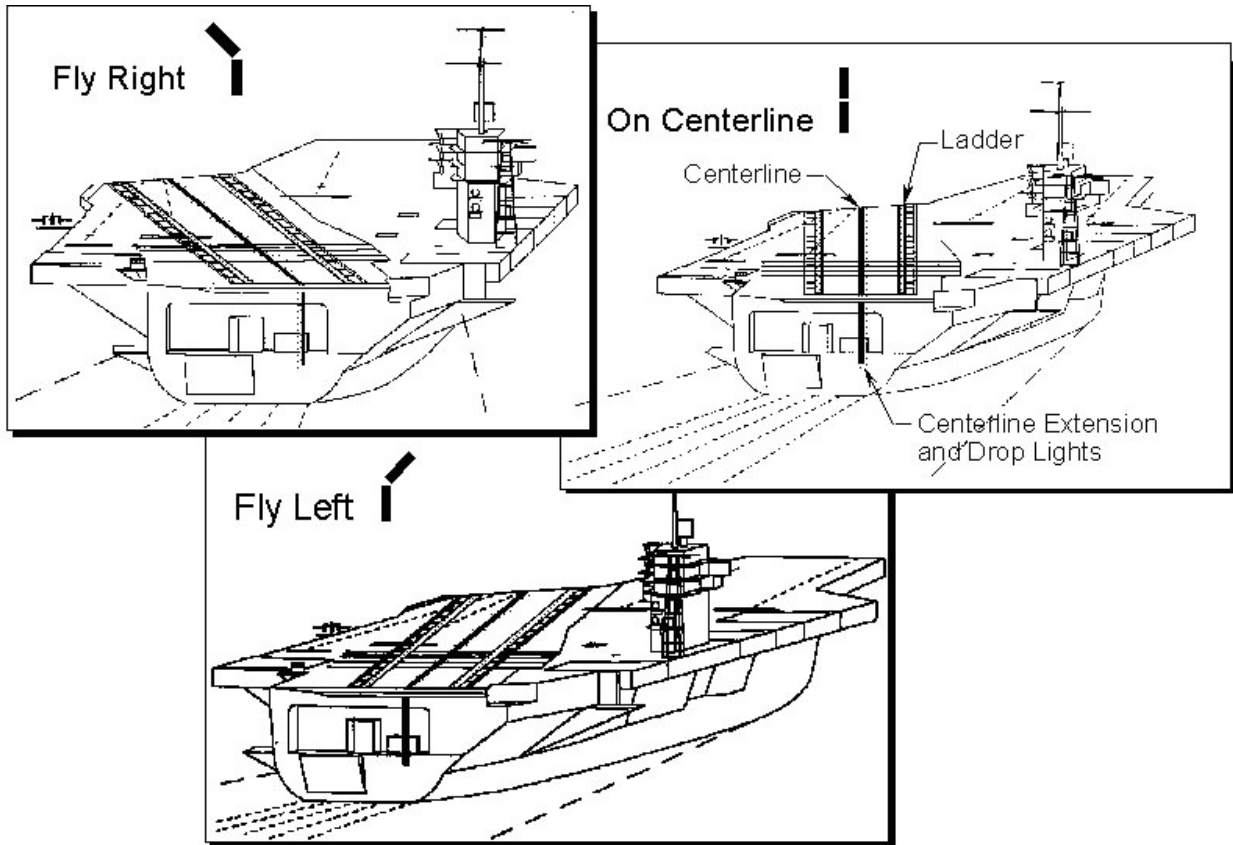

Figure 14: Drop Light and Flight Deck Lighting Indications

4.2.6 AUTOMATIC CARRIER LANDING SYSTEM

The Automatic Carrier Landing System (ACLS) has been a feature of carrier-based aircraft since the 1960's providing the capability for automatic hands-off landing. The shipboard based AN/SPN-46 ACLS consists of a precision tracking radar, general purpose computer, and data link transmitter, and is designed to automatically control an ACLS equipped aircraft to touchdown when operating in its most automated mode, known as Mode I. Radar tracking of a beacon system in the aircraft establishes aircraft position. Computer software, containing the necessary control logic, generates aircraft vertical rate (or pitch) and bank angle commands to direct the aircraft along the desired glide path. Commands are sent to the aircraft via a UHF data link.

The ACLS provides for three primary modes of operation that can be selected by the pilot. The first is the Mode I approach which provides for fully automatic approach from ACLS lock-on to touchdown on the CV deck. The approach can be downgraded to a manual approach at 1/2 nmi to touchdown. In this case, it is referred to as a Mode IA. The second is a Mode II approach where the pilot manually controls the aircraft using ACLS error signal guidance provided on the cockpit displays. The third is a Mode III, or Carrier Controlled Approach (CCA), where the shipboard controller talks the pilot down using ACLS provided position information relative to the ideal GS. The use of an autothrottle is required for Mode I/IA, but it is optional for a Mode II or a Mode III approach. The utilization rate of ACLS in the Fleet varies from squadron to squadron. A more

detailed description of the ACLS can be found in the Carrier Suitability Testing Manual, reference 51.

Significant to this study, ACLS does not place additional burden on the designer for Vpa. If an aircraft has adequate control power and GS control for manual landings, satisfying the CAC for that task, then the design is typically adequate for ACLS. ACLS Mode I performance, however, must be taken in the context of the total system, including the aircraft and the shipboard equipment. Any change affecting the CV approach performance of the aircraft will likely require a reoptimization of the ACLS and/or aircraft autopilot control laws to achieve overall satisfactory performance of the system.

4.2.7 APPROACH AND LANDING PATTERNS

Full discussion of the CV approach and landing patterns may be found in the CV NATOPS, reference 31. Generally, there are two patterns flown by fixed-wing aircraft on approach to the ship. The Case I pattern applies to day, visual flight rule conditions, while the Case III pattern applies to either night or instrument conditions. Variations exist (EMCON and Case II) that combine elements of the Case I and III patterns. Both Case I and Case III are intended to provide a start to final approach with the aircraft, on-speed and established on GS and final bearing. The paths to this point differs between Case I and Case III, but from ½ mile to touch-down, the trajectories are identical. Implications of the two patterns will be developed in Section 4.5.

4.3 THE CARRIER LANDING

The task of landing aircraft at sea on the pitching decks of CV's has long been recognized as being among the most difficult of aviation's tasks. The environment is certainly among the most demanding encountered anywhere. Advances in technology, reflected in the engines, airframes, control systems, and displays have transformed the hazards. The operational challenge for the technologist is to further improve the safety of landing at sea while increasing the likelihood of successful arrestment on the first attempt.

Designing for CVS entails far more than merely landing on a small dynamic runway at sea. It includes design provisions for launch, deck handling, servicing, supportability, maintenance, ordnance handling, electromagnetic compatibility, etc. The scope of this report limits the discussion to those elements that bear directly on the landing problem. References 51, 54, and 64 provide extensive discussions of CVS requirements.

Several engineering constraints dominate the landing problem. The aircraft must land: 1) in the desired spot in order to engage a CDP, 2) with no lateral drift to stay within the landing area during the run-out, 3) in the proper attitude to set the hook properly in the wires, 4) at an appropriate speed so as to not overstress the arresting gear engine, and 5) within the sink rate limitations of the landing gear. Additionally, the LSO wants to see the aircraft cross the fantail of the ship with a specified margin above the round-down to confidently avoid hitting the ramp ("H/R clearance"). Finally, the combination of flight condition and power response has to be such that full power can be rapidly achieved for successful waveoff or bolter. Each of these will briefly be discussed in turn.

CV's have four arresting gear engines, each with one exposed CDP, which is held approximately 4 in. off the deck by a series of leaf springs. These four wires, numbered 1-4 from the aft-most forward are evenly spaced at approximately 20 ft intervals (some ship-to-ship variation exists). The ideal landing spot is mid-way between the second and third wire. Pilots landing short of the first wire receive their due scolding from the LSO's, while those landing beyond the fourth wire add power and initiate another lap of the landing pattern.

It is not enough that an aircraft land close to the centerline of landing area; it is also crucial that each aircraft track closely to the centerline stripe throughout either landing rollout, or bolter. With flight deck space a premium, aircraft are parked literally to within 2-3 in. of the edge of the landing area. Any wingtip excursion, however slight, over the foul-line marking the edge of the landing area, will inevitably contact and damage another aircraft. Drift during a bolter is the more serious of the two in that the pull of the arresting gear does have a centering effect on an arresting aircraft, as well as reducing the likely velocity at the moment of collision. Though lacking the dramatic character of accidents due to GS errors and typically resulting in only Category B or C mishaps, foul-line excursions are the most common of embarked accidents. Long wingspan aircraft are clearly the most frequent culprits, most notably the F-14, which suffered from very poor lateral-directional FQ before the incorporation of a Digital Flight Control System. The pilot has no directional control during the rollout, accepting whatever trajectory has been determined by momentum and the arresting gear forces. Safe landing therefore requires that the touchdown be both precise in lateral location, and absent any significant lateral drift.

Hook touchdown amidst the wires does not guarantee successful arrestment. Although the hook is heavy, the violence of impacting the deck at such speeds can cause the hook to bounce off of the deck and over any wires. Hydraulic or pneumatic actuators or dampers may resist this phenomenon, but the aircraft must still be close to the appropriate touchdown attitude for them to be effective. "Hook-skip bolters" commonly result from a last-second nose-down correction intended to save an "over-powered at the ramp" condition. This "play" for the deck succeeds in guiding the aircraft into the wires, but lowers the attitude such that inadequate pressure is applied to the hook-point to keep it low to the deck.

The arresting gear engines constitute the principal upper bound on V_{pa} . Each arresting gear model and shipboard installation provides a finite capability for absorbing the energy of the arrestment as described in the preceding section. Importantly, it is the kinetic energy expressed by the closure or relative speed that is important. WOD is the vector addition of the natural wind, and the ship's forward velocity. The WOD is commonly between 25 and 30 kt, thereby significantly lowering the closure rate an equal amount. This represents a substantial decrease from the kinetic energy of the aircraft in the inertial reference frame. For the design problem, a WOD requirement when matched with a specified design arresting engine establishes the limit closure energy acceptable. Once V_{pa} is fixed for a design, and a design weight specified, the only variable for operational adjustment is the ship's speed. For emergency landings requiring higher speeds, such as flap malfunctions, the aircraft must reduce its weight, and the ship accelerate to lower the closure kinetic energy to within the arresting gear's limits. There are typically no design requirements for such situations.

Each design must size the landing gear and hook backup structure to accommodate the full range of likely dynamic loads. The design limit significantly exceeds the loads induced by a nominal landing

due to dispersion caused by both sink-rate errors and deck motion. These loads heavily depend upon the landing trajectory. The present trajectory limits the dispersion that might be experienced with other candidate trajectories (such as the "cut-pass" approach of the straight-deck carriers). Once designed, both fatigue and strength limits compel minimization of the landing loads dispersion about the nominal approach.

The LSO bears the responsibility for ensuring the safe recovery of each aircraft. Ramp-strikes and foul-line excursions pose the two principal hazards against which the LSO serves as a guardian. While some coaching may be provided at night over the radio, most daylight recoveries are conducted without any LSO direction beyond an optically signaled call for "power." The LSO's fail-safe course of action is commanding a waveoff, requiring the pilot to setup for a subsequent attempt. The decision to allow any aircraft to continue its approach rests upon the LSO's assessment of the aircraft's predictability: "Is the aircraft within an acceptable range of errors from which to safely land?" and "Is the pilot making appropriate corrections to the observed deviations in glide slope, lineup and AOA?" Since the safety of the landing is established by the point of crossing the ramp, the LSO wants to see an approach such that GS, lineup, and AOA are all stabilized prior to that point, with adequate H/R clearance. The LSO perspective is described in detail in the LSO NATOPS, reference 62.

Waveoff and bolter performance pose the final constraint on the carrier landing. Whether for a poor approach or a foul deck, all carrier-based aircraft must necessarily have a capability for abandoning any approach. Every aircraft has some range limit at which it will hit the ship, regardless of the pilot's input. Waveoff capability (nominally sink distance from initiation) then expresses how close to arrestment the LSO can still command a safe waveoff.

A number of trajectories could satisfy these constraints. The trajectory flown on straight-deck carriers was very different from that in practice today. The modern approach to an angled-deck carrier entails a stabilized GS at constant speed from no less than ½ mile aft of the ship to arrestment. The stabilized GS ensures satisfaction of the touchdown, drift, and H/R constraints. Flying at a specified approach AOA (in lieu of speed) ensures that the aircraft is in the proper attitude for CDP engagement, and that the approach speed and sink rate are within bounds. Flying a specified approach AOA also provides the pilot and LSO with a consistent sight picture. Consequently, every aircraft specific approach looks identical, regardless of its weight or external loading. From the LSO platform, or from the cockpit, the picture looks the same day-to-day, regardless of the other variables. Finally, the stabilized approach maintains a moderate nominal throttle setting, permitting fairly rapid response to MIL power in the event of either waveoff or bolter.

The landing task may be made more challenging by the presence of the ship's burble. The source of the burble is the interference of the structure of the ship with the relative wind, and its influence is felt mainly in the last half mile of the approach to the ship. The ship structures that contribute to burble are primarily the island, the bow of the flight deck, and the corner formed between the end of the angle deck and the rest of the flight deck (the "crotch"). Burble consists of random, periodic, and steady components. The random component is chiefly caused by turbulence in the lee of the ship's island structure. This turbulence is worse when WOD are predominantly aligned with the ship's centerline (axial winds), which place turbulence in the lee of the ship's island structure at the in-close

position of approaching aircraft. The periodic component of burble is associated, in part, with the cyclic pitching motion of the ship. The steady components of burble consist of a reduction in the steady wind and a predominant upwash aft of the ship that are functions of the magnitude of the WOD, and the range from the ship.

The effect of burble on an approaching aircraft is to create deviations in flightpath due to the steady and periodic components, and variations in AOA due to the random components. The latter usually average out, and constitute a distraction to the pilot's concentration on the landing task. Deviations in flightpath require direct compensation by the pilot. The compensation typically consists of reaction to the upwash upon entering the burble (1,000-2,000 ft aft of the ramp), and then anticipating the strong apparent relative downwash upon exiting it. The magnitude and timing of the compensation varies from aircraft-to-aircraft, with WOD, and from ship-to-ship. The latter is the subject of the ACLS certification of ships, in which feed-forward ramps in pitch command are superimposed on the feedback commands sent to the aircraft. The burble is the feature of a carrier approach responsible for pilot comments regarding the desirability of DLC in those aircraft with slow engine reaction times.

Burbles are not considered a major factor in routine shipboard operations, but rather an ever-present feature of the task. Pilots adapt quickly to each ship, subconsciously anticipating the aircraft's reaction to their nominal experience. In rare cases, such as naturally gusting surface winds or large, rapid ship motion, the burble can have a dramatic effect on the pilot's ability to fly a precise approach. Safety of flight can quickly be compromised, which will result in either a higher accident rate or lower boarding rate.

The geometries of both the day and night/instrument approaches terminate with the above description of a stabilized approach. The patterns by which one arrives at the start are different, the VFR pattern allowing for a closer interval between recovering aircraft, while the night/instrument meteorological condition (IMC) pattern optimizes getting the aircraft on conditions without the day visual cues. Each of the patterns have implications on the capability of a suitable design. Details of the procedures can be found in reference 31.

4.4 KEY AIRCRAFT CHARACTERISTICS

4.4.1 GENERAL

A number of distinctive features can and have been incorporated over the history of Naval Aviation to specifically effect the CV approach handling qualities and performance of carrier-based aircraft. This section briefly surveys some of those features.

4.4.2 WING DESIGN

Wing design is one of the most critical features for a CV suitable aircraft. The wing design must balance cruise, maneuver, high-speed, and low-speed performance. Experience has shown that the total required wing area for carrier-based aircraft is generally sized as a result of either carrier launch or recovery requirements. Increased wing area is often used alone or with another variable as a way to improve CV approach. This method is used because it is low risk and improves mission/maneuver

performance while leaving additional growth potential. The drawbacks include increased weight, cost, and spot factor (size) while degrading acceleration time and supersonic performance.

4.4.3 HIGH LIFT SYSTEMS

High lift systems are used to bridge the gap between what is required for up-and-away performance and what is required for low-speed performance. Available options include leading and trailing edge flaps (single or multiple panels), slats, slots, drooped ailerons, and BLC. These options are considered in the early stages of design and often reevaluated as possible options as the design progresses. Often these devices have external hinges or tracks, which make signature integration extremely difficult. Though multiple panel flaps are common-place among commercial aircraft (up to three slots), they have been avoided in carrier-based aircraft due to their complexity and weight, in favor of a single slot.

4.4.4 VARIABLE WING INCIDENCE

Variable wing incidence has seldom been used due to the mechanical complexity. While conceptually a simple way to increase lift relative to the fuselage attitude, the physical integration is challenging. Loads, weight, and maintainability are all adversely impacted. Incorporation of variable wing incidence on the F-8 was required to avoid nosewheel-first or tailpipe-first touchdowns.

4.4.5 VARIABLE WING SWEEP

Variable sweep wings (e.g., F-14) provide for robust aerodynamic performance across the envelope. Variable geometry tailors aerodynamic characteristics to flight mode and can allow for a very broad range of operating conditions. The aerodynamic benefits must be weighed against the significant weight, complexity, maintainability, and signature costs.

4.4.6 BOUNDARY LAYER CONTROL

BLC, such as blowing on all Navy F-4 models, provides powerful enhanced lift in the power approach configuration. While effective, these degrade waveoff by extracting precious thrust from the engine, and have histories of poor maintainability.

4.4.7 APPROACH ANGLE OF ATTACK

Increased approach AOA, though effective at raising the lift coefficient, typically encounters other constraints, such as over-the-nose FOV, FQ, or tail-strike. The V_{pa} criteria predict the highest AOA that can be flown. Naval Unmanned Combat Air Vehicles may not require the use of the full set of CAC due the removal of some constraints such as FOV.

4.4.8 AIRCRAFT APPROACH GROSS WEIGHT

Reduced approach weight/bring-back powerfully affects V_{pa} (by the square root of the weight) but this can greatly reduce the aircraft effectiveness. The current trend toward expensive smart weapons to date has driven the bring-back requirement to a larger, not smaller, capability.

4.4.9 THRUST INCIDENCE

Increased thrust incidence reduces the dependence upon aerodynamic lift, thereby permitting a reduction of V_{pa} . More thrust support and effective thrust angle also improves GS control, but it can be difficult to integrate without compromising the system weight and mission performance elements. Thrust vectoring may provide a means to maintain direct control of the effective thrust angle.

4.4.10 SPEED BRAKES

Many historic Navy aircraft extended speed brakes on CV approach. This provided several benefits. First, the increased drag of the speed brakes moved the bottom of the drag bucket to a lower speed, moving the V_{pa} closer to the frontside of the power-required curve, and thus improving the flightpath stability. Next, the additional drag necessitated a higher mean power setting, with two consequent benefits. A higher mean power point enabled faster, more linear thrust response, thereby improving GS tracking. Furthermore, the higher mean power setting permitted a quicker transition to full power in the event of either bolter or waveoff. This, together with simultaneous stowage of the speed brakes, permitted more rapid achievement of the maximum excess power. While not deployed by the F/A-18A-D models on approach, speed brakes remain a viable means of improving the handling and performance on approach (e.g., operationally deployed EA-6B and F-14).

4.4.11 DIRECT LIFT CONTROL

DLC is a means of controlling the flightpath by a direct input of lift rather than by thrust change or pitch attitude change. To date, DLC has been used in test and evaluation on the F-8 aircraft, and is incorporated in two currently operational fleet aircraft, the F-14 and S-3. The F-8 and F-14 had installations that could make flightpath corrections both up and down. The S-3 installation can only be used for down corrections.

To control flightpath in both directions requires that the aircraft fly the basic approach at less than its best lift configuration so that a configuration change toward its "best lift" configuration will yield a positive change in flightpath. Conversely, a configuration change to an even lower lift configuration will cause a negative change in flightpath. Figure 15 illustrates this situation.

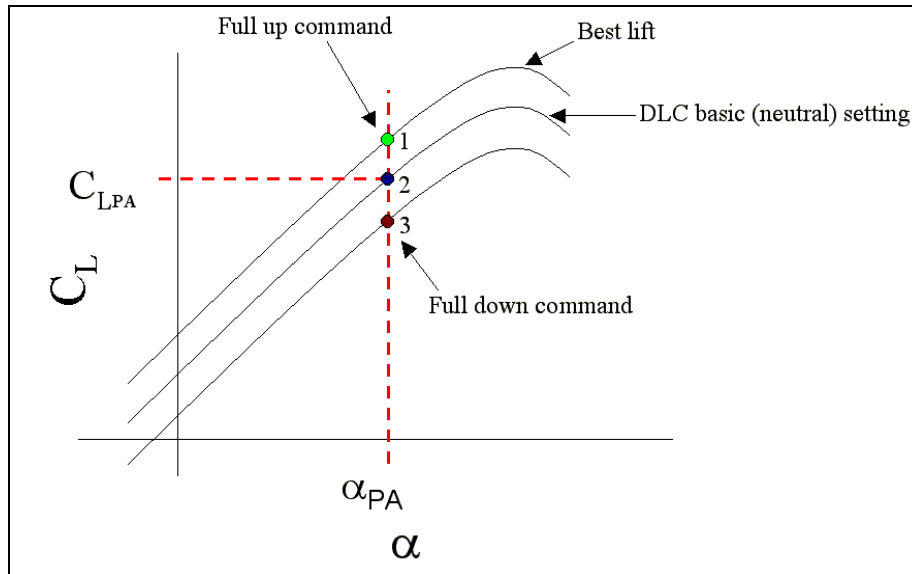

Figure 15: Direct Lift Control

In this figure, the maximum lift capability of the aircraft at the approach AOA occurs at point 1 on the “best lift” curve. In order to use the capability, the basic (or DLC neutral) approach configuration is achieved by configuring the aircraft for less than its best lift capability (point 2). This is achieved in the F-14 by raising the spoilers to a neutral position, thus degrading the lift and increasing V_{pa} at constant α , but providing a positive flightpath change by rapidly moving the spoilers to their “best lift” deflection.

A negative flightpath change is achieved by rapidly moving the spoilers even further away from the best lift deflection to point 3, thereby spoiling more lift. The F-8 accomplished the same type of capability by reducing deflection from the best drooped aileron (similar to using flap) deflection and modulating about this suboptimal position. The S-3 was a variation of this methodology by using the best lift configuration for the basic approach, and changing spoiler deflection for down flightpath change only. In all cases, the configuration changes commanded are interconnected to the longitudinal control surfaces to automatically minimize the trim change, thus maintaining essentially constant AOA.

These systems are quite effective in providing fast response for flightpath control without the need for thrust change or pitch control. Pilot perspective on DLC usage and technique is discussed in Section 4.5.7.

4.4.12 FLY-BY-WIRE/LIGHT FLIGHT CONTROLS

Fly-by-wire flight controls provided the most substantial improvement in V_{pa} in the latter part of the 20th century, by permitting relaxed static longitudinal stability. The camber associated with trailing edge flaps imposes a significant nose-down pitching moment that must be balanced in some way. In a stable, tail-controlled aircraft (elevators or stabilators), the compensating nose-up moment is provided by deflecting the tail down (trailing edge up or TEU). Aircraft such as F-14 Tomcats and early F-18 Hornet models have their horizontal stabilizers trimmed as much as 20 deg TEU on

approach. Consequently, this massive force down on the tail of the aircraft is robbing the aircraft of much of the lift the flaps are intended to provide, leading to an increased V_{pa} . Alternately, the CG can be designed aft, destabilizing the aircraft, but the couple providing the necessary moment to balance the nose-down contribution of the flaps now contribute a nose-up moment. To balance this moment, the tails can therefore be up-loaded, rather than down-loaded, assisting with the production of lift rather than reducing it. In this manner, though the wing loading of the F-18 Hornet was increased 3.5% going from the F-18C to the F-18E models, and the full flap deflection was reduced from 45 to 40 deg, the F-18E/F Super Hornet enjoys a V_{pa} approximately 10 kt slower in part due to these changes between the F-18C and F-18E model. The difference is a trim stabilator setting nearly parallel to the fuselage of an E-model on approach, rather than heavily down-loaded as with the C-model. This reduction in static stability is exclusively attributable to the confidence in control systems technologies to manage naturally unstable systems. It should also be noted that some of the 10 kt F/A-18E/F improvement is due to the sealed wing/shroud and sealed wing fold.

4.4.13 MATERIALS

Finally, composite materials have played a minor role in adding to improvements in V_{pa} . These materials permit designs be tailored for twist and bending in ways that were attainable with aluminum. This has allowed wing designs to use more optimum contours for aerodynamics and less constrained by material properties and production capabilities.

4.5 PILOT PERSPECTIVE

The pilot is the most unpredictable component of the shipboard landing system. "Fatigue" means something completely different to the aircraft than it does for the pilot. The aircraft flies the same on its 5th shipboard landing as it does 200 later. The aircraft does not care whether the sun is up or down. All of these issues, among others, profoundly affect pilot performance, and consequently system performance. Aircraft features and attributes can limit the variability of the performance of the pilot. This section addresses these topics beginning with the pilot as a multivariable sensor and feedback control system.

The human part of this pilot-aircraft system is limited in the ability to control multivariable problems. A human with sufficient control authority can control one dynamic variable very precisely, two variables precisely, three variables passably. The pilot's performance deteriorates severely trying to simultaneously control more than three. Fortunately, the multiple constraints of a CV landing are satisfied by the pilot's control of just three variables – GS, lineup, and AOA. Pilot performance is affected by the allowable tolerance of the accepted deviations, the dynamics of the particular variable, the responsiveness of the aircraft to control inputs, the environmental conditions, and the quality of the information used to determine GS, lineup, and AOA error. It is important to note that tactical Naval Aviators, in the context of CV landings, speak interchangeably about speed and AOA. Though they are reading AOA in their indicators, they refer to themselves as either "fast" or "slow".

One of the substantial operational benefits of CV landings is that they can be performed passively by the pilot using the stabilized optical systems on the ship ("passive" meaning that no Radio Frequency (RF) communication or Navigational Aids are required). Ideally, from the start of the

visual pass ($\frac{1}{2}$ to $\frac{3}{4}$ mile aft), no radio communication takes place between the pilot and LSO other than an optical signal or a simple radio call to confirm open two-way communication. Virtually all day landings are performed "zip lip," meaning that the pilot receives only a flash of green lights to confirm that the aircraft is cleared to land and that the LSO's are monitoring the approach. At night, most landings take place with only a "Roger, Ball" transmitted over the radio signifying the same.

4.5.1 SENSORY INFORMATION

Since the pilot is trying to simultaneously close the loop on three states, the quality of the information provided is vital. GS is provided by the FLOLS that is stabilized in pitch and roll to compensate for pitch and roll movements of the ship. As every aircraft has a different H/E length, the lens is adjusted for each aircraft model, such that if the pilot maintains the central light in the lens aligned with the reference lights ("datum"), the hook will touchdown midway between the second and third CDP. Because the GS information is displayed in a radial fan of light cells, the resolution of the vertical displacement from GS improves with the inverse of distance from the ship. The centerline stripe and lights provide lineup information, as do the drop lights. AOA is provided internal to the cockpit in a variety of displays. These are the primary sources for the three control states.

It is significant to note that GS, lineup, and AOA in and of themselves only provide displacement error. The best closed-loop performance is achieved feeding back error rates rather than displacement errors themselves. Error rates for GS and lineup can only be assessed by monitoring the change in the error over time. For example, a glance at the lens will identify one's location relative to the GS, but will not identify whether the error is increasing or decreasing. Periodic sampling over some finite time is required to discern whether the GS is improving. The same is true for the lineup. In darkness, LSOs contribute significantly in that they can usually detect developing error rates before the pilot.

Heads-Up Displays (HUD's), such as that found in F-14D and all F/A-18 models have dramatically transformed the landing problem. First, an Inertial Navigation System (INS)-driven velocity vector precisely displays the projected flightpath of the aircraft. Ashore, the velocity vector permits a pilot to superimpose the symbology directly on the intended point of landing and achieve very precise results. At sea, since the ship is typically moving relative to the inertial frame, the velocity vector does not reliably indicate the point of touchdown. It does, however, provide very precise rate information with respect to GS, with some small bias term. The typical habit for F-18 Hornet pilots is to place the Velocity Vector near the intersection of the decks ("crotch") of the ship, and then gauge the GS trend. In doing this, the pilot is effectively leading the ship by placing the velocity vector at some point out in front of the wires where the ship and aircraft trajectories will intersect. This initial placement ensures that the flightpath will very nearly hold the aircraft on GS. The precision of the FPA data also means that the effect of an input correction is immediately assessed in a variable that is very nearly GS rate (the state information necessary for the pilot to attain the elevated performance). As the aircraft approaches the in-close to at-the-ramp position, the velocity vector is allowed to drift aft to the point of touchdown. The fielding of HUD's largely bears the responsibility for the improvement in boarding rate demonstrated by F-18 Hornets and F-14D model Tomcats over the aircraft that preceded them. One method to reduce pilot workload during the approach task is to improve pilot cueing. Because of the beneficial impact of HUD cueing on pilot

workload during the approach task, it is recommended that HUD considerations be a primary consideration in designing for the approach task.

In those aircraft without a suitable HUD, the Vertical Speed Indicator (VSI) is the sole cockpit instrument supporting GS maintenance. Since this pneumatic device is typically a console gauge and exhibits considerable lag, it serves little benefit once the pilot transitions scan outside the cockpit. Most VSI's provide an accuracy band of ± 50 fps, approximately double that of a INS-driven velocity vector. Taken together with their lag and peripheral location in a pilot's scan, these factors in part account for the boarding improvements observed in those aircraft with HUD's.

Manual Optical Visual Landing Aid System (MOVLAS) provides an alternative system for providing GS, yet is different from the standard lens in that it can be used to provide both GS error and GS error rate. MOVLAS exists to provide both an emergency means for aircraft recovery in the event of Fresnel lens damage or failure or extreme sea states for which the stabilization system becomes saturated or ship's heave becomes excessive. To the pilot, MOVLAS provides the identical view as a Fresnel lens, and its use should be transparent. Since the "meatball" position is directly controlled by the LSO, a skilled LSO can actually provide the pilot with lead compensation to GS error. Specifically, a pilot on GS, but about to go low, will see a centered ball on a Fresnel lens. With MOVLAS, the LSO may anticipate the aircraft's sink below GS, and show the pilot a "slightly low" before the aircraft actually settles. The result is that the pilot responds earlier with a slight power increase and never actually deviates from the GS. GS tracking is thereby enhanced.

The disadvantage of MOVLAS is that two humans are in the control loop rather than one. If the LSO is highly perceptive and skilled in its use, performance is enhanced. However, the reality is that both of these human components are adaptive, learning control systems and, therefore, susceptible to working against one another. Furthermore, MOVLAS doubles the number of components susceptible to misjudgments or errors of interpretation.

Lineup also suffers for want of direct error rate information; lineup must be monitored for some finite time to discern if the lineup is stable or deteriorating. This is aggravated by the fidelity of the lineup information at range. The pilot may however have good roll attitude information that provides information on lineup error acceleration. AOA is the one state for which the pilot has information from multiple sources. Typically, most cockpits have two or three direct sources of instrumented AOA: the three-color indexers, an analog or digital gauge, and the HUD 'E'-bracket in the case of F/A-18's and F-14D's. Next, all Navy aircraft presently have AOA control systems, whereby, in the steady-state, a longitudinal stick position corresponds to an AOA. This may be the case because aircraft have conventional mechanical or hydraulic controls, or because it employs a fly-by-wire system using AOA feedback in the power approach configuration (e.g.- F/A-18 models). Therefore, if the aircraft is trimmed for the approach AOA, any displacement from neutral longitudinal stick represents an AOA error. Alternatively, many pilots deliberately trim their aircraft a little nose heavy, in which case they know the "feel" of an onspeed aircraft. In either case, the pilot has tactile feedback of deviations from the ideal. Finally, since the horizon is in a consistent position relative to the canopy, the pilot develops a subconscious awareness of the right approach attitude with experience at the ship. This information is clearly absent during dark night operations, which is one of the reasons Navy pilots are so fond of a bright moon. All of the above provide the pilot with a multisensory feel for the AOA in a way that does not require cognitive interpretation such as lineup

or GS, which is entirely visual. Consequentially, the AOA instrumentation operates in the periphery of the experienced pilot's scan, rather than something that requires active, focused attention.

Speed (AOA) control is also the only state for which the pilot has some direct sense of the error rate. Direct accelerations on the pilot's body are sensed and provide some feedback on airspeed rate. The sensitivity is not very high, but gross accelerations or decelerations can be felt "seat of the pants". Small but significant acceleration or deceleration rates may be below the threshold of recognition, evidenced by some F-14A/B pilots using their Radar Intercept Officers to monitor the airspeed indicator for abrupt changes that might escape the pilot's attention. Additionally, cockpit noise from aircraft engines or air conditioning system may provide some feedback on engine acceleration or deceleration, and thereby another clue to imminent changes in the aircraft AOA. From the LSO perspective, power trends can be roughly discerned both audibly (fan noise) and visually (engine exhaust).

The F-14D HUD incorporates one additional unique feature germane to the landing task. Copying a feature introduced on the Mirage 2000 aircraft (an aircraft that operated severely on the back-side during approach), a caret appears to the right of the velocity vector indicating longitudinal acceleration. If the caret is above the velocity vector, the aircraft is accelerating; conversely, if below, the aircraft is decelerating. This source of speed rate provides for very precise control of airspeed under a range of flight conditions, and provides superior signal quality to any of the indirect means by which a pilot might otherwise judge speed control. The feature was included in the flight test hardware of the F/A-18E/F development test articles and contributed significantly to the efficiency of the flight test effort, but its inclusion in the production software load was inexplicably declined by operators who did not understand its value. Considerable experience and data exist that demonstrate the value of this information to improve quality of speed regulation in cruise and approach flight conditions.

4.5.2 DAY/NIGHT DISTINCTIONS

During the day, the pattern begins with a semicircular arc commenced approximately 1.2 miles abeam the ship. Given a good abeam position, a shallow descent and 20-25 deg AOB will deliver the aircraft to the start position with 15-20 sec of time stabilized on course and on GS. One of the challenges peculiar to the day pattern is that if the turn is flown at the onspeed AOA, upon rolling to wings-level, the aircraft is actually too fast. The result is a series of immediate power adjustments to establish the proper onspeed AOA. With experience, pilots learn the appropriate correction magnitudes to quickly stabilize. The reality is that at the start, the three desired control states are not truly stabilized. (Note: one technique available to those aircraft with DLC is using it to instantaneously dump the surplus speed steadying up out of the turn to more quickly capture stabilized conditions. This is very common among F-14 pilots.) The nonstabilized nature of the day pattern introduces a complexity not present at night, and in fact there is a substantial minority of pilots whose night landing grades are better than the day because they benefit from the extended opportunity at night to stabilize these three aircraft states at range from the ship.

The turn-to-final also provides for much wider variability in the start conditions. The greatest variability occurs with the lineup. An undershooting start is easily rectified, and a slightly undershooting start is slightly advantageous because the bank angle is slowly reduced out of the

turn, permitting a smoother capture of the appropriate speed. An overshooting start is the most challenging of the start errors. A steep AOB results crossing the ship's wake, and is held as the aircraft crosses centerline and develops drift back towards the extended centerline. As the aircraft approaches the centerline, an abrupt turn to the right is required to capture centerline. The lineup error necessarily creates errors in both GS and speed. Because of the steep bank angle, the pilot is compelled to carry considerably more power and speed than needed once stabilized. Additionally, there is no time to concentrate on the speed or GS errors until the pilot's lineup is resolved. With lineup wrestled back under control, the pilot usually has to cope with a severely overpowered condition that developed while correcting lineup. This is the scenario that is most taxing on the aircraft handling qualities (particularly roll performance and control), as well as the engine response. The variability of start position relative to GS has improved significantly since the introduction of the HUD that accurately depicts the FPA. Providing immediate precision flightpath information dramatically simplifies the task of consistently capturing GS at the start.

Day flying at the ship has several substantial advantages over night operation. Foremost is the quality of the sensory information. A horizon on all sides is a reliable attitude indicator. Because approaches are flown at a constant AOA, regardless of the weight, the horizon is always across the same spot of the canopy when stabilized on approach (slight variation with wind conditions). This aids in setting and perceiving changes from the approach AOA. With a horizon running from periphery to periphery of one's vision, precise wings level is maintained subconsciously. If the wings are level, then the lineup error may be increasing, but it is not accelerating. Consequently, the lineup problem is dramatically simplified, once established close to centerline. Additionally, under all but the most severe wind conditions, the ship will be translating through the water leaving a visible wake. Though the wake does not coincide with the final bearing, it is always in the same place relative to the final bearing. The wake is, therefore, an unmistakable daytime aid in resolving the lineup.

Night landings pose a different challenge. The approach trajectory is much simpler since airspeed, lineup, and GS are stabilized long before the start as a consequence of the straight-in instrument approach from 5-6 miles aft. Presuming a good start, the challenge is instead the quality of the information available to the pilot to keep the errors small from the start to touchdown. Because of the erosion in the quality of the pilot's sensory information, LSO's will be much more forgiving during the day than night. Pilots are afforded the opportunity to fix approach errors that during the day that at night would be waved off without hesitation. Consequently, aircraft control power is seldom stressed at night; as the LSO's do not allow either large errors to develop or large corrections to be made. Both large errors and large corrections evaporate the LSO's confidence in the predictability of the flightpath, leading to a mandated waveoff.

Losing the natural horizon is the most serious consequence of night approaches (one can thereby speak almost interchangeably of night and day-instrument approaches). Under either night or severe instrument conditions, the pilot is deprived of the precise subliminal attitude information available during the day. The loss of the horizon over the nose is probably the least severe as it serves as only a subtle support to other sources of pitch attitude and AOA. However, dark nights cripple the roll attitude information provided the pilot. First, the resolution roll data provided by the natural horizon, extending fully to either side of the pilot's peripheral vision, dramatically exceeds the resolution of any instrument attitude source, which subtends a much smaller angle of the pilot's available FOV. A

HUD-equipped aircraft is dramatically superior to those without a HUD, but still exhibits degraded resolution compared to the natural horizon. Those aircraft without a HUD are constrained to using the ship itself as the attitude reference. From the start to in-the-middle, the ship subtends such a tiny angle within the pilot's optical FOV that the ability to resolve roll attitude may be no better than ± 5 deg. Consequently, an unperceived small roll angle may develop a substantial lineup error rate before the pilot detects the building error. Next, the interpretive effort required of the pilot exceeds that required during the day with the natural horizon. Finally, the loss of the natural peripheral horizon introduces the specter of vertigo, adding a physiological obstacle to the performance of the pilot as a control system. The erosion of the roll data compels the pilot to devote more direct attention to lineup control, thereby cutting into pilot concentration on GS.

4.5.3 GLIDE SLOPE TECHNIQUE

The CV approach is typically described as requiring a "back-side" technique, as opposed to the more common "frontside" technique used for landing aircraft ashore. The expressions "front-side" and "back-side" refer to the power required curve and whether the aircraft is operating on the front-side where parasitic drag prevails and drag increases with speed, or the back-side, where induced drag prevails, and total drag decreases with increased speed.

On the front-side, an aircraft has positive flightpath stability. In response to a small, square-wave longitudinal stick displacement aft, the aircraft's flightpath will shift up, and the speed stabilized at some slightly lower value. For landing such an aircraft, the longitudinal stick can be used principally to control flightpath, and the throttles adjusted in response to reset the speed. Longitudinal stick purely controls flightpath; throttles control speed.

On the back-side, the aircraft has negative flightpath stability. In response to a small, square-wave longitudinal stick displacement aft, the aircraft's flightpath will momentarily shift up, and the speed will decrease. Increased sink rate is the steady state response to aft longitudinal stick. Since the aircraft is now underpowered, a sink rate will develop in order to regain the lost speed. A different technique is therefore recommended. Longitudinal stick is nominally thought of as controlling AOA, and throttle is used to set the sink rate. Power is reduced to increase sink rate, or added to decrease sink-rate. In reality, the controls are not as purely decoupled as in the front-side method. Since many USN aircraft with both mechanical and fly-by-wire flight controls have AOA control in the longitudinal direction, AOA (speed) control requires no active pilot management. The stable short period mode facilitates the capture and maintenance of AOA. Sink rate, however, does not respond rapidly to throttle changes. First there are significant lags in engine response to throttle (particularly with large turbofan engines). Secondly, the speed must actually vary, and then the flightpath adjusts through the phugoid mode with its slower dynamic character. Consequently, the back-side technique involves a blend of control inputs, the weighting varying from pilot to pilot. A sink-rate adjustment up, for example, will be performed by both a power increase, and a slight, brief aft longitudinal stick input. The longitudinal stick input provides the immediacy of response, while the power adjustment provides for the steady-state flightpath change. Once the power starts to catch up with the new flightpath, longitudinal stick can be returned to trim. The stick is therefore used to provide the desired transient dynamics while the power is used to provide the steady state. Pilots new to the CV approach task are coached to consider a string tied at each end to the stick and throttle, and passing

around the back of their neck. Increasing power entails a little aft longitudinal stick; pulling power entails a little forward longitudinal stick.

4.5.4 AUTOTHROTTLE ISSUES

4.5.4.1 Traditional Autothrottles

Implementation of modern autothrottles (also referred to as APC) is a vestige of legacy aircraft with mechanical control systems. All current APC systems are designed to regulate AOA to the preset approach power setting. Once engaged, the throttle is commanded either mechanically or electrically to restore the aircraft to its fixed approach AOA. If the AOA is less than the approach value, the throttle will retard; if the AOA is high, the throttle will advance. Because the throttle setting is actually several states removed from the AOA, lead filtering is frequently performed employing longitudinal stick position, stick rate, or N_z to accelerate the response.

This APC architecture is a legacy from aircraft models that predate either fly-by-wire or throttle-by-wire. With a mechanical control system (e.g., F-4, A-4, A-7, F-14, A-6), the APC could use the AOA signal from the AOA probe or vane, passing through a small throttle computer driving the mechanical throttle quadrant. Such a system could be independent of the flight control system, with perhaps only an augmentation signal from an accelerometer or stick position sensor. This architecture has carried directly into more sophisticated aircraft with only minor variation.

Since the APC is using throttle to regulate speed, stick now controls sink-rate and the pilot is *de facto* flying a front-side technique. While the stick remains an AOA controller, it appears to perform as a FPA controller. This initially seems confusing, as the longitudinal stick and throttle are both commanding AOA. The system works well because of their complementary functions. Assume the pilot has trimmed the aircraft for hands-off at the approach AOA. Through the short-period mode, the aircraft responds to a step forward stick movement by stabilizing at an AOA lower than trim. The APC perceives the AOA error as "fast" and retards the throttle. Once the desired flightpath is attained, the stick can be recentered. While setting APC gains can be a lengthy process during developmental simulation and flight test, experience has shown that the end performance of these systems is excellent. A significant minority of fleet pilots will opt for APC every approach. Another subset prefers APC at night and manual control during the day.

Though not prevalent, deliberately flying off-trim is a common pilot technique. A small percentage of those preferring APC generally opt to trim the aircraft for an AOA slightly less than the approach value. Onspeed, the pilot will therefore be holding 2-3 lb of aft stick. Proponents cite the following advantages. First, for those aircraft with mechanical linkages to the servo-actuators, all free-play is removed from the linkages, moving the free-play band away from the range of stick deflections being used for the task. Secondly, even the fly-by-wire aircraft have a dead band around neutral, through which there is necessarily a nonlinear response. Proponents reasonably insist that they can more precisely modulate the stick position around some constant bias aft stick pressure than they can through the dead band where the hand and arm must change from pulling to pushing. Finally, some suggest that the psychology of night approaches is such that there is a subconscious aversion to pushing nose down at night when the water is unseen; it is a much easier matter to simply relax aft stick.

4.5.4.2 Alternate Control Paradigms

Though autothrottle systems on carrier-based aircraft have used AOA feedback since the mid 1960's, other control strategies exist which might be suitable for the task. Similarly, the control systems of CV based aircraft have all implemented AOA longitudinal control. Even advanced fly-by-wire USN aircraft have implemented control laws that imitate the dynamics of a conventional aircraft. These fly-by-wire aircraft (notably the F/A-18) add outer-loop throttle control to the inner-loop feedbacks for the aircraft dynamics.

Several prototype aircraft have used speed-hold, instead of AOA feedback. An example is the F-15 STOL/Maneuvering Technology Demonstrator (S/MTD) aircraft. This Advanced Technology Demonstrator included precision landing among its demonstration tasks. The longitudinal control system was a pitch command system (longitudinal stick deflections from neutral generated a pitch rate). A neutral longitudinal stick commanded constant pitch attitude. A control system that included the capability for high bandwidth longitudinal thrust variation and tight control of airspeed provided the pilot with precision flightpath control through the longitudinal stick. Pilots observed that the flightpath performance of the S/MTD was outstanding, but the thrust hardware architecture necessary to provide the airspeed control was fraught with mechanical problems and costs that did not seem feasible for a production aircraft.

For aircraft with fly-by-wire and throttle-by-wire control systems, there are a number of control strategies that could provide the requisite performance when implemented in an integrated flight and propulsion control (IFPC) system. Because the propulsion systems have not historically been required to meet the stringent reliability standards of flight control systems (e.g., levels of redundancy), the USN has remained dependent upon control strategies in software that mimicked those of legacy aircraft. Though the S/MTD propulsion control implementation was problematic, the S/MTD proved that alternative strategies exist that may improve safety and efficiency. The discussion above pertains to alternative architectures available through IFPC architectures for approach power and longitudinal control. A corollary discussion is the use of alternative longitudinal control architectures with manual throttles. For power approach configuration, the most common alternative control strategy is pitch rate feedback, present in both the F-16 and the Mirage 2000. With a pitch rate feedback control system, the throttles control speed, and AOA control is secondary. Consequently, with neutral longitudinal stick (pitch attitude is therefore constant), a throttle change results in both a speed change and a change in FPA. In the F-16, this does not lend itself to precision touchdown control. In the Mirage 2000, a back-sided delta-wing aircraft, precise GS tracking is achieved by providing useful HUD sensory cues that assist the pilot to smoothly integrate the throttle and longitudinal control. However, with manual-throttles control, AOA feedback systems would seem to be at an advantage over pilot control of AOA through the short-period mode, since the former system affords the pilot more attention to the GS control task. Nevertheless, the advances in alternative paradigms indicate that the USN may benefit by investigating other architectures of longitudinal and thrust control that can be demonstrated to satisfy the trajectory. This may include abandoning any manual control of thrust in the power approach configuration.

4.5.5 LINEUP

Many of the historical carrier-based accidents are caused by lateral excursions from the landing area during some part of either the landing rollout or a bolter. Since the most common foul-line excursions result in Class 'B' or 'C' (i.e., no loss of crew or aircraft) damage, and lack the dramatic effect of a ramp strike, they do not receive the same attention. Moreover, if the aircraft lands within the wires (within the acceptable GS error band), a successful landing is fairly insensitive to errors in GS rate (sink rate). While the nominal sink rate of 14 fps is prescribed, aircraft loads are certified to sink rates in excess of 20 fps. With respect to lineup, it is not sufficient that an aircraft touchdown within a specified distance of the centerline; it is also vital that the aircraft touchdown with little lateral drift to keep the wingtips within the bounds of the foul line throughout the rollout. Carrier aviation has a lengthy history of aircraft touching down directly on centerline, but then impacting parked or taxiing aircraft with a wingtip during a rollout. For this reason, the backup LSO's principal responsibility is to monitor the lineup of each approaching aircraft. As mentioned previously, lineup control is significantly aggravated by the erosion of sensory information at night, requiring the pilot to devote more attention to lineup to the detriment of the control of the other aircraft states.

4.5.6 WAVEOFF

Approaches terminate with a waveoff whenever the deck is not ready or the LSO's lose confidence that the approach can safely be continued. The principal figure of merit (FOM) is minimizing the altitude lost from the initiation of the waveoff. The procedure for waveoff must be simple, with no unusual control requirements. Typical fleet aircraft call for either holding constant pitch attitude until climbing, or maintaining constant AOA. Those aircraft so equipped automatically stow speed brakes and DLC. In the case of the DLC aircraft, its stowage provides an immediate speed margin above the speed for approach AOA.

4.5.7 DIRECT LIFT CONTROL

As discussed in Section 4.4.11, several carrier-based aircraft have implemented DLC systems as an auxiliary controller. The F-14 and S-3 use spoiler modulation for DLC, with the F-14 capable of "Up" and "Down" DLC and the S-3 capable of "Down only" DLC. The F-14 system has matured since its original implementation. The original full span spoilers were trusted to be effective only when used in the down direction, and then only as discrete bumps. Many pilots used them only in the VFR turn-to-final to abruptly dump the extra airspeed held around the turn. Another effective use of DLC was to save an overpowered condition at the ramp, in hopes of dropping the aircraft onto the 4-wire. The subsequent implementation provided considerably more DLC power, both up and down. For example, some pilots found that judicious use of Up-DLC passing the burble effectively checks a settle, while minimizing the likelihood of getting overpowered and boltering. The problem with DLC used in this sense is that the pilot is now manipulating three inputs (throttle, longitudinal stick, and DLC) to control two states (GS and AOA). This was overwhelming for many pilots, who disregarded its use altogether until they had become proficient without it, and then used it sporadically. Pilots who learned to effectively use DLC found that it provided a faster response in altering flightpath than was achievable through the indirect means of pitch changes or throttle adjustments. Additionally, a last-second DLC input to drop the flightpath does not exhibit the adverse effects of either: 1) landing underpowered (and hence a long spool-up in the event of a

bolter), or 2) a large nose-down movement crossing the ramp, which both raises the hook and the ire of LSO's. DLC offers improvements to flightpath control, particularly with respect to fast response. In order to minimize pilot workload and maximize the effectiveness of the system, it is desired that future implementations of DLC be transparent to the pilot within the inner-loops of the flight controls.

4.5.8 ENGINE INOPERATIVE (FOR MULTI-ENGINE AIRCRAFT)

For multiengine aircraft, single-engine approaches to the ship are among the most challenging emergencies. In some cases, the thrust asymmetry severely degrades the handling qualities. In other aircraft, the waveoff performance is severely compromised. For some aircraft (e.g., F-14 models), loss of an engine necessitates a change in the approach AOA. Changing the single-engine approach AOA is undesirable since the eyes of the pilot and LSO, as well as all the instrumentation (e.g., approach lights and indexers), are accustomed for the nominal approach AOA. Precise control of the airspeed is therefore degraded. While this is immaterial for shore landings, this further complicates the shipboard-landing task. In the case of F/A-18 models, the flaps are retracted slightly for single-engine approaches. This is viewed as a preferable approach to solving the single-engine problem, in that fewer variables are changed with respect to how a pilot handles the aircraft. Adjustments in flap configuration to raise V_{pa} , without changing the approach AOA, are preferable to altering the approach AOA for single-engine recovery.

4.6 LANDING SIGNAL OFFICER PERSPECTIVE

4.6.1 RESPONSIBILITIES

The LSO primary responsibility is “the safe and expeditious recovery of fixed-wing aircraft aboard ship.” Aircraft performance and FQ are necessarily considered by the LSO as he/she controls and assists aircraft during approach to landing aboard ship. The LSO continuously and simultaneously monitors GS, lineup, and AOA looking for deviations from the ideal. The LSO aids the pilot by providing a redundant information source to evaluate trajectory trends and provide guidance to advise the pilot of corrective action. The timing and urgency of the LSO calls are a function of the deviation magnitudes and rates, as well as the basic aircraft response characteristics or ability to correct for these deviations. Excessive settle on GS may be noted by the LSO prior to the pilot becoming aware of the situation, thus saving valuable time on the initiation of the correction. The LSO monitors the aircraft spatial geometry (pitch and roll attitude, heading), speed (through AOA indexer lights on the nose gear), sink rate, and lateral drift rate to evaluate if the aircraft is and will remain within acceptable thresholds. Therefore, the LSO “picture” and course of action is a complex combination of aircraft physical characteristics (wingspan, H/E distance, FOV, etc.), FQ (roll rate, AOA control, V_{pa} , etc.) and performance (power response, idle thrust, waveoff, etc.). Those enhancements that improve FQ or performance of the aircraft in the approach environment will also make the LSO's job easier as larger deviations can be tolerated and the pilot can more easily execute corrections. Thus, future improvements in aircraft FQ and performance will expand the LSO's waveoff window and reduce the number of waveoffs.

4.6.2 LANDING SIGNAL OFFICER SURVEY

A survey of LSO's was conducted in the first half of 2001 as part of this study, reference 65. Results were compiled from 37 LSO's representing all Carrier Air Groups and AIRLANT and AIRPAC. LSO's were asked to rank the F/A-18A-D, F-14A-D, E-2/C-2, EA-6B, and S-3 from 1 (best) to 5 (worst) in terms of ease of bringing the aircraft aboard the CV. The results are presented in figure 16. Within the scope of the survey, LSO's rated the S-3 as the easiest to bring aboard the CV and the F-14 the hardest. The F/A-18 was a close second to the S-3, and neither platform received a rating lower than 3. The highest standard deviation of the data occurred for the E-2/C-2 aircraft. A review of selected LSO comments indicate that some LSO's found this platform easy to board because of its relatively slow V_{pa} and throttle response characteristics while other LSO's found it difficult to board due to its proximity to stall and lineup characteristics. The results of this survey are consistent with a similar LSO survey conducted in 1992, reference 39 (see Section 2.6.6).

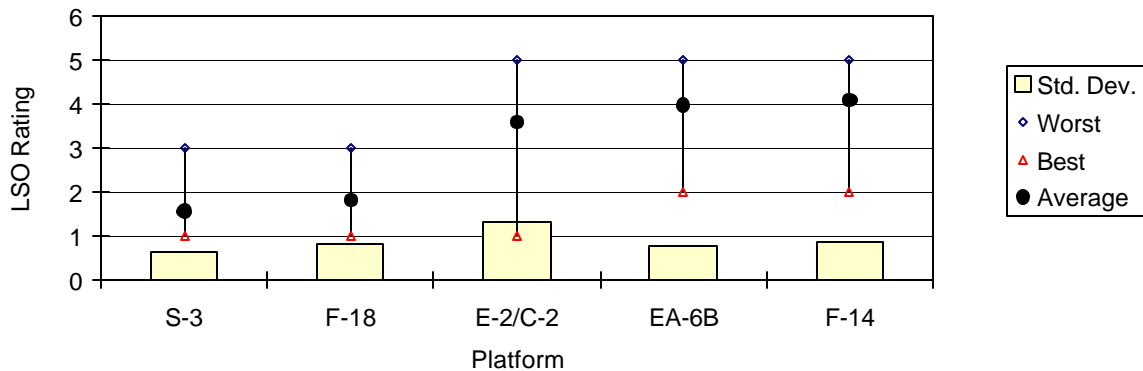

Figure 16: LSO Survey Results

Selective LSO comments accompanying the quantitative rankings indicated that rapid engine response was the most frequently cited aircraft attribute to ensure high boarding rates and safety. The comments suggest that the S-3 and F-18 were rated high due, in part, to their rapid engine responses. Other highly desirable aircraft attributes included slow closure speeds, DLC, excellent lateral-directional control, and effective HUD cueing. Within the scope of the survey, LSO's cited high closure speeds, large H/E distances, poor gust response characteristics, poor lateral-directional control, and hook skip tendencies as undesirable for adequate boarding rates and safety.

4.7 SAFETY IMPLICATIONS

4.7.1 GENERAL

Conventional "wisdom" has been to associate higher V_{pa} with increased aircraft mishap rate. It has been stated by both USN pilots and some within the NAVAIRSYSCOM engineering community that "as V_{pa} increases, so does mishap rate". Based on this observation and the potential

implications to this study, it became necessary to review and address this claim to determine if a factual foundation existed in today's CV environment.

Review of NSC data, reference 3, from 1964 provided a historical reference point whereby Vpa and mishap rate were studied and reported in reference 66. These data, presented in figure 17, illustrate a correlation of mishap rate to Vpa from an early aircraft design vintage. With significant engineering and technological advances in propulsion systems, control systems, aircraft design, and with an additional 35+ years of experience in Naval aviation where the mishap rate of all aircraft has significantly decreased over time, it was questioned if the correlation illustrated in figure 17 was applicable in 2001. Therefore, a review was conducted of more recent data to address this question.

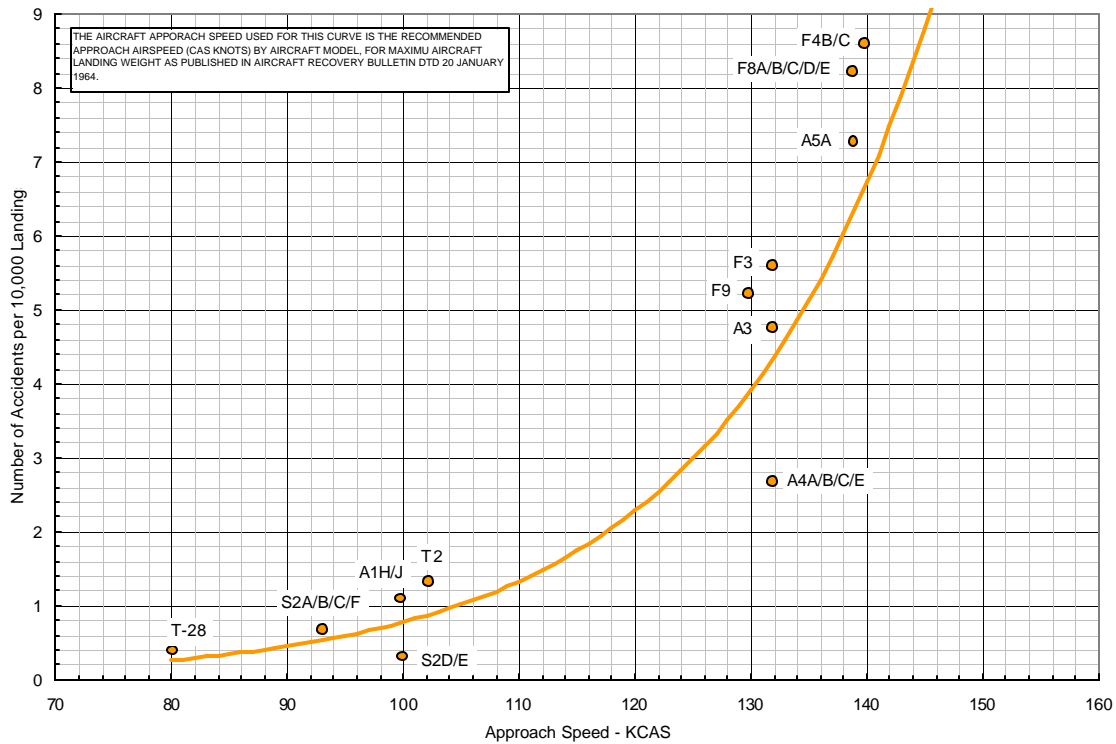

Figure 17: Vpa versus Aircraft Mishaps per 10,000 Landings (1964)

The review was limited to data obtained over the past 20 years (January 1980 through May 2001), reference 4. This time period was dictated by data readily available from the NSC as well as providing a more recent aircraft design vintage than those evaluated in 1964.

4.7.2 ANALYSIS

Based on a data query of all mishaps associated with carrier approach, a total of 144 mishaps was reported, reference 4. This population included both rotary-wing and vertical/short takeoff and landing aircraft approaching to aboard LHA/LHD carriers. The mishaps were organized by platform and the conditions of the mishaps were evaluated. The data were scrutinized removing any mishaps

that were not directly attributed to the CV approach task. The categories used to exclude mishaps from the original population are provided in table 5 and described as follows:

- a) Rotary Wing – All rotary wing platforms were excluded from the mishap population.
- b) Carrier Launch – These mishaps were associated with material failure during catapult launch. Typical failures included blown tires and landing gear structural failure.
- c) Structural / Mechanical / System Failure – Mishaps associated with structural, mechanical, or onboard system failures during flight.
- d) Ordnance / Stores – Mishaps associated with loss of ordnance/stores departing aircraft.
- e) Propulsion System Failure – Mishaps associated with propulsion system failures leading to one-engine-out flight or loss of power.
- f) Divert – Mishaps that were associated with a divert to an airfield. These mishaps were not considered relevant to the CV approach task.
- g) Foreign Object Damage (FOD) – Mishaps that resulted in damage to aircraft as a result of FOD.
- h) Foul Deck – Mishaps associated with foul deck. These mishaps were not considered relevant to Vpa.
- i) Bolter – Mishaps associated with the execution of a Bolter. These mishaps were related to the actual execution of the bolter maneuver. Low engine power resulting in aircraft settle were typical causes.
- j) STOVL (AV-8B) – All AV-8B mishaps were excluded.
- k) Arrestment – Mishaps associated with aircraft arrestment. These mishaps were associated with tailhook and CDP failures.
- l) Pattern/Transition – Mishaps associated with flight in the carrier pattern or during transition from the Marshall stack. These mishaps were not considered associated with the Vpa.

Table 5: Summary of Mishaps Associated with the CV Approach Phase

Rotary Wing	21
System Failure	20
Carrier Arrestment	14
Propulsion System Failure	10
Ordnance / Stores	8
Pattern/Transition	6
Carrier Launch	4
Foul Deck	4
Bolter	4
STOVL (AV-8B)	3
Divert	2
Foreign Object Damage	2
Total:	98

From table 5, it is seen that the majority of mishaps from reference 4 were not considered relevant to the CV approach task. However, removing the table 5 mishaps from the original population resulted in a total of 46 relevant mishaps remaining. These mishaps are summarized by aircraft model type in figure 18.

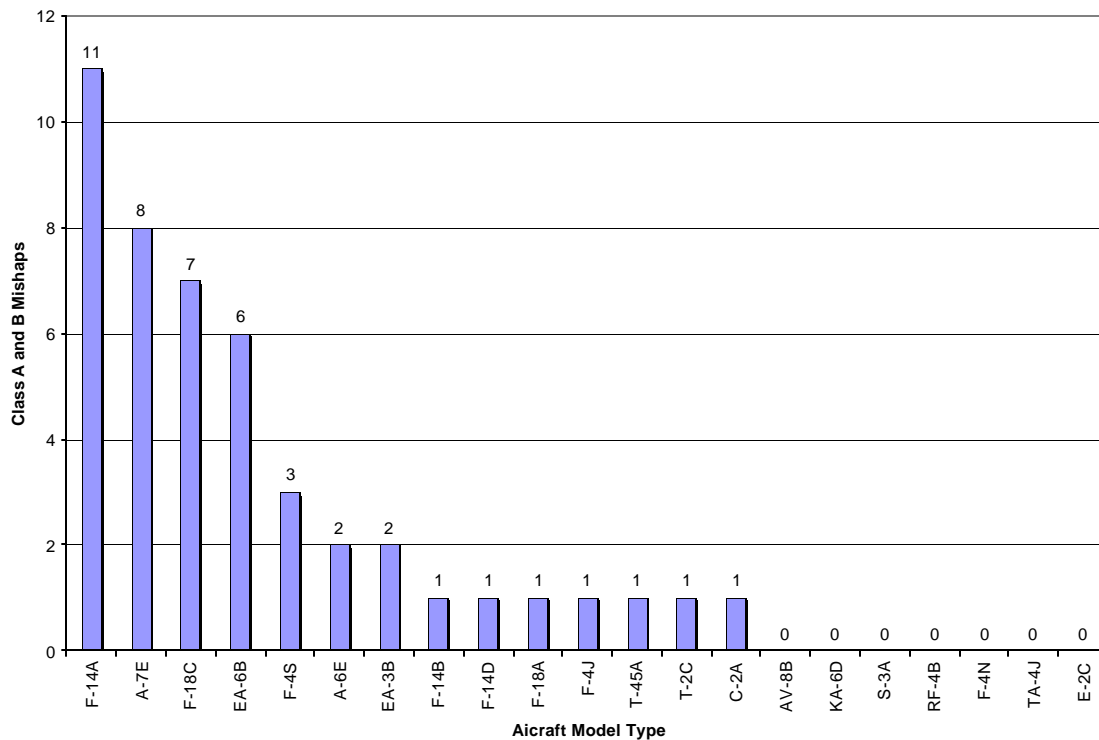

Figure 18: Mishaps Associated with the CV Approach Task (January 1980 - May 2001)

The figure 18 data were then compared against the associated Vpa. Actual aircraft GW and Vpa were not readily available from the NSC for each mishap. Therefore, to determine if a correlation existed between Vpa and mishap rate, each aircraft's maximum Vpa was compared against the number of mishaps presented in figure 18. The results are presented in figure 19.

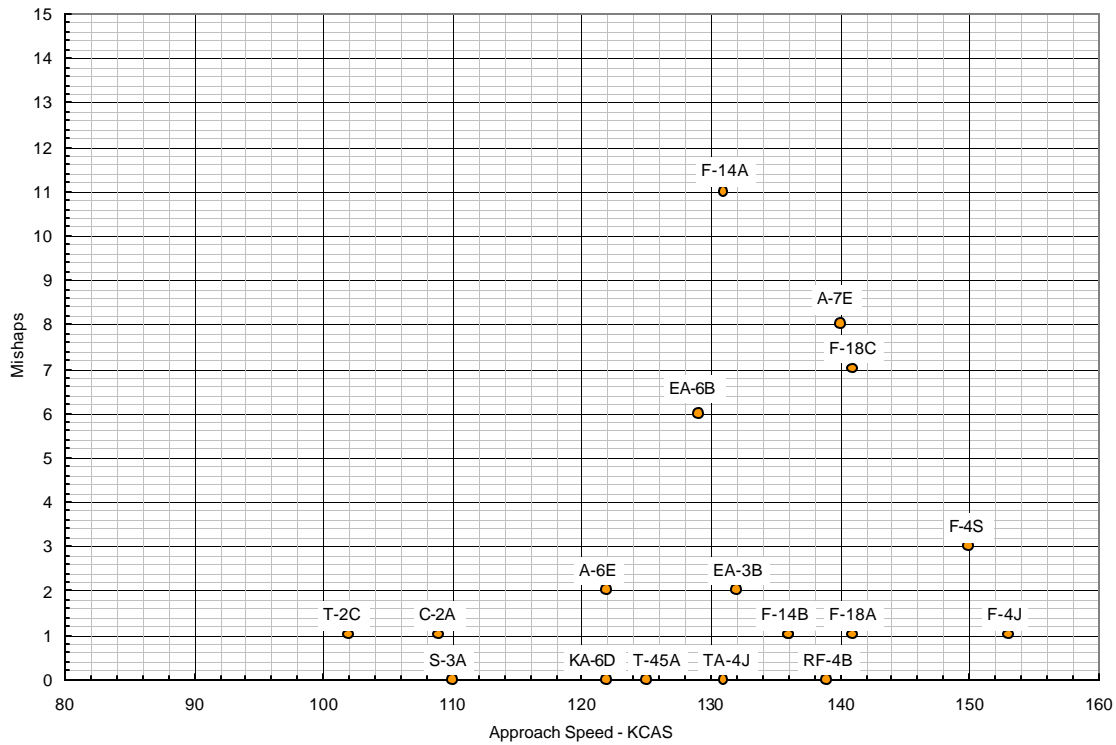

Figure 19: Mishaps versus Approach Speed (January 1980 - May 2001)

Data were further refined to assist in addressing each aircraft's exposure to the CV approach task. This was necessary to normalize the data. This was accomplished for each aircraft by dividing the number of mishaps by the total number of embarked landings conducted during the time period and normalizing based on 10,000 embarked landings. This approach also maintained consistency with data presented in figure 17. These data are presented in figure 20.

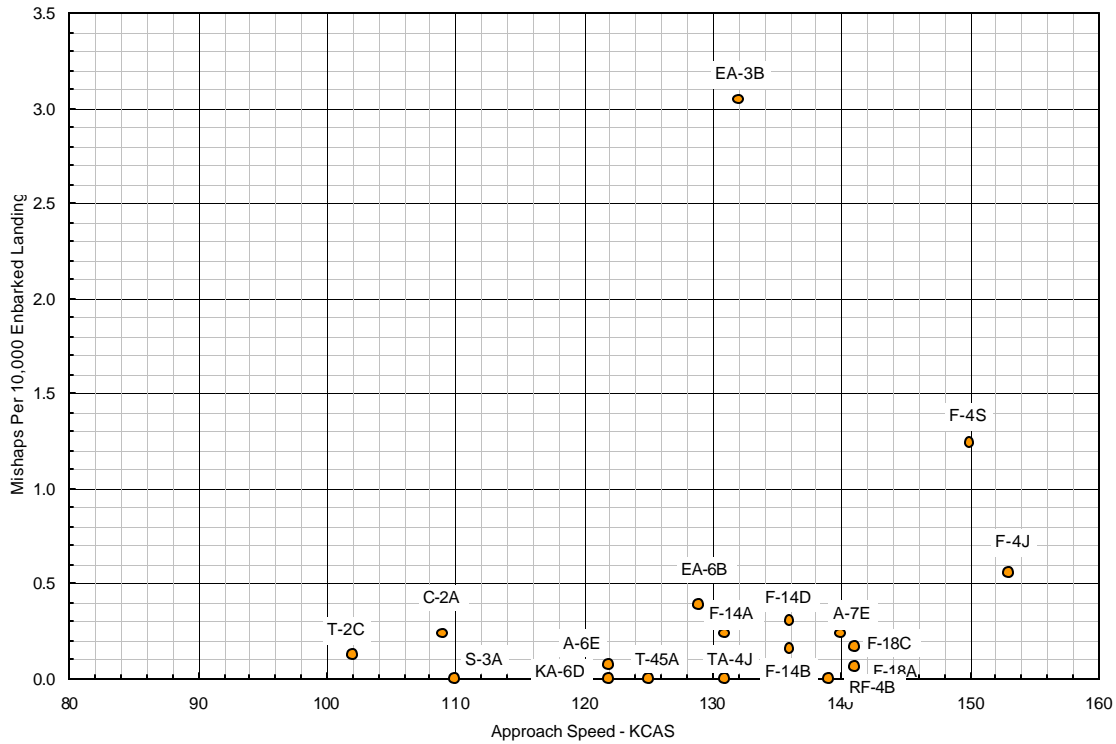

Figure 20: Mishaps per 10,000 CV Landings versus Approach Speed (January 1980 - May 2001)

Figure 20 illustrates the insensitivity of mishap rate to Vpa. It should be noted from the figure that the F-4S, F-4J, and EA-3B are all of an older design vintage and were retired from USN fleet service by the early 1990's. From figure 20, it is concluded that no correlation can be credibly deduced between mishap rate and Vpa. Further comparison to the figure 17 data are presented in figure 21 to assess the conclusion derived in 1964.

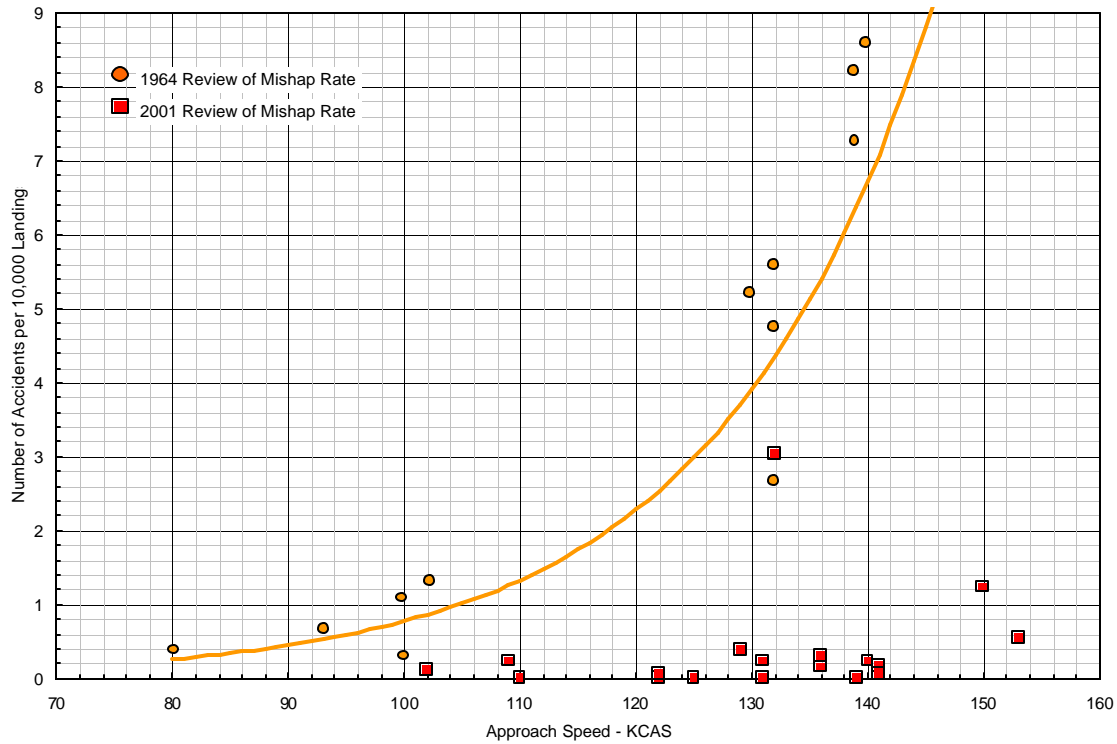

Figure 21: CV Approach Mishap Data Comparison (1964 versus 2001)

Figure 21 illustrates the difference between data obtained and analyzed in 1964 and those from 2001. Each data set is assessing mishap rate based on 10,000 embarked landings. As is depicted from this review, the 1964 conclusion of a correlation of mishap rate as a function of Vpa is not supported by the 2001 results. Over the past 35+ years, advancements in technology, training, and operating procedures appear to have a stronger contribution to the dramatic reduction in mishaps during the approach phase. This is illustrated in figure 22. From the early 1950's through the mid-1960's, there were significant changes made to the CV and operating procedures that still exist today. They include, in part, the introduction of the mirror landing system, angled-deck carriers, and the introduction of standardization of operating procedures through the use of the NATOPS. Therefore, based on these data, it is concluded that there is no longer a correlation between mishap rate and Vpa within the scope of aircraft reviewed and, therefore, should not be used as an indicator of safety. However, it should not be construed that a correlation between Vpa and mishap rate does not exist for Vpa greater than those surveyed (i.e., 153 kt).

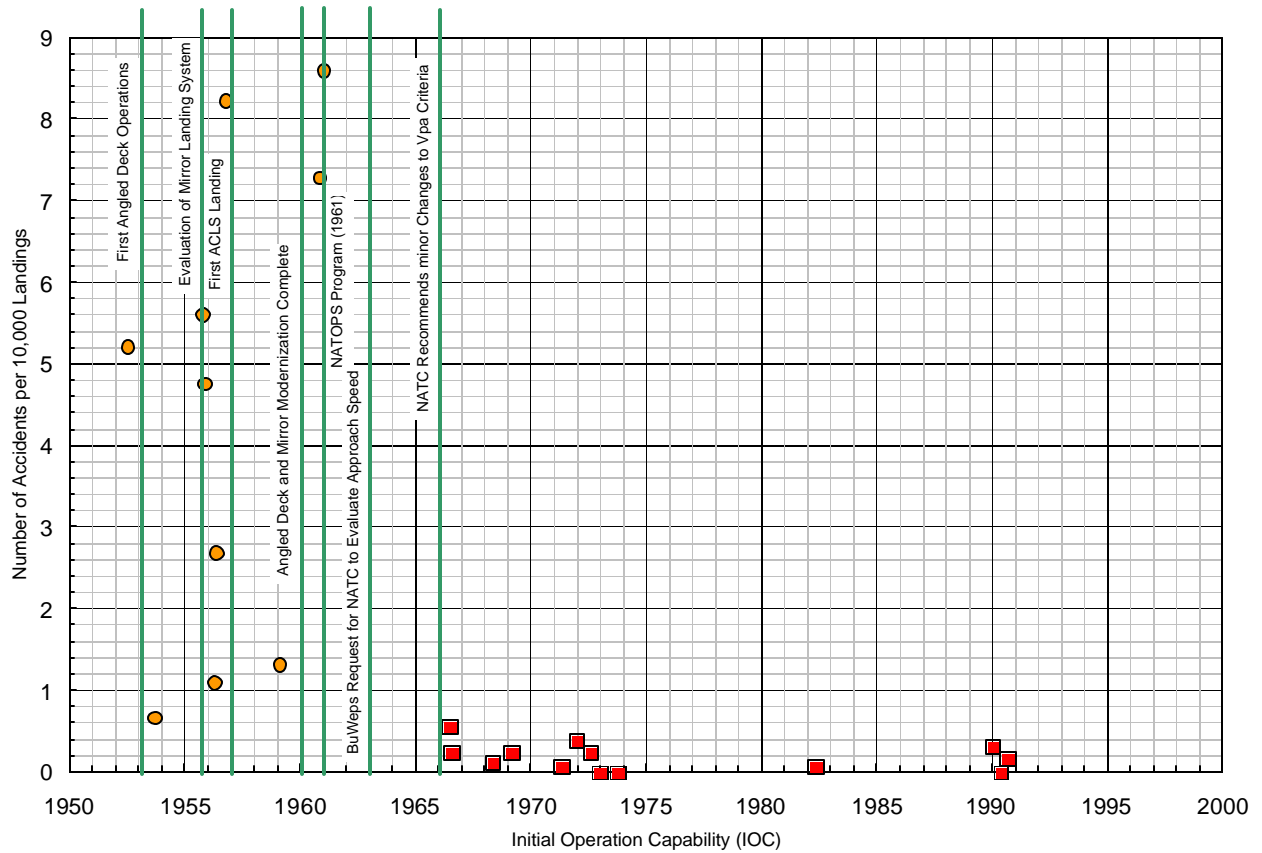

Figure 22: Historical Comparison of Mishap Rate and Key Milestones

CHAPTER 5: CARRIER APPROACH CRITERIA

5.1 GENERAL

This chapter explains the methodology used to calculate and validate the criterion and, where information is available, benchmarks current and legacy aircraft to the criterion. Calculations for these criteria are performed at a specified aircraft recovery weight. The recovery weight chosen is a design maximum CV landing weight based upon a standardized aircraft configuration. It is noted that, during development, the intended weight range for CV recovery must be assessed to ensure adequate FQ.

The JSSG, reference 1, specify that for all of the CAC, the aircraft is assumed to be in the landing configuration on a 4 deg GS with zero wind. Reference 1 also defines the atmospheric conditions of a tropical day (89.8°F). Tropical day is to be used in the calculation of the CAC based upon static C_L . Furthermore, the JSSG states that for aircraft with DLC, all V_{pa} criteria will be met with DLC engaged except for the FOV criterion, which will be met with DLC disengaged.

5.2 GLIDE SLOPE TRANSFER (POPUP) MANEUVER

5.2.1 DEFINITION

Reference 1 defines the GS transfer maneuver as:

“The lowest speed at which the aircraft is capable of making a glide path correction from stabilized flight to a new glide path 50 feet above the original glide path within five (5) seconds after initiation of the maneuver. The maneuver shall be performed without change in thrust settings by the pilot, and the aircraft AOA during the maneuver shall not exceed that necessary to achieve 50 percent of the maximum positive delta lift available, based on static lift coefficient, at the initiation of the maneuver. Control rate input for simulation of V_{PA} shall not exceed control system limits. The maneuver shall be considered complete when a glide path correction of 50 feet has been reached. After completion of this maneuver, the aircraft shall be capable of maintaining a new glide path at least 50 feet above and parallel to the initial glide path, with the pilot permitted to change thrust setting as required.”

5.2.2 METHODOLOGY

This criterion is often referred to as the 50 ft popup maneuver. The aircraft is to perform a GS maneuver so as to transfer from one GS to another GS which is 50 ft above and parallel to the initial GS. The maneuver must be completed within 5.0 sec. Longitudinal control can be applied as necessary with the constraint that the maximum incremental load factor cannot be greater than 50% of that available at the start of the maneuver. The throttle setting cannot be changed during the maneuver. This maneuver is often misunderstood to mean that the altitude of the aircraft is increased. In fact, the altitude at the end of the maneuver can be somewhat below that when initiated. For example, if the average sink speed of the aircraft is 15 fps during the maneuver, the aircraft will intercept the new GS 25 ft lower in altitude than when the GS transfer was started

(15 fps x 5 sec - 50 ft = 25 ft). The maneuver is complete when the aircraft intercepts the new GS. Figure 23 presents this maneuver, reference 51.

- 1) No Throttle Change
- 2) Not to exceed 50% available incremental load factor

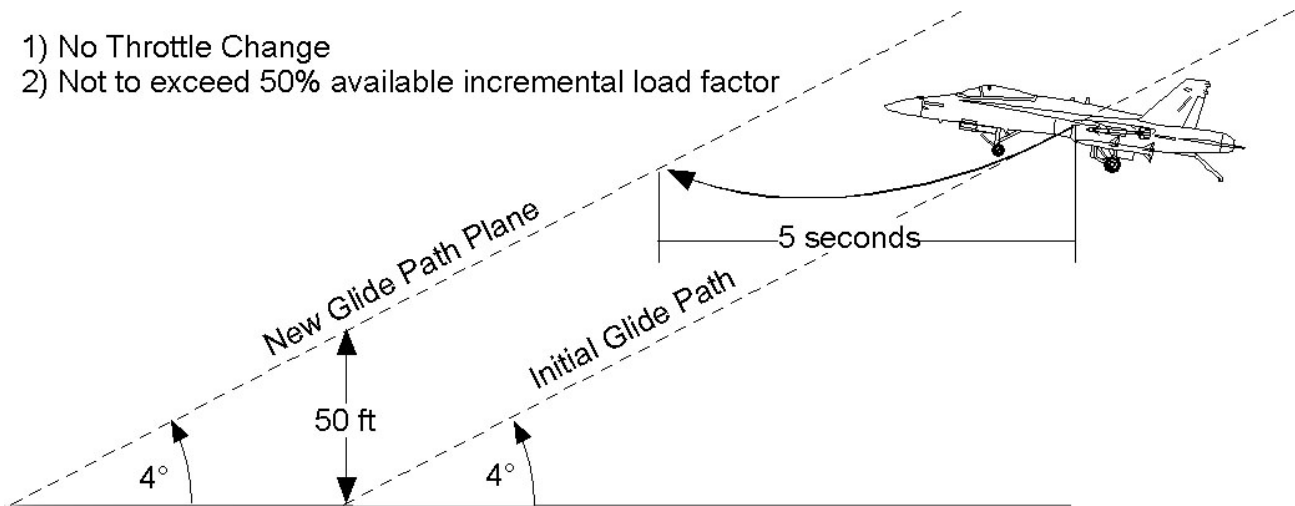

Figure 23: GS Transfer Maneuver

5.2.2.1 Simulation

The criterion is typically evaluated using nonpiloted simulation tools. The fidelity of simulation increases as the design matures through development. The government assesses risk through use of the criterion applying simplified 2DOF modeling, when appropriate. Differences between the government results and those obtained from the contractor are addressed. In preparation for flight tests of the GS transfer maneuver, it is strongly suggested that piloted simulation be conducted permitting the pilots to practice the maneuver.

5.2.2.2 Flight Test Validation

Prior to any high AOA testing within proximity to the ground, adequate high AOA testing must have been accomplished at altitude to clearly define flight characteristics at AOA's several degrees higher than the target AOA. Two portable FLOLS are positioned on the test runway 715 ft apart. Both are set to provide a 4 deg GS. Approaches are conducted using the first FLOLS. WOD should approximate that expected for shipboard recovery based on predicted V_{pa} and arresting gear limitations to minimize FPA variation effects. At the discretion of the pilot, longitudinal control input is made to achieve the desired maneuver AOA. The maneuver is complete after the pilot has passed a center ball on the second FLOLS or 5 sec after the initial longitudinal input, whichever occurs first. The test is to be conducted with no pilot throttle input. If provisions for the use of APC are authorized in the aircraft's specification, then tests should be repeated with the APC engaged.

Spatial data (altitude, sink speed, etc.) are obtained from the Automatic Laser Tracking System using retro-reflectors mounted on the aircraft. Corrections are applied from this location to the aircraft's CG. Vertical position of the aircraft relative to the original and second GS's and elapsed time from the initial longitudinal input are computed.

5.2.3 LEGACY AIRCRAFT CAPABILITY

The GS transfer characteristics of selected legacy aircraft are shown in figure 23. The calculations were performed using the NAVAIRSYSCOM 2-DOF performance simulation, reference 67, consistent with the JSSG methodology.

Table 6: GS Transfer (Popup) Performance of Legacy Aircraft (Analytical)

Aircraft	Comment	CG (%MAC)	Weight (lb)	Vpa (KTAS)	Popup (ft)
Meet Criterion					
A-3B		20.0%	50,000	135.8	68.5
A-6E		28.0%	38,000	129.2	82.3
A-6E		28.0%	36,000	125.8	81.5
EA-6B		28.0%	45,500	131.8	58
F/A-18A Interdiction (postflight test)	No Tanks	24.4%	30,500	142	77
F/A-18A Interdiction (preflight test)	No Tanks	24.4%	30,500	128.9	52.9
F-14A PA1 Configuration		16.2%	54,000	138	62.8
F-14D PA1 Configuration	DLC Engaged	16.2%	54,000	138.4	63.8
F-8J	BLC	30.0%	22,500	132.3	51.7
RA-5C		31.0%	50,000	140.5	58.7
T-45A	No Slat	25.0%	12,700	122.1	56.8
T-45A	Slat	20.0%	13,500	121.5	55.4
Do Not Meet Criterion					
F-4J		33.0%	40,000	145.6	49.1
F-14D PA2 Configuration		16.2%	54,000	132	46.4
F/A-18E/F Interdiction Return	Specification	25.0%	42,900	142	45.3
F/A-18E/F I Interdiction Return		25.0%	44,000	139.7	45
F/A-18A Interdiction (postflight test)	No Tanks	24.4%	30,500	128.8	41.9
F-111B		35.5%	56,000	112.2	39.8
F/A-18C Fighter Escort Configuration	No Tanks	25.0%	33,000	140.4	39.7
F/A-18E/F Fighter Escort Configuration		25.0%	44,000	137.8	38.7
F/A-18C Fighter Escort Configuration		25.0%	33,000	137.3	32.4
F-8C		30.0%	22,500	136.9	31.8

5.3 FIELD OF VIEW

5.3.1 DEFINITION

The FOV criterion is defined by the reference 1 as follows:

“The lowest level flight speed at which the pilot, at the design eye position, can see the stern of the carrier at the waterline when intercepting a 4 degree optical glide slope at an altitude of 600 feet. The origin of the glide slope is 500 feet forward of the stern and 63 feet above the waterline.”

Figure 24 illustrates the geometry of this criterion. Although the criterion places the origin of the GS at 63 ft above the waterline, the correct height of the GS source is 65 ft above the waterline, reference 68. Through analysis, it was determined that this difference is not significant to the result of AOA prediction using this criterion.

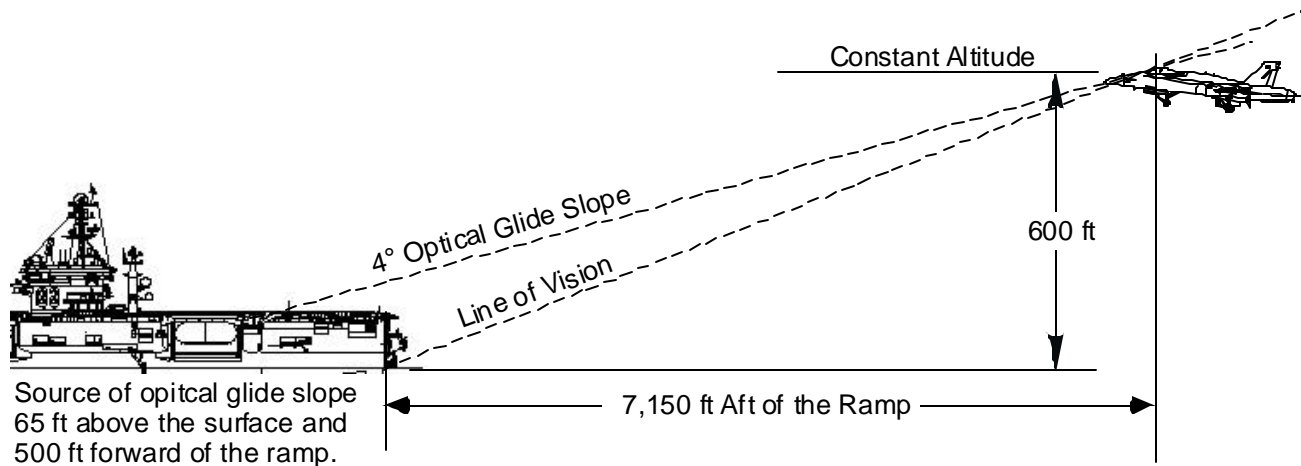

Figure 24: FOV Geometry

5.3.2 METHODOLOGY

The FOV criterion is based on a simple geometric relationship. The over-the-nose FOV is reduced by the angle formed by looking down at the CV waterline/stern intersection. For all aircraft on a 4 deg GS, this geometric look-down angle is 4.8 deg. Therefore, the maximum approach AOA allowed to meet the vision requirement is the FOV angle minus 4.8 deg. The geometry of the criterion places the aircraft 7,150 ft aft of the ship. The DEP is defined in accordance with reference 69.

5.3.2.1 SIMULATION

FOV is defined by analysis and is not evaluated in simulation.

5.3.2.2 Flight Test Validation

The criterion is satisfied if the geometry of the aircraft yields the required FOV for the intended approach AOA. The exact duplication of the FOV geometry can be obtained using a shore-based setup. However, due to the requirement for FLOLS ball acquisition at a distance of approximately 1 1/4 nm, absence of a clear definition of the FLOLS ball and other visual reference points can reduce test accuracy. The following reduced scale is suggested:

- a) The portable FLOLS should be positioned at the desired test site with a GS angle set at 4 deg. The height of the FLOLS center cell is 4.3 ft above the runway. A temporary runway marker is placed 536 ft prior to the FLOLS and perpendicular to the runway centerline. This marker can be a temporary highway lane marking strip.
- b) As part of the preflight checks, the pilot positions the seat vertically to obtain the DEP. References to locations in the cockpit are made.
- c) After takeoff and entering the VFR pattern, the pilot tracks the runway centerline using a constant altitude of 250 ft via the radar altimeter. The aircraft should be trimmed at the recommended approach AOA. The pilot should ensure location at the DEP. If a centered FLOLS ball is obtained prior to the temporary runway marker moving below the aircraft's nose, then the FOV has been met for the test AOA.

An alternative method can be conducted on the flight line, but requires exact determination of the aircraft's static pitch attitude and vertical distance of the DEP relative to the local surface. Using basic geometry and a required 4.8 deg lookdown angle below the zero pitch attitude, a reference mark on the surface of the flight line should be visible.

5.3.3 LEGACY AIRCRAFT CAPABILITY

A survey of USN aircraft from 1955 to 2000 shows that a majority of USN aircraft meet the FOV criterion as presented in table 7. It should be noted that some of the aircraft surveyed precede the FOV criterion. To satisfy the FOV criterion, the required FOV angle must be less than the approach AOA.

Table 7: FOV of Legacy Aircraft from Analysis

Aircraft	Comment	Available FOV At Level Attitude (deg)	Criterion Allowable AOA (deg)	Aircraft Approach AOA (deg (Units))	FOV Margin (deg)	Reference
Meet Criterion						
A-6E		19	14.2	10.3 (18)	3.9	70, 71
E-2C (-427)		16 (At Pilot Seat)	11.2	7.5 (20)	3.7	72
E-2C (-425)		16 (At Pilot Seat)	11.2	8.5 (20)	2.7	73
S-3		17	12.2	8.8 (15)	3.4	74
T-45	Slat	16	11.2	8.3 (17)	2.9	75
T-45	No Slat	16	11.2	7.0 (16.2)	4.2	76
EA-6B		20	15.2	12.6 (17)	2.6	77, 78
F-8H		12.5	7.7	5.4 (13.5)	2.3	79
C-2A(R)		17	12.2	10.3 (20)	1.9	80
F-14D PA1 Configuration		15.633	10.8	10.1 (15)	0.7	81
W2F-1		14 (Cockpit Centerline)	9.2	8.5 (20)	0.7	82
F-14A PA1 Configuration		15.633	10.8	10.2 (15)	0.6	83
F/A-18C/D		13	8.2	8.1	0.1	84
F/A-18E/F		13	8.2	8.1	0.1	85, 86
A-7A		16.65	11.9	11.9 (17.5)	0	87
A-7E		16.65	11.9	11.9 (17.5)	0	87
Do Not Meet Criterion						
TA-4		19	14.2	14.5 (17.5)	-0.3	88
F-8J		12.5	7.7	8.2 (13.5)	-0.5	89
T-2C		14	9.2	10.7 (15)	-1.5	90
F-4S		15.1	10.3	13.3 (19)	-3.0	91
F-4B/N		15.1	10.3	14.4 (18.3)	-4.1	92
RA-5C		9	4.2	9.7 (15)	-5.5	93

5.4 FLYING QUALITIES

5.4.1 GENERAL

Reference 1 defines the requirement for Level 1 FQ as:

“The lowest speed at which all stability and control requirements are satisfied (MIL-STD-1797).”

The term “Level 1” may have more than one meaning depending upon the context in which it is used. With regard to the discussion of analytical metrics, such as roll control and flightpath stability, Level 1 refers to the level of performance that historical or empirical data have suggested is required to achieve Level 1 FQ. The JSSG definition references MIL-STD-1797A, reference 37, as the authoritative guidebook for calculating these values.

The task of examining the definition, methodology, and legacy aircraft capability of each FQ criterion as set forth in MIL-STD-1797A, reference 37, is outside the scope of this study. It was decided that this investigation should concentrate on two reference 37 FQ criteria that directly relate to the CV approach task and have received considerable attention in the past: roll control and flightpath stability.

FQ are evaluated against the relevant military specifications. Wind tunnel testing is performed to generate static aerodynamic models for use in simulation analysis and design tools. FQ requirements are defined which are used to design and evaluate candidate control laws. Offline linear and nonlinear simulation is performed to validate FQ. As the design matures, higher fidelity data are collected for model construction and a full 6-DOF, nonlinear piloted simulation is used to tune the control laws and assess the FQ design prior to flight tests.

For a description of general FQ envelope expansion as well as Field Carrier Landing Practice (FCLP) evaluation, refer to reference 51. For specific flight test techniques of roll performance and flightpath stability is presented in the following section.

5.4.2 ROLL CONTROL

5.4.2.1 Definition

The criterion is defined as the speed at which a minimum bank angle change of 30 deg can be effected in 1.1 sec at a specified combination of weight and inertia. This criterion is an “open loop” FQ metric, meaning that the bank angle need not be captured, it simply must be satisfied within 1.1 sec for a full, abrupt lateral stick input. It is not only a measure of roll control power on the approach but is directly influenced by the roll mode time constant, control system latency, and indirectly by sideslip through dihedral effect.

5.4.2.2 Methodology

The roll control criterion is typically calculated by offline simulation. The analysis is performed for several configurations that may include variations in weight, inertia, and CG location to document and understand the sensitivity of these variables to the criterion. Vpa and approach AOA are determined using the CAC criteria. From a FQ perspective, the full range of operating approach GW must be assessed. For prediction of Vpa, the Carrier Landing Design Gross Weight (CLDGW) configuration is used to determine roll performance as a function of AOA (speed).

Roll performance can be estimated using a first-order transfer function given that the roll control power is known and an approximation can be made for the augmented roll damping term. This is a straight-forward application of a first order criterion to quickly and easily evaluate the roll performance potential of a configuration. Ganging control surfaces can easily be accomplished with little definition of the control system as long as realistic control surface deflections are used. Data Compendium methods, reference 94, can be used to estimate the bare airframe roll damping for initial roll performance estimates. The first order estimate of roll rate can be integrated to determine the bank angle change in 1.1 sec. As the design matures – preliminary control laws are defined, actuation system performance is postulated, weight and inertia characteristics are estimated, roll performance can be estimated from nonlinear 6-DOF simulation with all pertinent coupling effects included. This would provide the final basis for estimating the roll performance prior to flight test.

5.4.2.2.1 Piloted Simulation

The transition from a design that satisfies MIL-STD-1797A, reference 37, to a design that is satisfactory to the pilot is critical. Piloted simulation of specific approach tasks will be used to evaluate FQ during the CV approach and landing task, and changes to the airframe, control laws, or control scheduling may result. Additionally, piloted simulation provides important risk reduction for flight test. Emphasis is placed on the piloted simulation of the FQ, not adhering to an offline analytical criterion. Issues like roll command sensitivity have historically been difficult to evaluate accurately in the piloted simulation due to limited acceleration cues to the pilot. Motion base simulation brings the evaluator one step closer to representing the flight environment.

5.4.2.2.2 Flight Test Demonstration

Performance has historically been determined at the CLDGW that defines the maximum CV landing weight and corresponding store loading and roll inertia. Trimmed in a 30 deg AOB (or 1g wings level for analytical evaluation) at the CV approach AOA, the time-to-bank is measured during a full lateral stick input from a 30 deg AOB to a roll past 30 deg in the other direction. Excursions in AOA during the maneuver should be minimized (due to both change in control effectiveness with AOA but also changing speed) and the data should be reviewed to ensure minimal degradation in the quality of the response. The time-to-bank metric is extracted from the time history and is measured from the beginning of the lateral stick input until the bank angle has passed through 30 deg of bank angle change.

5.4.2.3 Legacy Aircraft Capability

Bank angle response in 1.1 sec was evaluated for several fleet aircraft using a 6-DOF simulation and their respective maximum recovery weight. The data from table 8 show that all surveyed aircraft met the criterion. It is important to note that the F/A-18E/F Super Hornet was designed to a 30 deg bank angle change in 1.0 sec, reference 95.

Table 8: Simulated Roll Performance for Several Fleet Aircraft

Aircraft	Weight (lb)	CG (% MAC)	Loading Loading	Altitude (ft)	Vpa (KTAS)	AOA (deg)	Bank Angle in 1.1 sec (deg)
Meet Criterion							
F-18E	44,000	28% MAC	Clean	500	133	8.1	35.0
F-14A (SAS On)	54,000		Clean	500	136	10.6	52.4
F-14D (SAS On)	54,000		Clean	500	136	10.4	50.0
EA-6B (SAS On)	45,500		Clean	1,000	132.6	12.5	36.1

5.4.3 FLIGHTPATH STABILITY

5.4.3.1 Definition

Flightpath stability was defined in Section 2.6.3.3. As airspeed is decreased, flightpath stability becomes unstable and the ratio $d\gamma/dV$ becomes positive. In the unstable region, the application of a positive pitch attitude control input will result in a steady-state decrease in the FPA. Aircraft that operate at a V_{pa} corresponding to positive $d\gamma/dV$ are said to be operating on the back-side of the power-required curve.

The flightpath stability criterion used to calculate an approach speed is found in the “Requirement Guidance” Section of MIL-STD-1797A, reference 37, paragraph 4.3.1.2, “steady-state flightpath response to attitude change.” The specification recommends values for the bounds on the amount of instability that can be accepted in the airframe to maintain a specified level of FQ. At the minimum V_{pa} [$V_{pa_{min}}$], the local slope of the FPA versus true airspeed curve shall be:

- $d\gamma/dV \leq 0.06$ deg/kt for Level 1
- $d\gamma/dV \leq 0.15$ deg/kt for Level 2,
- and $d\gamma/dV \leq 0.24$ deg/kt for Level 3.

The criterion further specifies that at 5 kt less than the minimum V_{pa} , the difference in slopes shall be ≤ 0.05 deg/kt as illustrated in figure 25. Because “the speed at which Level I FQ” is a determinant of V_{pa} , the lowest speed of $d\gamma/dV = 0.06$ deg/kt or the speed determined via the $V_{pa_{min}} - 5$ kts criterion will be the V_{pa} , if flightpath stability is the most limiting criterion.

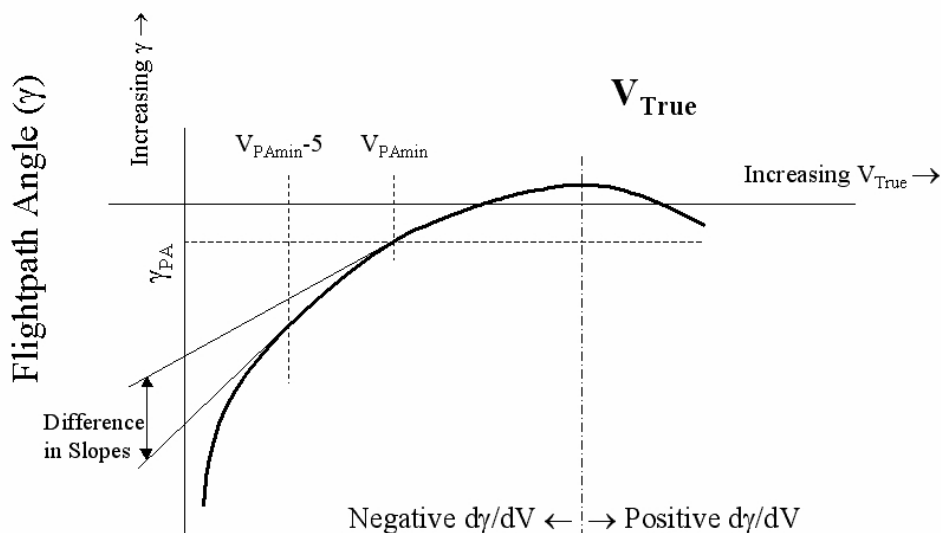

Figure 25: Flightpath Stability

5.4.3.2 Methodology

The flightpath stability criterion is typically estimated and evaluated using off-line static analysis based on aerodynamic data from wind tunnel tests. For all variants of the F-18 Hornet, flightpath stability was evaluated in flight test. The criterion assumes that the pilot intends to control flightpath vis-à-vis pitch attitude control. The specification assumes that the throttle setting is held constant during the maneuver.

5.4.3.2.1 Flight Test Demonstration

Flightpath stability is evaluated in flight test by stabilizing the aircraft at trimmed condition and then measuring the change in R/C or R/D as the airspeed is varied. Additional details of evaluating flightpath stability in flight are presented in reference 51.

5.4.3.3 Legacy Aircraft Capability

A flight test evaluation of flightpath stability occurred for the F/A-18A, reference 96, which was found to be Level I in all respects. In contrast, flight tests for the F/A-18E/F, reference 95, revealed that the aircraft met the Level I criterion at V_{pa}, but did not meet the Level I requirement at V_{pa}-5 kt. Nevertheless, because the flightpath stability characteristics were not objectionable to the pilots, the F/A-18E/F program decided not to increase the V_{pa} in order to satisfy the Level I FQ flightpath stability criterion at V_{pa}-5 kt.

Flightpath stability was calculated for seven USN aircraft, all which operate on the back-side of the power required curve. A simple 2-DOF linear model was implemented into MATLAB Simulink using a model based on Heffley’s work, reference 97. The results are shown in figure 26. The analysis was performed by commanding a 1-deg pitch attitude change at V_{pa}. Analysis was not performed for V_{pa}-5 kt.

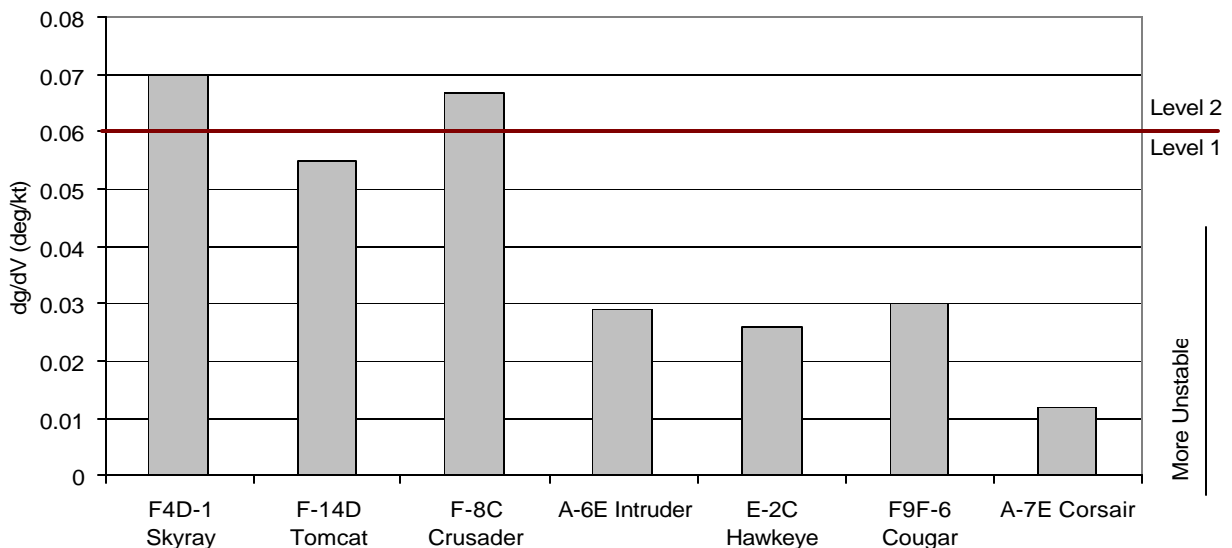

Figure 26: Flightpath Stability Characteristics of Selected Legacy Aircraft

The analysis showed that F4D-1 Skyray had the largest amount of flightpath instability, $dy/dV = 0.07$, which corresponds to Level II FQ.

5.5 STALL SPEED MARGIN

5.5.1 DEFINITION

The JSSG defines the power on stall speed margin criterion as:

“110 percent of the Power-On Stall Speed using the thrust necessary for level flight ($V_{s_{pa}}$) at 115 percent of V_{s_1} , the Power-Off Stall Speed in the landing configuration.”

5.5.2 METHODOLOGY

This analytical procedure is performed by determining the 1g trim speeds and thrust settings from stall to 115% stall for both power-on and power-off conditions. The trim speeds are surveyed for a standard day, sea-level condition. The thrust that coincides with the power-on speed that is equal to 115% of the power-off stall speed is the thrust value to use for the definition of the power-on stall speed. The power-on stall speed is then recalculated with this new power setting. V_{pa} must be greater than 110% of this revised power-on stall speed.

5.5.2.1 Piloted Simulation

Piloted simulation is not used to evaluate stall margin as specified by this criterion. However, piloted simulation may be useful in assessing FQ degradation near stall.

5.5.2.2 Flight Test Validation

This criterion was validated in flight test until the 1980's. References 98 through 101 contain examples of stall margin results of the A-6A, A-7E, F-4J, and S-3A.

5.5.3 LEGACY AIRCRAFT CAPABILITY

Analysis of the power on stall speeds of selected legacy aircraft are provided below in table 9.

Table 9: Stall Speed Margin of Selected Legacy Aircraft (Analytical)

Aircraft	Comments	CG (% Mac)	Weight (lb)	V _{PA} (KTAS)	1.1 V _{SPA} (KTAS)	Stall Margin (KTAS)
Meet Criterion						
F-8C		30.0%	22,500	136.9	133.1	3.8
F-8J	BLC	30.0%	22,500	132.3	122.4	9.9
A-3B		20.0%	50,000	135.8	119.9	15.9
F-111B		35.5%	56,000	112.2	105.7	6.5
F-4J		33.0%	40,000	145.6	132.7	12.9
A-6E		28.0%	36,000	125.8	103.7	22.1
A-6E		28.0%	38,000	129.2	106.6	22.6
EA-6B		28.0%	45,500	131.8	116.6	15.2
RA-5C		31.0%	50,000	140.5	123.5	17.0
F-14A PA1 Configuration		16.2%	54,000	138	120.9	17.1
F/A-18A Interdiction (preflight test)	Tanks Off	24.4%	30,500	128.9	112.2	16.7
F/A-18A Interdiction (postflight test)	Tanks Off	24.4%	30,500	142	118.2	23.8
F/A-18C Fighter Escort Configuration		25.0%	33,000	137.3	122.9	14.4
F/A-18C Fighter Escort Configuration	Tanks On	25.0%	33,000	140.4	122.4	18.0
F-14D PA2 Configuration		16.2%	54,000	132	120.8	11.2
F-14D PA1 Configuration		16.2%	54,000	138.4	120.9	17.5
T-45A	7.0 deg AOA No Slat	25.0%	12,700	122.1	110.9	11.2
T-45A	8.3 deg AOA Slat	20.0%	13,500	121.5	110.3	11.2
F/A-18E/F Fighter Escort Configuration		25.0%	44,000	137.8	123.6	14.2
F/A-18E/F Interdiction Return	Specification (Tropical Day)	25.0%	42,900	142	124.5	17.5
F/A-18E/F Interdiction Return		25.0%	44,000	139.7	122.5	17.2

No surveyed aircraft failed to meet the criterion.

5.6 FLIGHT CONTROL LIMIT SPEED

5.6.1 DEFINITION

The JSSG defines this criterion as:

“The minimum speed based on flight control limiting with margins applied as appropriate, subject to the approval of the procuring activity.”

5.6.2 METHODOLOGY

Wind tunnel data are used to determine critical CG locations and configurations where stability is low. For example, an AOA limit may be determined based on instability in the pitching moment versus AOA curve where nose-down control power is insufficient to recover from a gust of a specified magnitude. Additionally, the AOA at which closed-loop stability margins (e.g., standard gain and phase margins for a single-input, single-output linear control system) are not satisfied may be used to limit AOA. The practical implication of this criterion is that an AOA limiter may be

necessary in the powered approach configuration. The speed associated with the limit AOA, at CLDGW and aircraft loading, provides a lower bound on V_{pa} .

A locked-in stall point could be one example of a characteristic that early wind tunnel data and preliminary weight and balance estimates can predict accurately. In this scenario, the designer may choose to implement an AOA limiter (active flight control prevention of encountering the phenomena) in lieu of an aerodynamic change or an increase in control power. Degraded closed-loop FQ due to unsteady effects may not be represented accurately in the simulation and may not be evident until flight test. A software change (to limit AOA) could be necessary if the characteristic was clearly unsafe and there was a reasonable probability of encountering the condition operationally. Otherwise, a placard could be implemented to operationally prevent transgressions into that region of the envelope without any performance penalty.

5.6.2.1 Piloted Simulation

Piloted and offline simulation is important to verifying the FQ up to the FCLS is sufficient for the approach task. Robustness of the limiter will be evaluated to ensure the control system provides adequate protection from any unsafe characteristics. Typically, the need for an AOA limiter is established early in development based on analysis of the stability and control characteristics. Pilot opinion of controllability may, in some cases, be more limiting than that determined analytically.

5.6.2.2 Flight Test Validation

Flight tests will evaluate the mechanization and robustness of the limiter as well as determine the speeds for various GW's at the limit AOA for performance verification. FQ evaluations in flight will verify that the FQ up to the limit AOA is adequate for the carrier recovery task.

5.6.3 LEGACY AIRCRAFT

This criterion was adopted during the A-12 program and there have been no cases where V_{pa} was limited by an AOA limiter. In fact, no USN aircraft has required an active AOA limiter in the baseline power approach configuration control laws.

5.7 LONGITUDINAL ACCELERATION (LARGE THROTTLE RESPONSE)

5.7.1 DEFINITION

The longitudinal acceleration criterion, also called the large throttle response criterion, is defined in the reference 1 as:

“The lowest speed at which it is possible to achieve a level flight longitudinal acceleration of .155 g (5 ft/sec²) within 2.5 seconds after initiation of throttle movement and speed brake retraction.”

5.7.2 METHODOLOGY

The calculation is performed in a quasi-steady calculation where the aircraft is trimmed at the speed for approach AOA in level flight. The engine response is evaluated 2.5 sec later and the longitudinal acceleration is compared to the criterion. It should be noted that experience has shown that the transient performance of the engine is difficult to model.

5.7.2.1 Piloted Simulation

This criterion is not formally evaluated via piloted simulation. However, large throttle response is assessed qualitatively by the pilot in the waveoff task.

5.7.2.2 Flight Test Validation

This criterion is evaluated through level flight acceleration maneuvers. References 99 and 101 provide examples for the A-7E and S-3A aircraft, respectively.

5.7.3 LEGACY AIRCRAFT CAPABILITY

The large throttle acceleration capability of selected legacy aircraft is provided in table 10.

Table 10: Large Throttle Acceleration (Historical)

Aircraft	Report Number (Reference)	Approach Speed (KCAS)	Gross Weight (lb)
Meet Criterion			
A-7A		135	25,300
A-7E	FT-93R-70 (99)	140	27,500
A-6	FT2122-015R-63 (98)	122	36,000
F-14A	FT-09R-72 (102)	136	54,000
F/A-18A	SA-121R-82 (103)	139	33,000
TA-4	Note (2)	130	14,500
T-2	Note (2)	110	12,000
F-8		147	24,000
F-4B/N		139	38,000
ILE T-45	Note (2)	115.9	
F-14A+		136	54,000
F/A-18C			33,000
F/A-18E FE		139 Note (1)	42,900
F/A-18E INT		143 Note (1)	44,000
Do Not Meet Criterion			
F-111B	FT-04R-68 (104)	132	54,911
RA-5C	Note (3)		
T-45	Note (2)	115.9	11,600

- NOTES: (1) Tropical day.
 (2) Calculated using engine response measured data.
 (3) Under powered in PA configuration (reference 105)

The T-45A (no slat), F-111B, and the RA-5C were the only aircraft to not satisfy this criterion.

5.8 SMALL THROTTLE RESPONSE

5.8.1 DEFINITION

Reference 1 defines this criterion as:

“To ensure rapid aircraft response to step throttle commands corresponding to $\pm 0.120 g$ ($+3.86 ft/sec^2$) longitudinal acceleration, such throttle inputs shall result in achieving 90 percent of the commanded acceleration within 1.2 seconds. This requirement shall apply in the approach configuration throughout the range of all throttle settings required for operations over the usable approach configuration weight /drag levels while trimmed on a 4° glide slope.”

Figure 27 provides a graphic depicting the criterion and a representative time history satisfying the criterion.

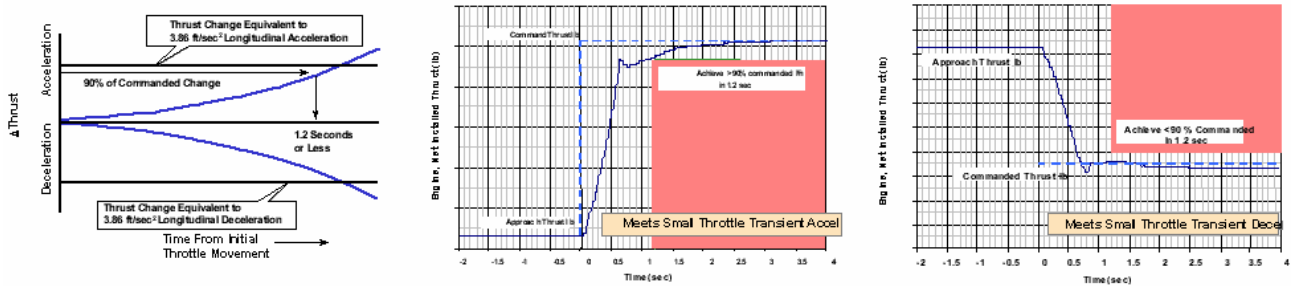

Figure 27: Small Throttle Transient Criterion

5.8.2 METHODOLOGY

The small throttle response is determined using a quasi-steady calculation in which the aircraft is trimmed statically at V_{pa} and aircraft longitudinal acceleration is computed over the time interval. The results are compared against the criterion.

5.8.2.1 Piloted Simulation

This criterion is not formally evaluated through piloted simulation. However, small throttle response is assessed qualitatively by the pilot during the CV approach task.

5.8.2.2 Flight Test Validation

Small throttle acceleration is evaluated during FQ evaluations of CV approach tasks.

5.8.3 LEGACY AIRCRAFT CAPABILITY

The small throttle criterion as defined was not a requirement until the late 1970's. Since that time, the F/A-18 model series and developmental aircraft that never made it to the fleet are the only ones that attempted to comply with this requirement. Calculations showed they could make the plus

requirement with margin but were challenged in achieving the negative requirement. The T-45 did not require this criterion but concentrated on improving engine response when using the expected small throttle movement positions during approach.

5.9 WAVEOFF

5.9.1 DEFINITION

Reference 1 defines waveoff as, “an aborted landing attempt during which the aircraft does not touchdown.” The ground rules provide the criterion basis for assessment and are found in Appendix B.

5.9.2 METHODOLOGY

There are two types of waveoffs described in reference 1, on-glide slope waveoffs and above-glide slope waveoffs. Refer to Appendix B for additional methodology detail.

5.9.2.1 Piloted Simulation

Piloted simulation is important to provide an early assessment of waveoff capability prior to flight test. Simulation is performed to gain pilot recommendations to changes in control laws or waveoff technique before flight test.

5.9.2.2 Flight Test Validation

It is essential that flight tests be conducted to quantify aircraft waveoff performance and determine the optimum pilot technique. This information is required for the normal recovery configuration(s) and all potential degraded modes, either airframe or engine related, for which CV recovery is possible. Waveoff testing requirements are addressed below with amplifying discussions in Section 6 of the Carrier Suitability Testing Manual, reference 51.

Reference 51 outlines test criteria used to validate the V_{pa} for waveoff. The test manual outlines two techniques for waveoffs from an onspeed, on-glide slope condition, namely: 1) maintain AOA throughout the maneuver and 2) rapid pitch rotation to a point where airspeed bleed-off occurs or controllability becomes a problem. Test results show that waveoff performance will be satisfactory if the following metrics are satisfied after initiation with a 0.7 sec pilot reaction time:

- a) An altitude loss not greater than 30 ft;
- b) A time to zero sink speed no greater than 3 sec with a longitudinal acceleration of 3 kt/sec on a 90 deg day; and
- c) A controllable aircraft rotation not greater than 3 deg aircraft nose up.

Experience has shown that a constant pitch waveoff is preferable to one that allows pitch rotation because it is easier to define and evaluate. Furthermore, a constant pitch waveoff reduces the potential for in-flight engagement (unintentional tailhook engagement with the CDP).

5.9.3 LEGACY AIRCRAFT CAPABILITY

Table 11 summarizes the waveoff performance of selected legacy aircraft based on a 2-DOF analysis using flight test validated databases. All calculations were performed at maximum recovery weight and corresponding V_{pa} , a 0.7 sec pilot reaction time, and tropical day.

Table 11: Waveoff Performance of Legacy Aircraft (Analysis)

Aircraft	Method	Optical GS (deg)	Approach Speed (KCAS)	WOD (kt)	FPA (deg)	Sink Speed (ft/sec)	AOA Change (deg)	Altitude Loss (ft)
F/A-18C	Note (1)	3.25	143	10	3.02	12.5	0	39
F/A-18C	Note (1)	3.5	143	0	3.50	14.5	0	48.5
F/A-18C	Note (1)	4.0	143	19	3.47	14.6	0	48
F/A-18E	Note (1)	3.25	142	10	3.02	12.5	0	37
F/A-18E	Note (1)	3.5	142	0	3.50	14.5	0	46
JSF (JMS)	Note (2)	4.0	140.0	17.0	3.51	14.5	0	48.5
JSF (JMS)	Note (2)	4.0	145.0	7.3	3.80	16.2	0	54

NOTES: (1) Used flight test validation database.

(2) JSF JMS evaluated at required carrier landing weight (based on F-18C performance).

In addition, a survey of flight test reports was conducted. Table 12 summarizes the waveoff performance of selected legacy aircraft. Test day conditions are assumed, however, some data may have been corrected to standard conditions.

Table 12: Waveoff Performance of Legacy Aircraft (Historical)

Aircraft	Report No. (Reference)	Optical GS (deg)	Sink Speed (ft/sec)	AOA Rotation	Altitude Loss (ft)
F-8J	FT-15R-69 (106)	3.5	12.5	1.5 units	37
F-8J	FT-15R-69 (106)	3.5	Note (1)	1.5 units	69
F-4J	FT-49R-68 (100)	Note (1)	12.5	Note (1)	24
A-7E	FT-93R-70 (99)	Note (1)	12.5	Note (1)	21
S-3A	LR 25100 (107)	3.5	10.5	0	19
S-3A	LR 25100 (107)	3.5	10.5	0	19
T-45A no slat	SA-80R-89 (108)	3.25	11.0	0	44
F-14A Plus	SA-127R-90 (109)	3.25	12.5	0	26
F-14A Plus	SA-127R-90 (109)	3.25	22.5	0	70
F/A-18A	SA-121R-82 (103)	3.5	14.6	0	42
F/A-18C EPE	SA-50R-92 (110)	3.5	12.1	0	29

NOTE: (1) Data not available.

The analytical and flight test results are illustrated in figure 28. Sink speed was used as the correlating parameter since it was available for most of the test data. Figure 28 illustrates the trend of increased hook altitude loss during waveoff with increasing sink speed.

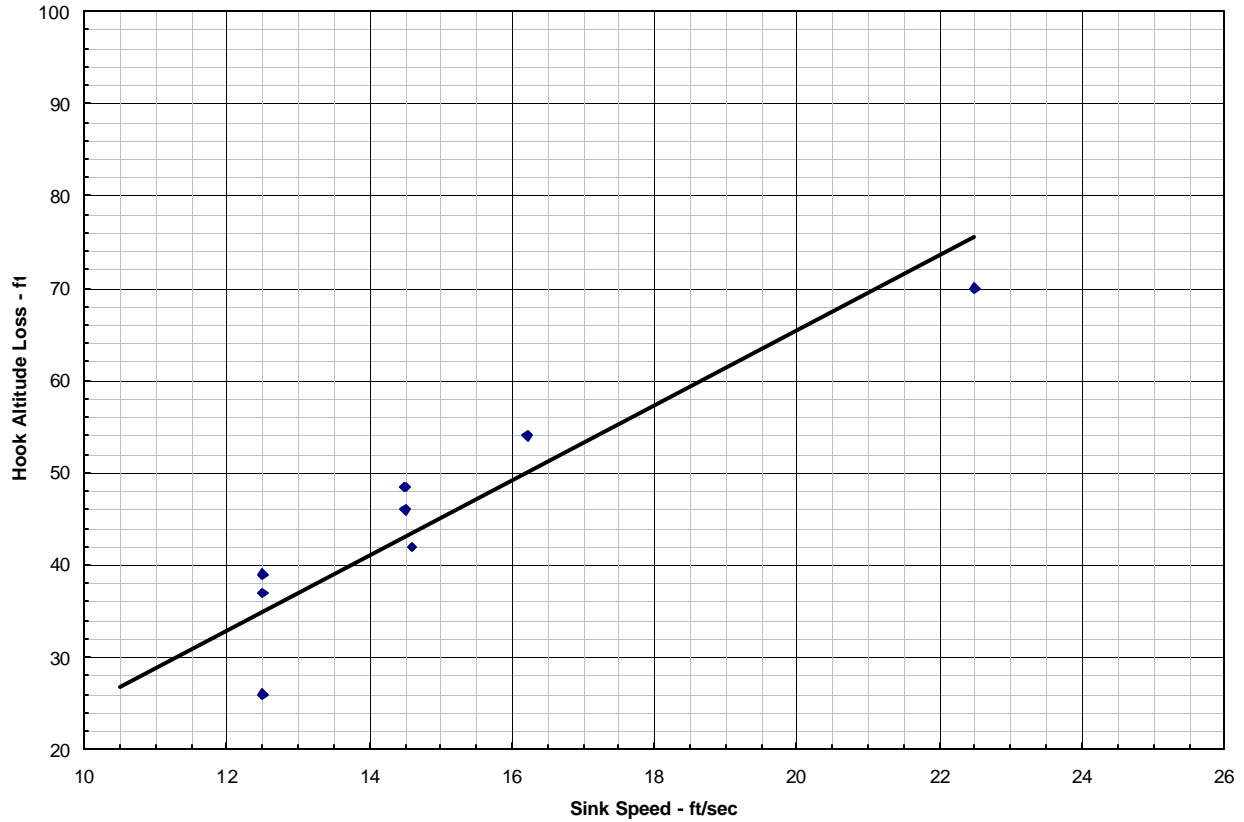

Figure 28: Hook Altitude Loss during Waveoff versus Sink Speed of Legacy Aircraft

In addition, review of waveoff test results and subsequent recommendations were conducted. The results of this investigation are listed in table 13. Where quantitative data were provided, they are presented.

Table 13: Flight Test Waveoff Performance Results (Historical)

Aircraft	Report (Reference)	Note(s)	Meet	Acceleration (ft/sec ²)		Waveoff Performance		
				Req'd	Flight Test	GS (deg)	Sink Speed (ft/sec)	Altitude Loss (ft)
Meet Criterion								
T2J-1	BIS 21226 (111)	Note (1)	Yes					
A-7E	FT-93R-70 (99)	Note (6)	Yes	4.5	9.8			
S-3A	LR 25100(107)	Note (7)	Yes			3.5	10.5	19
S-3A	LR 25100(107)	Note (8)	Yes					
S-3A	FT-74R-75 (101)	Note (9)	Yes	5.0	8.2			
F/A-18A	SA-121R-82 (103)	Note (10)	Yes			3.5	14.6	42
F/A-18A	SA-121R-82 (103)	Note (11)	Yes					
F-14A(Plus) – In Close	SA-127R-90 (109)	Note (12)	Yes			3.25	10-14	10-40
F-14A(Plus) – ¼ nmi	SA-127R-90 (109)	Note (12)	Yes			3.25	20-25	40-100
A-4M	FT-1R-71 (112)	Note (13)	Yes					
Do Not Meet Criterion								
RA-5C (with ECP-260a)	FT-139R-69 (105)	Note (2)	No			3.0	13.2	24.8
RA-5C (with ECP-260a)	FT-139R-69 (105)	Note (3)	No					50
F-111B	FT-04R-68 (104)	Note (4)	No					
F-8J	FT-15R-69 (106)	Note (5) Note (14)	No	3.0 kt/sec	3.16 kt/sec			
T-45A	SA-80R-89 (108)	Note (15)	No			3.25	11	44 avg 60 max
T-45A	SA-80R-89 (108)	Note (16)	No			3.25	~25	88

- NOTES: (1) The waveoff characteristics were considered satisfactory with the speed brakes open or closed.
- (2) The waveoff characteristics of the RA-5C aircraft are such that a large pitch rotation is required in order to achieve satisfactory waveoff performance. The requirement of having to rotate an aircraft to a high pitch attitude during a waveoff is an unacceptable technique for an "in-close" waveoff because of the danger of an in-flight engagement.
- (3) Unless a large pitch rotation is made during a RA-5C waveoff, an unsatisfactory altitude loss will result (approximately 50 ft), thereby giving the RA-5C aircraft an unsatisfactory "in-close" waveoff capability.
- (4) The F-111B, due primarily to its lack of adequate engine thrust response and great weight, exhibited unsatisfactory waveoff performance. The waveoff technique itself was unsatisfactory (a rapid rotation to 24 units) because it causes the aircraft's nose to block the pilot's view of the horizon and ship's island structure.
- (5) The waveoff performance of the F-8J is unsatisfactory, due primarily to limited excess thrust and the resulting large altitude loss after pilot waveoff initiation. The 3 kt/sec requirement is met at a GW of 22,000 lb on a standard day but seriously degraded performance is evident for GW's and temperatures representative of Fleet operating conditions.
- (6) It is noted that the acceleration requirement was 4.5 ft/sec² (test result 9.8 ft/sec²).
- (7) Waveoff data were obtained using a 3.5-deg GS angle and includes a reaction time of 0.7 sec for the pilot to react to a waveoff initiation by the LSO. Results of the waveoff tests for the worst case loading shows at 10.5 ft/sec sink speed the average altitude loss is 19 ft and average time to establish climb rate is 1.8 sec. Waveoff from flight idle power yielded altitude losses as much as 40 ft.
- (8) Care should be exercised by the pilot/LSO in assuring that waveoffs do not occur with the throttles at or near flight idle in conjunction with a high sink rate or a rising deck.

- (9) Waveoff acceleration capability was met by 63% (8.2 versus 5.0 ft/sec²) and stall margin was met by 7 kt (100.4 versus 93.6 kt).
- (10) For the normal approach configuration (full flaps), no improvement in waveoff capability is realized by aircraft rotation during waveoff. However, for the single engine recovery approach, a significant improvement in waveoff performance can be achieved by pilot rotation to 10.1 deg AOA (2-deg rotation).
- (11) During waveoff, if onspeed AOA was maintained, the aircraft had a very flat waveoff profile, requiring the LSO to move out his waveoff point.
- (12) Waveoff from nominal sink speeds (10 to 14 fps) resulted in altitude losses 10 to 40 ft. Waveoff from high sink speeds (20 to 25 fps) resulted in altitude losses ranging from 40 to 100 ft. Based on the criteria, with the normal PA(1) approach configuration, the LSO will be able to safely initiate waveoff from nominal approaches at a distance of 500 ft from the ramp. Waveoff from high sink speed can be safely conducted as close as 1/4 nm from the ramp.
- (13) Within the scope of this test, the waveoff performance was acceptable.
- (14) Within the scope of this test, the waveoff performance was acceptable.
- (15) The average altitude loss of 44 ft following waveoff initiated from nominal approach conditions did not meet the established test criteria for acceptable waveoff performance.
- (16) A time history of a waveoff initiated during a “high come down in close” GS correction where the power setting was below that required for stabilized flight is shown in enclosure (2). An altitude loss of 88 ft was experienced during this waveoff and would have resulted in a ramp strike or in-flight engagement if initiated during a carrier approach. The excessive altitude loss during waveoff requires the waveoff window to be moved out from the “in close” to the “in the middle” position (from approximately ¼ to ½ nmi) to ensure operational safety during the waveoff maneuver.

5.10 BOLTER

5.10.1 DEFINITION

A bolter is an unintentional shipboard touch-and-go landing. The term bolter performance is used to denote the distance from landing touchdown to liftoff from the CV. The reference 1 ground rules for calculating bolter performance are presented in Appendix B.

5.10.2 METHODOLOGY

A critical element of the required bolter performance is the amount of deck run available from the last CDP to the angle-deck round down. These distances are presented in table 14 for operational CV.

Table 14: Flight Deck Remaining from the Last CDP to Angled Deck Round-Down

Ship	Distance (ft)
KITTY HAWK Class CV-63 and CV-64	427
USS ENTERPRISE CVN-65	471
USS JOHN F. KENNEDY CV-67	468
NIMITZ Class (CVN-68 through CVN-75)	494
RONALD REAGAN CVN-76	507

Operational requirements dictate the distance used for the calculation. At the maximum recovery GW, its associated CG position, and the minimum required WOD for 1.05 times the V_{pa} , the arresting hook point is to pass above the last CDP. The V_{pa} used for this calculation is derived from the V_{pa} criteria.

The aircraft is placed on a 4-deg optical GS to generate a high sink rate. Thrust will be stabilized at flight idle to create the worst case for engine acceleration time. The throttles are advanced to military rated thrust (MIL) power 0.5 sec after main landing gear touchdown. Longitudinal control inputs are made 1.0 sec after touchdown to attain the desired fly-away attitude. The AOA should not exceed the approach AOA +3 deg and shall not be greater than $0.9 C_{Lmax}$. The bolter maneuver will be considered complete when the CG has achieved an altitude 50 ft above the flight deck.

With longitudinal control input as required to attain the desired fly-away attitude, all ground clearance margins as specified in the WSS shall be maintained. There should be no tendency for overrotation, underrotation, or pilot induced oscillation. Landing gear dynamics should not result in unacceptable pitch characteristics during the bolter. Level 1 FQ shall be maintained during all aspects of the bolter.

5.10.2.1 Piloted Simulation

Pilot-in-the-loop simulation is performed in evaluating bolter performance and FQ before beginning flight tests. Because landing gear dynamics play an important role in bolter performance, use of a high-fidelity landing gear model is warranted.

5.10.2.2 Flight Test Validation

The Carrier Suit Test Manual, reference 51, outlines testing criteria used to validate bolter performance. Two bolter scenarios are evaluated in flight tests to address operational considerations:

- a) Improper in-close thrust or pitch attitude inputs or excessively high on GS can result in the arresting hook point passing over the top of all the CDP's. This is the more critical condition in that the minimum flight deck is remaining to execute the bolter maneuver.
- b) The hook point landing within the desired location, but the hook point failing to engage a CDP due to: 1) hook point dynamics resulting in excessive hook bounce or lateral swing of the arresting hook shank preventing the hook point from engaging a CDP, or 2) improper tension on the CDP from the arresting engine allowing the CDP to be closer to the deck than desired, thus limiting the ability of the hook point to engage the CDP. In either case this type is commonly referred to as a "hook skip bolter".

Shore-based touch-and-go landings are conducted to determine bolter performance, characteristics, and desired pilot technique. Landing sink speeds at touchdown should be at least the mean carrier landing sink speed to ensure that aircraft pitch dynamics during the bolter are representative of a shipboard landing due to compression/extension dynamics of the main and nose landing gear. Flared landings will not produce realistic test conditions. Nonflared landings using a 3.5 deg GS are desired.

All normal and degraded configurations should be tested. The forward and aft CG positions can be critical because of the potential effect on nosewheel liftoff airspeeds at forward CG locations and adverse longitudinal characteristics at aft CG locations.

The recommended pilot technique during these tests should be application of MIL power at touchdown and longitudinal control input as necessary to achieve the desired flyaway attitude. However, the use of full aft control can produce undesirable overrotation tendencies. Other techniques should be considered if the characteristics of the aircraft warrant. Some pilot delay in throttle and control inputs should be expected.

The aircraft pitch characteristics during the shore-based bolter tests should be monitored. Landing gear dynamics can cause pitch oscillations (porpoising) during the bolter. In an extreme situation, the aircraft could be in a nose-down pitch cycle when the nose gear rolls off the angled deck, resulting in unacceptable aircraft characteristics and excessive sink.

Following shore-based buildup tests, shipboard tests are mandatory. Both normal and degraded configurations should be tested. The range of WOD to be used should be from the minimum RHW up to 40 kt, if achievable. Crosswinds components, both port and starboard, up to the aircraft limit should be investigated. Intentional landings beyond the CDP should be conducted to minimize deck remaining and time available to initiate bolter inputs, and also to evaluate rocking characteristics due to landing gear dynamics.

5.10.3 LEGACY AIRCRAFT CAPABILITY

Bolter performance of legacy aircraft was not available for this report. A cursory literature search revealed qualitative comments along the lines of bolter performance “was acceptable”.

5.11 FLIGHT TEST CONSIDERATIONS

5.11.1 APPROACH ANGLE OF ATTACK VALIDATION

5.11.1.1 General

This section discusses flight test requirements to assess the suitability of the recommended approach AOA and its associated airspeeds. These tests are for evaluation of the manual-landing task. Amplifying discussions regarding this and other ship suitability approach and landing issues, flight test methods pertaining to manual control with the APC engaged, and methods for ACLS tests can be found in reference 51.

Flight test is performed to evaluate the FQ and performance characteristics of the aircraft on the GS and during the bolter and waveoff maneuvers. The result of the tests is the establishment of the procedures, pilot techniques, and the Vpa/AOA to be used during CV recovery operations. Flight tests are also performed to determine the feasibility of recovering the aircraft aboard the CV under abnormal or degraded conditions (e.g., partial/no flaps, single engine, degraded flight control configurations, etc.). The data obtained are used for the preparation of the ARB's and is also included in the NATOPS Flight Manual.

Many factors must be considered relating to the evaluation of the recommended approach AOA and the associated airspeeds for the range of recovery GW's. It is desired that the slowest possible approach AOA and airspeed be defined in order to minimize recovery WOD requirements. However, the need to establish the slowest AOA must be weighed against the requirement to ensure adequate FQ and performance to safely perform the CV landing task.

5.11.1.2 Shore-Based Buildup and Shipboard Tests

5.11.1.2.1 Approach Airspeeds with Gross Weight and Configuration

The purpose of this test procedure is to establish the associated Vpa at the recommended CV approach AOA for all possible shipboard recovery configurations. A variety of flight test maneuvers are conducted at CV approach conditions at altitude prior to simulated CV landings. It is essential that airspeed and AOA system calibrations be conducted. A recent weight and balance is also required. The following procedures and variables should be evaluated and the associated test procedures are described in reference 51.

- a) All tests should be conducted at a pressure altitude descending from 5,000 to 3,000 ft or at a minimum altitude consistent with safety requirements.
- b) The aircraft should be stabilized at a R/D corresponding to a -3.5 deg FPA. It is essential that this condition be satisfied because an aircraft will be at a higher airspeed for any given approach AOA in a R/D than it would be if the test were conducted at a level flight condition. This is due to a combination of two factors: 1) reduced vertical component of thrust due to reduced thrust in a R/D and 2) reduced lift due to propulsion effects.
- c) All anticipated recovery configurations, including emergency, should be tested. The recommended procedure is during the descent from 5,000 to 3,000 ft, reconfigure the aircraft through the various normal and emergency configurations at the associated CV approach AOA. This will enable data collection over a desired GW range.
- d) The GW range should vary from approximately 5% above the maximum CV landing GW to the lowest fuel state consistent with the minimum "on deck" requirements. GW increments should be approximately 1% of the maximum carrier landing gross weight.
- e) The effect of CG position on the Vpa must be determined. Short-coupled aircraft are quite sensitive to trimmed lift variations due to CG position.
- f) The effects of wing-mounted stores should be determined. Vpa variations will occur due to wing/store interference. Wingtip mounted stores, e.g., F/A-18, effects should be quantified.
- g) Off nominal approach AOA tests should be conducted. AOA up to 2 deg higher and lower than the recommended AOA should be conducted.

Final recommendations for the CV approach AOA used for preparation of the ARB should reflect the loadings and CG positions which result in the highest airspeeds for each configuration. However, the effects of variables such as wing-mounted stores and CG position must be included so that operational commanders can assess these factors and modify recovery WOD requirements if needed.

5.11.1.3 Degraded Configurations

The feasibility of recovering an aircraft aboard the CV under degraded conditions should be investigated. The following emergency conditions may be applicable, depending on the aircraft design:

- a) No DLC. This is required only if DLC is an integrated part of the longitudinal control system; otherwise nonDLC configurations should be evaluated as part of the basic approach configurations tested.
- b) Nonstandard high lift configurations such as partial or no flaps, slats, etc.

- c) Single engine or degraded digital engine control modes. Single engine approaches can be very critical from a waveoff and bolter standpoint and the use of reduced flap settings should be investigated.
- d) For aircraft incorporating an arrestment thrust limiting system, arresting gear compatibility tests with the system disengaged are required.
- e) Degraded digital flight control modes.

The optimum AOA over the GW range for which landings are feasible, pilot technique and H/E distance for the degraded configurations must be determined. Maximum landing GW may have to be reduced to permit recovery within achievable WOD. Some degraded configurations may require an approach at a different AOA than normally prescribed. The possibility of a nosewheel first landing and/or bolter should be examined closely. Clearance of an emergency configuration for shipboard recovery must also be based on satisfactory waveoff performance and the ability of the pilot to cope with the turbulence aft of the carrier (burble).

The demands placed on a pilot compensating for a degraded situation requires comment. For normal recovery, the aircraft handling qualities should place minimal demands on the pilot. It is not reasonable to expect this to be the case for degraded situations. The demands placed on a pilot, however, should not result in less than Level II Cooper-Harper Rating (CHR) for the CV landing task, reference 113.

Crosswinds during degraded recovery operations are not normally recommended; however, it is necessary to evaluate the criticality of each degraded configuration to crosswind operations and test appropriately. It is not practical to dictate zero crosswind recovery and, therefore, it is necessary for the test team to conduct shore-based testing, followed by at-sea testing, to define a limited crosswind recovery envelope.

5.11.2 SHIPBOARD TESTING CONSIDERATIONS

Shipboard tests are mandatory since the shipboard environment cannot be duplicated ashore. To obtain maximum utilization of the available CV deck time, all approach evaluation programs must be preceded by a comprehensive shore-based evaluation and maximum use of touch-and-go landings when shipboard.

The applicability of shore-based test results to shipboard conditions must be thoroughly investigated under various WOD conditions. The turbulence aft of a CV increases as the WOD increases. Special pilot techniques may be required at the higher WOD conditions because of more severe airflow disturbances. The effect of various WOD conditions on landing parameters, such as sinking speed, attitudes, touchdown dispersion, bolter rate, etc. can be significant. The lowest WOD investigated should be based on aircraft structural and arresting gear capacity considerations. A WOD of 45 kt is considered an upper limit. The effect of turbulence at the higher WOD conditions on GS tracking, and waveoff and bolter performance should be determined by varying the WOD in increments of 5 kt both above and below the normal 25 kt WOD condition.

Crosswind limits for the aircraft should not be investigated until zero-crosswind testing is complete. For a starboard crosswind component, the island-induced turbulence will move forward in the landing area as the WOD decreases. The magnitude of the crosswind should be increased gradually because of the airflow discontinuity and potential for aircraft control problems encountered close to the ship. A crosswind component limit of 7 kt applies to all ships.

Night approach and landing tests, which are required to the suitability of the cockpit and external lighting systems, should not be investigated until all critical requisite tests under day conditions have been completed. There have been cases where certain aircraft characteristics were satisfactory under day test conditions but were unacceptable for night operations.

CHAPTER 6: ASSESSMENT OF CARRIER APPROACH CRITERIA

6.1 GENERAL

The results of the approach task decomposition provided added confidence that a critical review of the CAC criteria alone was sufficient to highlight any criteria deficiencies and ensure all tasks and elements of the carrier environment were properly considered. While it was the task decomposition effort that strongly supported adoption of a task-based evaluation strategy, no new conclusions regarding the criteria weaknesses were generated separately from the task decomposition. In an indirect way, the task decomposition effort led to the adoption of a criteria relevancy/adequacy analysis process that critically assessed the criteria relative to the approach task.

In this section, two questions are asked with respect to the criterion. First, “Is the criterion relevant to the approach task?” Second, “Is the criterion adequate to assess the approach task?” In selected cases, piloted simulation was performed to further the understanding of the criterion. Each of the criteria were rated using the descriptions of relevancy in table 15 and adequacy in table 16.

Table 15: Criterion Relevancy Definitions

Relevant – This criterion is directly relatable to the approach task. The ground rules in the criterion are representative of conditions normally encountered during CV approach. The criterion is consistent with available technology and applies to all classes of aircraft. Criterion directly relates to safe and efficient CV recovery.
Marginal – Questionable importance to the CV approach task. Ground rules may not be representative of typical CV approach conditions.
Irrelevant – Evidence exists that the criterion is inconsistent with the operational CV approach task. Criterion provides no clear traceability to safe and efficient CV recovery.

Table 16: Criterion Adequacy Definitions

Adequate – Success thresholds in the criterion are consistent with analytical predictions, simulation, and flight test results. Fleet experience supports the thresholds in the criterion. The criterion has proven itself a reliable design metric as a predictor of Vpa.
Marginal – Success thresholds are questionable and may not be consistent with legacy capability. Criterion should be loosely applied to the prediction of Vpa.
Inadequate – Success thresholds are unfounded or conflict with fleet experience. Any criterion rated as irrelevant is, by default, inadequate. Criterion not applicable to the prediction of Vpa.

Although somewhat subjective, the ratings were derived through team discussion. It is important to clarify the context of the relevancy and adequacy assessments. Relevancy of a criterion is assessed only in reference to the approach task. It should be thought of in terms of: is the criterion consistent with how the aircraft is operated in the approach environment? Adequacy, on the other hand, is assessed relative to the prediction of Vpa and its consistency relative to historical or analytical test results. Relevancy is a consistency/validity check on the criterion while adequacy is a verification of the acceptability thresholds and its feasibility to predicting Vpa. Some criterion may be based on

solid analytical data yet still be a poor predictor or invalid criterion for Vpa. The results of this analysis are summarized in table 17.

Table 17: CAC Relevancy and Adequacy Ratings

Approach Speed Criterion	Relevance	Adequacy
GS Transfer (Popup) Maneuver	Irrelevant	Inadequate
FOV	Relevant	Adequate
Level I FQ	Relevant	Marginal
Roll Control	Relevant	Marginal
Flightpath Stability	Marginal	Inadequate
Stall Speed Margin	Marginal	Inadequate
FCLS	Marginal	Marginal
Large Throttle Response (Longitudinal Acceleration)	Relevant	Marginal
Small Throttle Response	Relevant	Inadequate
Waveoff	Relevant	Marginal
Bolter	Relevant	Marginal

6.2 GLIDE SLOPE TRANSFER (POPUP) MANEUVER

6.2.1 RELEVANCE

The GS transfer (popup) criterion was rated as irrelevant to the CV approach task as defined in reference 1.

The popup criterion is not directly relatable to the approach task. The criterion attempts to ensure a minimum level of aircraft aerodynamic capability based on a maneuver that is not representative of the approach task. While it is logical that some minimum aerodynamic capability exists to augment the thrust-to-flightpath aircraft response, it is unrealistic to assume that the stick is the primary (and only) flightpath inceptor for CV operations using back-side technique. The aerodynamic response is dominated by the load factor capability of the aircraft and the margin to stall. The predominant factors in the thrust-to-flightpath response are the engine dynamic response and the thrust inclination angle. As discussed in Chapter 4, there is a balance between the required thrust-to-flightpath performance and the required AOA-to-flightpath capability. The pilot will control flightpath with the throttle, but will augment the flightpath response in the short-term by introducing a pitch attitude (AOA) change. The time constant associated with flightpath response to a thrust input is long in comparison and, therefore, the back-side control strategy is necessary to optimize the aircraft response to a GS error. Once the new flightpath is achieved, the aircraft returns to onspeed as the aircraft responds to the thrust change. Therefore, while it is true that some minimum level of aerodynamic capability is required to perform a GS transfer, the flightpath change need not be accomplished only through aircraft aerodynamic response.

Additionally, the ground rules of this criterion are not representative of conditions normally encountered during CV approach. This criterion assumes no throttle inputs to control flightpath. Because Naval Aviators are trained to use back-side technique on CV approach, the throttle is the primary inceptor for flightpath control. Thus, the ground rule is in conflict with normal approach control strategy.

The reference 1 definition of the criterion is also inconsistent with available technology. The criterion was developed before the advent of IFPC systems. Available technology allows for robust APC systems to be deployed as the primary control mode of the aircraft during the landing phase. The reference 1 criterion does not take this into account. Moreover, the reference 2 form of the criterion makes provisions for the use of APC in the popup calculation.

Finally, this criterion does not directly relate to the safe and efficient recovery of aircraft. While designers have suggested that the popup calculation may have been useful as a wing sizing tool, the popup maneuver as defined (e.g., no throttle change) is not used in the Fleet to enhance aircraft recovery.

The notion of excess load factor capability for both escape maneuvers (waveoff) and GS tracking is a valid consideration. It has been pointed out that the GS transfer maneuver is not representative of a GS correction or tracking task but it is also not very meaningful for an escape maneuver as well, where thrust will be applied to increase energy. Although it is clear that some minimum aerodynamic capability is required, the GS transfer criterion is not a meaningful methodology to provide such capability. A new criterion is required that addresses not only aerodynamic load factor capability for GS tracking but also considers the natural tradeoff with thrust-to-flightpath response. Thoughts for developing a new criterion, namely a short-term flightpath criterion, is discussed further in Chapter 7.

6.2.2 ADEQUACY

The GS transfer criterion was rated as inadequate as a metric to ensure adequate GS tracking characteristics and prediction of V_{pa} . A criterion that is irrelevant to the carrier approach task is by definition an inadequate criterion in the determination of V_{pa} . While accurate GS control characteristics are relevant to the carrier approach task, the implementation of the GS transfer maneuver is inconsistent with typical CV recoveries.

The analytical basis for the thresholds in the criterion is unclear. Section 2.5.4.1 indicated that the choice of "one-half (1/2) of the incremental load factor" was derived from pilot opinion, not data analysis. Follow-on analysis has shown that the primary determinant of a successful GS transfer in 5 sec is the airspeed margin from stall (or minimum speed). Reference 97 shows that other design factors play an insignificant role in the determination of popup performance. Since stall margin is a separate V_{pa} criteria and the maneuver defined is not indicative of CV recoveries, the popup criterion is not adequate for the prediction of V_{pa} . Furthermore, fleet experience does not support the thresholds in the criterion since the 50 ft in 5 sec threshold is inconsistent with fleet experience. The performance of legacy aircraft against the popup criterion is presented in Section 5.2.3 which provides evidence that not satisfying the popup criterion does not exclude the aircraft from achieving satisfactory GS tracking during a CV approach. This is evidenced through reference 39 shows that

LSO's consider the F/A-18C to possess excellent GS tracking characteristics. An additional survey of LSO's from all air wings conducted as part of this investigation, reference 65 confirmed this finding. However, table 6 shows that the F/A-18C does not satisfy the popup criterion.

Finally, the fact that the fleet has deployed several aircraft that do not meet the popup criterion is an indicator of the inadequacy of the criterion. Table 6 shows that several fleet aircraft, including the most recent addition to the fleet, the F/A-18E/F Super Hornet, do not satisfy this criterion. Therefore, the GS transfer (popup) criterion is inadequate to predict Vpa and is unable to predict GS tracking ability.

6.2.3 INVESTIGATIVE EFFORT

Because of the highly questionable nature of the adequacy and relevancy of the popup criterion, an investigation was launched to further investigate flightpath response. Heffley points to the need for investigation in RHE-NAV-90-1, reference 97, "If the popup maneuver is intended to ensure an effective lower limit on short-term flightpath response, then it should be modified using a metric that directly reflects short-term flightpath response or control bandwidth explicitly."

In the existing array of carrier approach design criteria, there has not been an explicit requirement for a minimum level of short-term flightpath response. That is, there is no criterion that provides a direct minimum level on how aggressively the pilot can track the GS. Some existing criteria such as the popup maneuver, flightpath stability ($d\gamma/dV$), and indirectly the small throttle response, appear to address flightpath control, but none set an explicit level of short-term response that would dictate a minimum control bandwidth appropriate to the task. Reference 37 allows for specification of a flightpath response, but no value is presently defined or recommended.

One problem that a short-term flightpath response criterion would address is the ability to make sufficiently rapid corrections in GS error within the limits inherent to the final approach to the carrier as shown in figure 29. Useful FLOLS guidance begins at a range of approximately $\frac{3}{4}$ nm from the carrier. All path corrections must be successfully completed and a steady state achieved no closer that about 1,000 ft from touchdown. This crucial task requirement lacks any explicit requirement of aircraft performance or maneuverability.

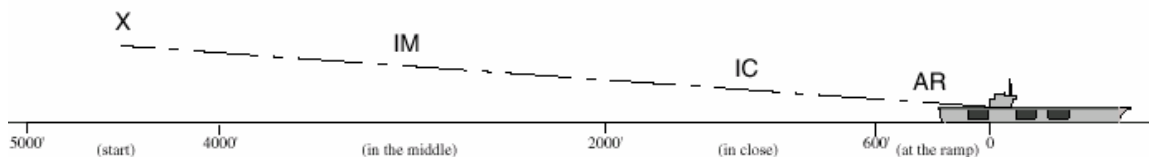

Figure 29: Profile of the Carrier Approach Task

An investigative effort was performed that provides a systematic examination of candidate metrics and criteria, Appendix C. While there are several design features that contribute to short-term flightpath control, some have greater importance than others and some are already addressed by existing design criteria. For example, there is a FQ criterion for short-term response of small amplitude longitudinal acceleration. This impacts thrust response, one possible component of flightpath response. But thrust response alone may not guarantee a satisfactory level of flightpath

response. Some experimental data are presented in reference 114 and a detailed analytical treatment is given in reference 97. These sources give a basis for selecting the most influential parameters with respect to short-term flightpath control.

6.2.4 SUMMARY

Based on this study, it is concluded that the GS transfer (popup) criterion is irrelevant and inadequate as a metric in the prediction of Vpa. It is recommended that the popup maneuver not be used in the prediction of Vpa. Development of a short-term flightpath response criterion that addresses both aerodynamic and propulsion system performance is recommended to address the GS tracking task for both full up and degraded modes. Characterization of required performance for an escape task, like the waveoff, is better suited in a waveoff criterion.

6.3 FIELD OF VIEW

6.3.1 RELEVANCE

The FOV criterion is relevant to the CV approach task.

The pilot depends on visual cues such as the FLOLS and the droplights to perform the approach task. Should the pilot's FOV be such that information from these cues is not available, performance will be degraded in VFR conditions. With the advent of advanced pilot cueing systems, the relevancy of the FOV criterion has been brought into question. However, until these systems can be demonstrated to be extremely reliable, a FOV criterion is needed.

The reference 1 criterion is based on the FOV from the pilot's DEP to the ship's waterline. Fleet experience shows that pilots will normally take advantage of any practical means of improving their FOV, typically by raising the seat as high as possible, and by craning the neck. While anecdotal, this information shows that FOV is very important to the approach task.

Furthermore, experimental data obtained in this study underscores the importance of a criterion that guarantees adequate FOV. Due to the significant impact this criterion has on limiting approach AOA, an investigative effort was initiated to investigate the FOV criterion. Appendix D contains a description of the tests and presents the results. Within the scope of the effort, the results indicate that pilots consider FOV to be relevant to safe and efficient recovery.

6.3.2 ADEQUACY

The FOV criterion is adequate to predict Vpa. Fleet experience supports the thresholds in the criterion. An analysis of the fleet aircraft, Section 5.3.3, shows that the approach AOA for the A-7 and all variants of the F-18 were constrained by the FOV criteria. Furthermore, the data and historical documentation indicate that few aircraft violate the thresholds associated with this criterion. This does not necessarily show that the existing criterion establishes an absolute minimum, but provides additional ancillary evidence that the criterion is consistent with the operational need. Questions have arisen regarding the logic behind a 4 deg GS instead of 3.5 deg and the need to see

the waterline at the intersection of the GS. Experimental results discussed in the following section indicate that FOV provided by the 4 deg GS ground rule is adequate for safe and efficient recovery.

6.3.3 INVESTIGATIVE EFFORT

A series of FOV experiments was performed at Virginia Tech using the research flight simulator. FOV was restricted using cardboard templates placed in the optics of the simulator visual system. FOV restriction was varied in increments from the FOV that just satisfies the current criterion. Pilots performed Case III approaches under IMC to VMC conditions under a solid overcast. The approaches were straight-in from 6 nmi, 1,200 ft MSL. The Instrument Landing System (ILS) needles and the APC datum were varied to cause the pilots to break out in off-nominal conditions that could be any combination of left/on/right, high/on/low, or fast/on/slow. Upon acquiring visual contact with the ship, the task commenced. The pilot attempted to correct GS, lineup, and airspeed as required to complete a successful landing. Pilots assessed the safety and suitability of performing the task with the various FOV's presented.

In two separate experiments, the pilots unanimously felt that the FOV available using the current criterion was adequate and safe. In the first experiment, the four participating pilots felt that 2 deg less FOV was a marginal case. Additional tests showed that 2 deg were unsatisfactory under critical conditions. Critical conditions were low and slow starts, lined up either left or right. These conditions caused the pilots to lose sight of the landing area when performing corrections.

A second experiment was conducted to refine the pilots' opinions of the adequacy of the FOV in the range from 1 to 2 deg more restrictive than the criterion permitted. Based on this experiment two pilots felt that there could be room for as much as 1 deg relaxation in the criterion, while the other two felt that no relaxation was possible.

6.3.4 SUMMARY

It is concluded that the FOV criterion as defined in reference 1 is a relevant and adequate metric for the prediction of V_{pa}. Experimental results suggest a relaxation of up to 1 deg FOV may be possible. No significant revisions of the FOV criterion are required. Limited reductions of less than 1 deg of the criterion threshold may be explored.

6.4 FLYING QUALITIES

6.4.1 GENERAL

6.4.1.1 Relevance

The Level 1 FQ criterion is relevant to the CV approach task.

Level 1 FQ directly relates to the approach task, and is critical to the safe and efficient recovery. The pilot control problem of minimizing error on GS, lineup, and speed is related to the aircraft's ability to change trajectory when commanded. The back-side control strategy for flightpath and the importance of a satisfactory thrust response was previously described in Chapter 4. Requirements for

satisfactory pitch and bank attitude control are evident. Satisfactory pitch response is necessary to augment flightpath control and crisp and precise bank attitude control is required for lateral offset corrections. The reference 37 definition of Level 1 FQ provides a minimum level of maneuverability and trajectory control for the carrier approach task, but does not inherently guarantee satisfactory mission performance. While unsatisfactory FQ characteristics identified at Vpa will likely result in a redesign effort, the option exists for the designer to increase the Vpa to improve the FQ. While the redesign alternative is less likely for modern tactical aircraft (where great flexibility exists to tailor the aircraft response), it is for these reasons that FQ remains a relevant design aspect to the prediction of Vpa.

6.4.1.2 Adequacy

The adequacy of the Level 1 FQ criterion is rated as marginal. There is some question as to whether the reference 1 criterion represents the most reliable metrics to predict the closed-loop FQ to identify potential issues or risks. Initially, the aircraft designer uses traditional design metrics (i.e., MIL-STD-1797A, reference 37) such as short period frequency and damping, time to bank, and dutch roll frequency and damping (classical aircraft response design metrics) to perform a preliminary design of the control layout and size control powers and rates. Candidate control laws are developed to evaluate the viability of the design and early piloted simulation evaluations. However, as the design and configuration matures, less reliance is placed on traditional design metrics and more emphasis is placed on the closed-loop piloted simulation. It should be recognized that fixed-base piloted simulation has limitations (limited motion cues, excessive visual system delays) that should be considered as part of the confidence placed in the piloted simulation results.

The classical design metrics can be very helpful diagnosing/troubleshooting problems and issues that get identified in the simulation. Furthermore, computer automated tools for analytical evaluation of FQ metrics across a wide range of the envelope and for a range of aircraft loadings can be performed to gain valuable insight into sensitivities and trends without exhaustive, expensive piloted simulation evaluations. It is cost and time prohibitive to evaluate the hundreds or thousands of test points possible in the piloted simulation. Therefore, it is concluded that a combined comprehensive analytical and limited piloted evaluation effort is the most efficient process for identifying FQ risks. Issues found in the analytical evaluation can be assessed in the piloted simulation to fully understand the closed-loop performance impact. Motion-based simulators should be pursued when comprehensive formal evaluations are to be performed.

In principle, operational envelopes are typically not cleared based on analysis, but analytical evaluation does mitigate risk, show sensitivities, and can guide flight test or piloted simulation test point selection to test only the critical regions of the fight envelope and critical loadings (CG, lateral asymmetry, etc.).

While both the designer and the acquisition community can use these classical design metrics to identify risk, their value as hard and fast requirements is questionable. Maximum flexibility should be the goal, as piloted evaluation of the closed-loop system should take precedence over design metrics. Design metrics are based on historical data where, in most cases, the aircraft was designed to operate in a classical sense. This restricts innovation as the aircraft response is designed to behave like previous aircraft instead of developing a response that ultimately will improve task performance

or reduce pilot workload. The fact that reliable design metrics do not lend themselves to advanced flight control modes must not discourage the designer from pursuing new approaches to old problems. The emphasis, early in the design, should be on generating sufficient control power and response bandwidth required for the task. Furthermore, because advanced control modes are susceptible to latency and time delays, reliable design metrics are needed to evaluate their impact to closed-loop response.

Any FQ criterion as applied to the CV landing must accomplish the following:

- a) Guarantee satisfactory FQ and trajectory maneuverability at the defined V_{pa} for the critical loading.
- b) Ensure that the task can be performed.
- c) Ensure graceful degradation at lower speeds.
- d) Certify robustness to degraded environmental conditions: winds, turbulence, gusts, sea state, etc.
- e) Assure that the aircraft can land safely aboard the ship for all first failures and second failures that are not remote.

Therefore, because the reference 1 criterion cannot perform all of these functions, it is concluded that V_{pa} not be determined solely on the reference 1 criteria unless more detailed information is not available.

6.4.2 ROLL CONTROL

6.4.2.1 Relevance

A roll response criterion is relevant as it directly relates to the lineup element of the CV approach task.

6.4.2.2 Adequacy

The roll control criterion is rated as marginal to predict V_{pa} . It directly impacts the ability of the pilot to tilt the lift vector to execute a lateral or lineup correction. Additional factors like roll bandwidth and/or equivalent/effective roll time delay, and roll/yaw coupling may be as important in determining a desired set of lateral dynamics for the CV approach task. The 30 deg bank angle change in 1.1 sec is supported by considerable historical flight data. As stated in Section 5.4.2, most legacy Naval aircraft satisfy the criterion at the approach speed/AOA. Lateral/directional FQ issues have historically been a result of unsatisfactory roll/yaw coupling or excessive adverse yaw.

However, it is recommended that the roll control criterion should not be applied in a manner that would limit V_{pa} if sufficient piloted simulation data supports the lower level of roll performance. Due to the difficulty of accurately assessing roll dynamics in a fixed-base simulation, it is recommended that a high fidelity motion-base simulation be used to make this assessment.

While the reference 1 roll control criterion is based on sound experimental data, recent simulation studies have suggested that other metrics may be more reliable FOM's. Therefore, additional experimentation is recommended to investigate effective roll time delay (measured from the nonlinear time history response) or roll bandwidth as potential FOM's.

6.4.2.3 Investigative Effort

Recent simulation studies have raised questions regarding the connection between roll performance and recovery FQ. A joint McDonnell-Douglas Aircraft (MDA) Corporation/Navy piloted simulation effort, reference 115, examined various levels of roll performance during simulated carrier landings with a 1-cosine shaped roll rate gust and showed no correlation between pilot ratings and roll performance. In this scenario, pilots were more sensitive to stick gradient and roll mode. One could argue that with digital flight controls gross corrections are not required since deviations from the optimum trajectory are less likely due to lower workload and improved aircraft response. However, low time pilots who are unlikely to have extensive mastery of the aircraft must be considered. In addition, a critical scenario is rarely discussed: recoveries in blue water, at night, and rough seas. A pilot may only conduct 10% of his landings in this environment, but this may place significant demands on the pilot and aircraft system. Investigation into nonlinear effects like added phase delay as well as variations in roll-sideslip coupling is warranted.

Airplanes with significant adverse yaw often require some augmentation to keep the sideslip generated during rolls to acceptable levels. Not only do the adverse yaw effects reduce roll performance (through stable dihedral) but use of rudders and differential horizontal tail to control sideslip can reduce the available rolling moment as well. Digital flight controls can essentially program a wide range of adverse or proverse yaw during rolls. Naval pilots have become accustomed to flying feet-on-the-floor during the approach. Recent simulation experience on the F-14D has suggested that a small amount of adverse yaw is beneficial to the pilot. This finding is consistent with pilot expectations and eases the workload on the rollout at the desired heading. Complex elaborate control laws are not required to achieve acceptable sideslip response to rolls and can usually be accomplished with fairly direct techniques like aileron-to-rudder interconnects.

6.4.3 FLIGHTPATH STABILITY

6.4.3.1 Relevance

The relevance of the reference 1 flightpath stability criterion is rated as marginal to the CV approach task. While flightpath stability relates directly to the task, the ground rules of the criterion are not typical of a CV recovery.

6.4.3.2 Adequacy

The flightpath stability criterion is inadequate to predict V_{pa} .

While flightpath stability is important to how the pilot operates the aircraft, numerous sources have documented that operation on the back-side (unstable flightpath stability) in and of itself is not a factor in determining V_{pa} . The criterion does not adequately address operation on the back-side, with throttle as the primary controller for flightpath. Many Naval aircraft operate on the back-side due to the low required V_{pa} for CV approaches.

The flightpath stability specification has been critically reviewed as inadequate to describe flightpath stability for the carrier approach task by several respected sources. STI, reference 116, challenged the criterion on two fundamental grounds. First, if front-side technique is being used, then some parameter other than flightpath stability may be more critical at certain flight conditions. Second, different pilot techniques are used depending on the characteristic of the flightpath stability. Smith and Geddes, reference 117, have pointed out that,

“the dg/dV specification may not adequately encompass the range of pilot techniques for glide slope control. Throttle, in general, is an important flightpath control. Navy doctrine, in fact, requires that the principal glide slope control cue for carrier-approach.”

Since the 1950's, Navy pilots have landed carrier-based aircraft using back-side technique, discussed previously in this report. MIL-STD-1797A, reference 37, provides an exception for aircraft that do not use pitch attitude control as the primary controller of flightpath,

“...a relaxation is warranted when use of such a piloting technique is deemed acceptable. Examples might be some shipboard and STOL operations. In those cases the pilots must be trained appropriately.”

Fleet experience does not support the thresholds in the criterion. Four F-4 Phantom variants provide interesting insights into the value of the criterion for aircraft that operate using back-side technique. Smith and Geddes, reference 117, observed that the F-4B/M airframes and the F-4J/K airframes shared the same flightpath stability characteristics but were equipped with different engines as shown in table 18. The turbojet engines provided the pilot with improved engine response, while the turbofans were less responsive. For the case of the F-4B/M airframe, although the flightpath stability characteristics were Level I, the engine responsiveness had a decisive impact on the pilot opinion. The F-4 also exhibits a relatively large thrust incidence angle, which improves the flightpath response to throttle. This may partially explain the pilot comments for the F-4. It also highlights the criticality of engine response when used as the primary controller for flightpath. This finding indicates that flightpath stability in and of itself is not an adequate FOM for longitudinal FQ on approach.

Table 18: Flightpath Stability Characteristics of Four F-4 Variants

Airframe	V _{PAmin} (kt)	d γ /dV (deg/kt) at V _{PAmin}	d γ /dV (deg/kt) at V _{PAmin} -5 kt	Pilot Rating*	Engine
F-4B	138	-0.01 (Level 1)	0.01 (Level 1)	Mid Level 1	J79 Turbojet
F-4M	138	-0.01 (Level 1)	0.01 (Level 1)	Low Level 2	Spey Turbofan
F-4J	132	0.07 (Level 2)	0.10 (Level 2)	Mid Level 2	J79 Turbojet
F-4K	132	0.07 (Level 2)	0.10 (Level 2)	Low Level 2	Spey Turbofan

*Pilot ratings based on Cooper-Harper Handling Qualities Scale.

Furthermore, empirical data indicate the F4D-1 was not Level 1 in flightpath stability. A 1986 study of the F4D-1 flight characteristics, reference 118, revealed that “despite the fact that approach speeds occurred in the ‘reverse command’ region, and despite the poor lateral-directional characteristics, the pilots considered the approach characteristics satisfactory, because the aircraft responded well to throttle and longitudinal control inputs . . . Longitudinal flightpath control in the approach did not appear to be a problem for the F4D-1 aircraft.”

A linear analysis of F4D-1 flightpath stability was performed as part of this investigation. Figure 30 shows the response of the F4D-1 to a pitch attitude input. The analysis indicates that 18 sec elapsed between the initiation of pitch attitude input and the time at which FPA began to move in the opposite sense to the pilot command. Thus, the flightpath-to-stick time constant is relatively long compared to time constants associated with the short-period dynamics of the aircraft, perhaps explaining why longitudinal flightpath control was not found to be deficient by the pilots.

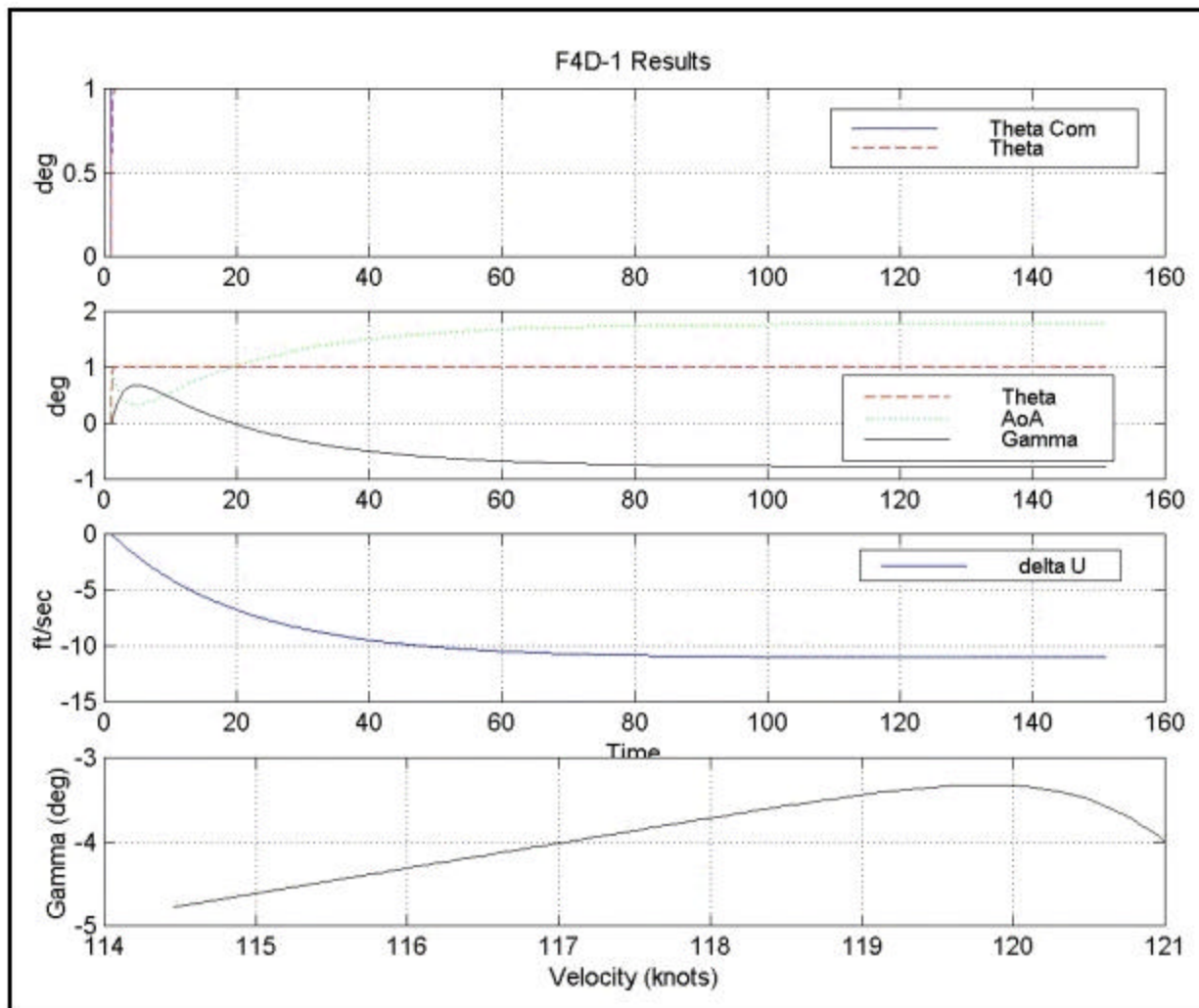

Figure 30: F4D-1 Flightpath Stability Analysis Results

Gerken, reference 119, in developing FQ criteria for a proposed U.S. Air Force Short Takeoff and Landing (STOL) Transport, considered the levels of flightpath stability necessary to describe the FQ of an aircraft flown using back-side technique. The report found that, “When a primary controller other than the longitudinal column is used to effect a rapid change in flightpath, the local slope at V_{0min} shall be negative or less positive than . . . Level 1: 0.20 degrees/knot . . . Levels 2 and 3: 0.35 degrees/knot.” The recommended relaxation of the FQ levels from that of the reference 1 criterion was based on prototype flight test results and simulation studies. The study also recommended that the $V_{0min} - 5$ kt criterion be retained for aircraft not using the longitudinal column as the primary controller. Smith and Geddes, reference 117, recommended that a time-to-arrest sink rate criterion be developed as an alternative to the existing flightpath stability criterion.

6.4.4 SUMMARY

Satisfactory FQ are relevant to safe and efficient recovery. It is concluded that the reference 1 FQ criterion has value as a preliminary design metric, but may not be adequate to determine V_{pa} as written. Task-based evaluation augmented with analysis may be an alternative method to demonstrate satisfactory FQ. Generally, the FQ will improve with increasing V_{pa} so increased V_{pa} is a possible solution to FQ issues. Advances in high-fidelity simulation provide the opportunity to assess pilot opinion of FQ early in the design cycle.

6.5 STALL SPEED MARGIN

6.5.1 RELEVANCE

The stall margin criterion was rated as marginal in its relevance to the CV approach task. With modern aircraft, stall margin will seldom play a significant role in the definition of V_{pa} . It is more pertinent to Class II or Class III aircraft configurations that may not be dominated by leading edge extension (LEX)/forebody vortex lift at high AOA.

Historically, aircraft stall has been accompanied by undesirable handling characteristics including buffet and lateral/directional stability issues. LEX forebodies have extended the maximum lift coefficient to much higher AOA than traditional wing-lift dominated designs. The stall AOA is typically far beyond the approach AOA and has not been a factor in recent Naval aircraft. However, even if the FQ are sufficient past stall, performance considerations will necessitate some margin relative to stall when operating at or near V_{pa} .

6.5.2 ADEQUACY

The stall margin criterion was rated as inadequate for the prediction of V_{pa} .

The stall margin definition provided in the V_{pa} criterion is difficult to justify. The definition relies on determining the thrust for level flight at 115% of the stall speed in the landing configuration to determine the power-on stall speed. While power-on stall speed is more representative of the in-flight condition, it makes more sense to define stall with the power required for level flight at V_{pa} . One could argue that the more critical condition is the power required on GS (which would increase stall speed and thus V_{pa} , since power is lower) but stall speed testing is normally conducted in level-flight conditions. On the back-side, the thrust at the 115% stall speed condition will be lower than the thrust at stall. Therefore, setting this power setting and evaluating stall will result in a higher stall speed. This appears to be a conservative approach. No substantial rationale was discovered supporting the more complex approach. Ignoring the distinction between V_{SL} and $V_{S_{pa}}$, which should be insignificant, a simpler calculation approach is desired. The basic concept of maintaining a minimum margin relative to stall is considered sound and should be continued even if it is meaningful only for Class II or Class III aircraft.

6.5.3 SUMMARY

The stall margin criterion is evaluated to be marginally relevant but inadequate. The stall margin criterion, while supported by historical data, is not directly pertinent to advanced tactical aircraft with significant vortex lift, which extends the stall AOA considerably beyond any typical approach AOA. A simpler, easier definition of power-on stall is necessary. Power-on stall speed in 1g flight should be predicted for the mission loading associated with the Vpa definition. Vpa must be higher than the 10% margin on the stall speed. In accordance with MIL-STD-1797, reference 37, other factors (lateral/directional issues, unacceptable buffet, etc.) may determine stall speed instead of maximum lift. In these cases, the calculation procedure and the margins should be the same.

6.6 FLIGHT CONTROL LIMIT SPEED

6.6.1 RELEVANCE

The FCLS criterion is rated as having marginal relevance to the CV approach task for configurations that require an active control limiter (e.g., an AOA limiter). For those designs and concepts that do not employ a flight control limiter, the classical stall margin criterion would instead apply.

The designer must provide a safe envelope for the aircraft to maneuver on GS. Because piloted simulation would very quickly identify any unreasonable constraints on this capability, the need for a criterion may be debatable. It is also unlikely that this criterion would effect the definition of Vpa. If an AOA limiter was in proximity of the approach AOA, the pilot community would find this unacceptable and a redesign would be required. Full-time APC systems further make this criterion of limited value since these systems would work to minimize speed variations and, as a result, excursions to higher AOA would be more unlikely. Catapult launch operations, typically conducted in configurations similar to approach and landing (other than GW) will require rotation to an AOA beyond those encountered on approach. This is required to achieve low WOD for catapult launch at heavy GW's. Since operation at higher AOA will be required for catapult launch, unreasonable constraints on AOA will not be permissible. Therefore, this criterion has marginal relevance for prediction of Vpa.

6.6.2 ADEQUACY

The adequacy of the FCLS criterion is rated as marginal relative to the prediction of Vpa.

Some margin relative to the limiting AOA or airspeed would be required for normal maneuvering on GS. A margin of at least 5% at the speed corresponding to the limiting AOA is appropriate for maneuver margin. The limiting speed corresponds to the speed at the limiting AOA for the loading identified for Vpa prediction. The acceptability of the margin must be evaluated by the pilot community in a variety of environmental conditions to ensure sufficient maneuvering margin exists. Since margins will be designed into the AOA limiter, it is the intent to minimize the margin relative to Vpa to that required for maneuvering.

6.6.3 SUMMARY

The FCLS criterion is rated marginal in both relevance and adequacy. It is recommended that the definition of the rationale and criterion used to define the mechanization of the limiter be coordinated with the procuring activity to ensure sufficient margins exist.

6.7 LONGITUDINAL ACCELERATION (LARGE THROTTLE RESPONSE)

6.7.1 RELEVANCE

The large throttle response criterion is relevant to the CV approach task.

The rate at which MIL thrust level is achieved is dependent on the level of trim-thrust required for approach. The trend towards aerodynamically clean aircraft to improve range and endurance have the negative consequence of reducing the trim power required on approach. Techniques have been employed to move the trim approach throttle setting away from idle by deploying drag devices like speed brakes. A rapid change in thrust can enable smaller changes by other control parameters to correct a situation, or vice versa. Airframe designers work very closely with engine designers to maximize throttle response for powered approach to improve waveoff performance and GS tracking tasks. The large throttle response is consistent with an “escape” maneuver on approach like a waveoff where full dry power is commanded to accelerate and generate a positive R/C in a quick manner.

6.7.2 ADEQUACY

The adequacy of the large throttle criterion is marginal in the prediction of V_{pa} .

Since 1967, a number of evaluations have confirmed the large throttle response criterion value of 5.0 ft/sec² in 2.5 sec for longitudinal acceleration as a minimum desired (see Section 2.6.6.1). Experience with the T-45 aircraft confirmed this value as an adequate benchmark. Waveoff performance is the operational task that this criterion most directly impacts. Sections 2.6.6.1 and 5.9 previously discussed the inconsistencies between large throttle response and the waveoff criteria. In addition, the large throttle response does not consider other factors like reconfiguring the aircraft that might be used to improve waveoff performance (stowing drag devices, rotating to a higher AOA, etc.). Therefore, in spite of the supporting data of the desirability of the large throttle response it makes more sense to define a minimum threshold for waveoff performance to provide the designer with maximum design flexibility.

While it is clear that the large throttle response criterion applies more to an escape type maneuver than a GS tracking task, a criterion of this form should be maintained as an initial design metric for excess thrust and thrust transient performance for initial engine sizing. Waveoff, while operationally meaningful, does not lend itself to being a useful metric for engine sizing in the early stages of the design. The large throttle response criterion needs to be consistent with any updates applied to the waveoff criterion.

6.7.3 SUMMARY

The large throttle response criterion was evaluated to be relevant to the approach task but marginal in its application for the prediction of Vpa. Waveoff performance is the preferred FOM in addressing the desired escape maneuver performance. However, it is recognized that the large throttle response criterion could be very useful as an engine sizing design metric. While the large throttle response remains a useful tool for evaluating the engine response and resulting aircraft acceleration as part of design trades, it should not be used for formally predicting Vpa.

6.8 SMALL THROTTLE RESPONSE

6.8.1 RELEVANCE

The small throttle response criterion is relevant to the CV approach task.

Because most, if not all, carrier-based aircraft operate on the back-side during the approach and the fact that Naval pilots are trained to use throttle to control flightpath, the throttle is continuously modulated during the approach task, whether that movement is pilot controlled or automatic. It is the only criterion requiring a minimum level of performance from the engine. Fleet experience has shown that decelerating commands are as important for GS control as accelerating commands. This criterion can have a significant impact on the trim throttle setting as it becomes more difficult to satisfy this criterion the closer the trim throttle is to idle. Ultimately, a short-term flightpath control criterion is necessary to address both the propulsive and aerodynamic aspects of flightpath management.

6.8.2 ADEQUACY

The adequacy of the small throttle criterion to define desirable GS tracking characteristics and to determine Vpa is rated as inadequate.

The aircraft's quick response to small throttle commands on the GS is one of the most desired features for excellent approach characteristics (substantiation for this is provided in Section 2.6.6.2). The reference 1 criterion of 90% of $\pm 3.86 \text{ f/sec}^2$ commanded acceleration within 1.2 sec originated in the mid-70's for the F-18A specification. A throttle-to-thrust bandwidth or throttle-to-flightpath bandwidth criteria would likely be better suited for driving the flightpath response requirements for back-side operation. As stated above, some minimum level of performance is required for both throttle advances and throttle chops.

6.8.3 SUMMARY

The small throttle response criterion is relevant but inadequate in predicting Vpa. It is recognized that it is unlikely this criterion will be a significant factor in predicting Vpa due to the interrelationship complexity between airframe and powerplant is not available early enough in the development cycle. However, short-term flightpath control is such an integral player in the approach task, it is important that airframe and engine manufacturers have an adequate criterion for their system design. The engine designer first tries to achieve the best engine response possible. After

this, most often, the aircraft manufacturer design solution to improve small throttle response is to move the trim throttle higher on the thrust response curve by increasing drag. This results in more fuel usage in the landing pattern. It is important to develop an adequate small throttle response criterion that will assure good approach characteristics and can be used for V_{pa} prediction. Development of such a criterion is addressed in Chapter 7.

6.9 WAVEOFF

6.9.1 RELEVANCE

The waveoff criterion was rated as relevant to the CV approach task.

Waveoffs are executed routinely in carrier recovery operations due to the deck going foul or the approaching aircraft being outside the LSO's acceptable approach thresholds. Waveoff has not historically been a driver in predicting V_{pa} but waveoff performance is a direct fallout of V_{pa} with WOD used only when required to meet other constraints (arresting gear limits, hookload limits, etc.). Acceptable waveoff capability ensures the pilot can safely escape from a situation where the aircraft is below GS with too much sink rate to be able to recapture the GS for a safe arrestment. In other words, the pilot needs to be able to arrest the sink rate before losing too much altitude so he/she can safely clear the ship without compromising controllability. Therefore, waveoff criteria must ensure sufficient excess power capability within the constraints of visibility and aircraft handling qualities. In defining these criteria, it is reasonable to assume that the pilot will use both throttle and stick to maximize the chance for success. Operational considerations, like in-flight engagement potential, must take precedence in establishing the optimum waveoff technique. It is also prudent to assume that this is the case when designing the aircraft to ensure as large a design space as possible in seeking a cost-effective solution. The goal is to provide the aircraft with excess power capability to arrest hook-point sink rate as rapidly as possible and execute a safe flyaway. Short close-coupled aircraft, with a low H/E distance, are better candidates to allow some rotation during the waveoff.

6.9.2 ADEQUACY

The adequacy of the waveoff criterion to the prediction of V_{pa} is rated as marginal.

The Carrier Suitability Testing Manual, reference 51, allows the following waveoff techniques:

- a) A constant AOA (increasing pitch attitude). This is the desired technique and should be the baseline for early evaluation of a design configuration. Other techniques can be explored if the configuration allows for such variation (limited in-flight engagement potential).
- b) Constant pitch attitude (decreasing AOA).
- c) Simultaneous aircraft rotation with throttle advancement (increasing AOA to greater than AOA_{pa}).

The second technique offers the lowest risk of in-flight engagement but can be considered the most demanding since AOA is reducing with increasing speed. The least demanding technique, but the one that offers the highest potential for in-flight engagement, is the third technique where aft stick and higher AOA's are permitted to help arrest the sink rate. The first technique is a reasonable compromise for early assessments due to the limited aerodynamic data required and the procedure is not computationally intensive. As the aircraft and models mature, it is reasonable to allow discussion with the operators and designers to consider alternate techniques to improve waveoff performance.

A primary consideration for the constant-AOA waveoff calculation, as well as the other techniques, involves engine dynamic response. Engine transients can be difficult to estimate reliably early in the design cycle, and their trends with time are not sufficiently well understood to establish meaningful growth margins during development. Despite these minor, but nontrivial, challenges, we can create sufficiently accurate FOM's for waveoff tasks that can be computed using limited information available early in the design cycle. Fidelity improves as the concept matures, but the physics of the problem remain fundamentally simplistic.

Trim thrust for approach at V_{pa} can strongly affect waveoff performance, but the trend with V_{pa} is counter to the other criteria: as V_{pa} increases, waveoff performance degrades. The primary culprit is that the initial sink rate increases as velocity increases (on a fixed negative flightpath), so more height is lost during the fixed time delay allocated for pilot reaction, and bending the flightpath to horizontal consumes more height. As a result, waveoff performance may be used as a constraint for minimizing V_{pa} providing an upper V_{pa} limit.

Reference 1 definition of the waveoff criterion does not provide a specific threshold. To address this issue, reference 2 provides a flightpath trajectory based on F-18C performance. This selection was based partly on the fleet's desire to maintain current waveoff performance characteristics. The F-18C was chosen based on the perception that the F-18C waveoff performance was a satisfactory measure of the minimum threshold.

As discussed in Section 5.7, the large throttle response criterion appears to be somewhat redundant to the waveoff criterion. Additionally, when assessing both the large throttle response criterion with the waveoff criterion as defined in reference 2, it is found that the acceleration constraint of the large throttle response (5 ft/sec^2 in 2.5 sec) does not correlate well with the flightpath trajectory threshold of the F-18C. This leads to the dilemma of having conflicting results using both criteria. The current large throttle acceleration requirement may not be a direct measure of waveoff capability. However, large throttle acceleration may be used as a surrogate early in design if modified to correlate with waveoff.

6.9.3 SUMMARY

The waveoff criterion should take precedence over the large throttle response criterion. The waveoff performance as implemented in the JSF JMS, reference 2, was based on F-18C performance which requires additional justification if this threshold is to be applied in the future. It is recommended that the threshold should be based on a geometrical time relationship of a minimum waveoff window. Therefore, the waveoff criterion was rated as relevant to the CV approach task but marginal with

respect to its adequacy. It is recommended that future waveoff criteria use a fixed WOD condition for waveoff performance prediction.

6.10 BOLTER

6.10.1 RELEVANCE

The bolter criterion was rated as relevant to the CV approach task.

Bolter is an operationally significant maneuver due to hook skips and long landings. As such, it is therefore necessary to address the minimum capability required to ensure acceptable operational performance. While bolter performance is independent of V_{pa} , it is a factor in the determination of the minimum WOD.

6.10.2 ADEQUACY

The adequacy of the bolter criterion to the CV approach task was rated as marginal.

The JSSG definition contained in reference 1 does not present allowable thresholds relative to aircraft CG sink off the angle deck. This is considered a significant deficiency. Reference 2 specifies no CG sink from the pilot's DEP. Historically, no sink was allowed at the aircraft CG. This is more restrictive than the JSF JMS definition, which allows the designer to consider the perceived pitch rate effect on the pilot. Even earlier definitions have set "desired" performance at nosewheel liftoff or main gear liftoff prior to the end of the angle deck.

At constant WOD, if the aircraft is not constrained by sink speed, hookload, or arresting gear capacity, increasing V_{pa} increases ground (deck) speed. When limited by these factors, the deck speed is controlled by adjusting WOD. The fixed distance available is thus covered in less time, which degrades performance. If deck speed is too high, the resulting performance may be unsatisfactory because there may be insufficient time to rotate the aircraft to flyaway attitude and reduce sink off the angled deck. However, V_{pa} increases as approach AOA decreases. In this case, the total pitch angle change (approach to on-deck back to approach) is lower. As a result, the time required to achieve flying attitude is reduced. The net change in performance may actually be better if approach AOA is reduced even if the approach speed increases. For a given V_{pa} and AOA, more WOD generally makes the task easier. The increase in WOD reduces the ground (deck) speed, providing more time to accomplish the task.

One of the more important elements of bolter performance is the perceived sink by the pilot. It is desired that the pilot senses no sink coming off the angled deck. This is particularly critical at night. Therefore, it would seem the reference 2 definition suits the operational need. It is not particularly important that this level of performance be satisfied at V_{pa} for a mission loading. As pointed out earlier, it is not intuitively obvious that increased V_{pa} will result in improved bolter performance. It is more appropriate to apply the criteria at a specific WOD and aircraft loading.

6.10.3 SUMMARY

Bolter performance is relevant to the CV approach task and is rated as marginal with respect to the adequacy in assessing the CV approach task. The JSF JMS definition, reference 2, is consistent with the operational need. The JSSG definition, reference 1, is inadequate since it does not address aircraft sink. The bolter performance evaluation should be conducted at a fixed WOD at the critical loading.

CHAPTER 7: CARRIER APPROACH CRITERIA DEFINITION ALTERNATIVES

7.1 GENERAL

The current CAC provide the aircraft designer metrics through which the aircraft can be assessed to determine its ability to meet the demanding CV approach and recovery task, based on decades of USN experience. Aircraft designs have significantly changed over the past 40 years, while the criteria have undergone only modest changes, as discussed in Chapters 2-6. A cursory analysis of safety data indicates that there is no longer a correlation between V_{pa} and mishap rate. Therefore, the assessments of Phase I provide strong motivation to investigate ways to address the weaknesses discovered in the CAC. It is recommended that a Phase II effort be conducted to accomplish these objectives.

This chapter proposes avenues of investigation to address the deficiencies of the existing criteria. Initial investigations of a new paradigm for predicting V_{pa} are also presented. Finally, implications for Unmanned Aerial Vehicles (UAV's) are discussed as part of recommendations for further assessment.

7.2 APPLICATION OF TASK-BASED AND ANALYTICAL CRITERIA

In this section, two methods of specifying CV approach criteria are presented: the task-based method and analytical method. Each of these approaches has their advantages and disadvantages. Analytical criteria are advantageous because they can be employed from virtually the first day of program initiation. For example, stall speed may be calculated as soon as the first lift curve is obtained from analytical estimates or the wind tunnel. However, as the design matures, experience has shown that analytical criteria lose significance. For example, stall speed determined from flight tests is much more reliable than analytical predictions. Task-based criteria are advantageous because they directly relate to how the aircraft is operated, and are thus much more likely to be relevant and adequate to predict V_{pa} . The disadvantage of task-based criteria is that they are only as reliable as the lowest fidelity model being used in the prediction. Thus, it is impractical to use task-based criteria until the database is sufficiently mature to provide credible analyses.

In spite of the desirability to apply task-based criteria throughout the entire development process, reality suggests that database and control system scope and fidelity will really not be in a sufficient position for full nonlinear 6-DOF piloted evaluations early in the development cycle. This implies that some application of analytical criteria will be necessary up to the point in the development where there is adequate breadth and confidence in the models to conduct piloted evaluations.

It is important that analytical criteria be directly traceable to the approach task. Conflicting interpretations between the government and contractor over the application of the criteria would be resolved if there is a clear lineage between the operational mission and evaluation criteria. Therefore, it is not enough to develop a standardized set of evaluation tasks but it is also necessary to define desired levels of performance for these tasks back to the analytical criteria that can be applied for evaluation purposes.

At what point does it make sense to transition from analytical criteria to task-based criteria? There is no formal milestone associated with model and control system maturity. It is difficult, a priori, to determine the time when the full nonlinear database has sufficient scope and confidence that it should be used for formal evaluations without first understanding the wind tunnel test plan, planned database updates, and control system development plan. Therefore, it is recommended that a joint government/contractor team develop an assessment or evaluation plan that includes the transition from analytical to task-based criteria evaluation based on the maturity of the simulation. The plan and critical milestones should be presented to government and contractor leadership for concurrence. It is reasonable to expect that this evaluation plan include identification of significant events and database fidelity assessment strategies for review. Formal development of database maturity criteria should be considered.

How would this process work in a future acquisition? Early in development, the contractor will rely on the analytical criteria to conduct configuration assessment and trades. The government will rely on the analytical evaluation to identify potential risks of the proposed or candidate configuration. It is recognized that the primary configuration trades will be conducted early in the design cycle with the application and assessment being conducted primarily with analytical criteria. This highlights the need for traceability of the criteria to the CV approach task. However, if the contractor has other assessment data (i.e., piloted simulation evaluation) that runs counter to the analytical criteria, this information shall be taken under consideration as part of the risk assessment process. Alternate evaluation or risk assessment methods shall be considered on the merits of the method and maturity of the data.

Performance-based criteria like waveoff and bolter should be reflective of how the aircraft will operate in the fleet. Use of these criteria will continue to be used to assess risk until more thorough evaluation techniques can be applied. Even for these task-based criteria, it is important that an analytical equivalent method be developed. For instance, a near equivalent large throttle response criteria could be developed that was consistent with the required waveoff capability and was simplified enough that it can be applied early in the design process for sizing purposes.

If the task-based and analytical criteria conflict, it is important to determine how the criteria will be used to predict V_{pa} . For example, if the analytical large throttle criterion is satisfied, but the task-based waveoff criterion is not, it may be unclear as to which criterion is more reliable. The determination of the more reliable criterion is dependent upon the maturity of the design. Therefore, it is recommended that Phase II examine methods of reconciling analytical and task-based criteria.

It is recommended that Phase II focus on developing both analytical and task-based criteria. It is further recommended that all analytical criteria be reviewed to ensure that they are traceable to representative operational tasks (figure 31).

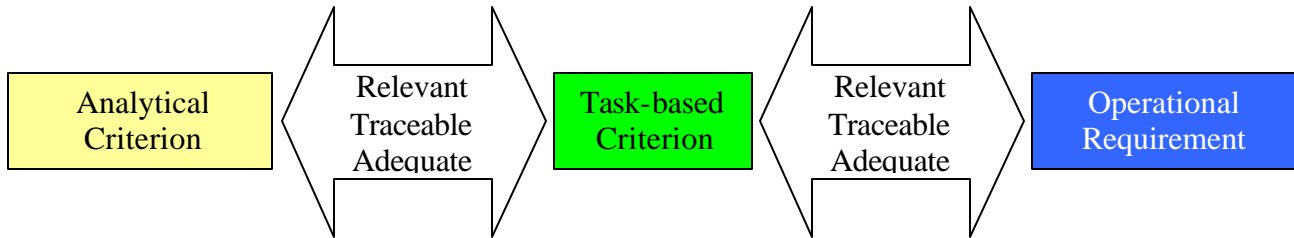

Figure 31: Criterion Traceability

7.3 FURTHER INVESTIGATION OF EXISTING CRITERIA

7.3.1 GENERAL

This investigation revealed that many of the existing criteria are not well-founded. The majority of the criteria are based on empirical data from aircraft designs that are, in some cases, 40 years old. Advances in technology and the inherent life cycle cost impact of these criteria provide the rationale for an experimental program during a Phase II to develop criteria with a stronger operational relevance as well as a clear understanding of the minimum acceptable capability and the sensitivity to other independent factors. This effort should provide criteria that will be justifiable to both the designers in industry and the risk managers in government who ultimately must decide what compromises they can make during the development effort.

The prioritization of the research objectives in Phase II is a complex combination of the soundness of technical fundamentals of the criteria as it relates to existing and future aircraft, the complexity of the proposed experimental effort, the life cycle cost payoff due to relaxation of criteria, and the need for criteria augmentation. For instance, the FOV criterion is likely the most relevant criterion to the operational environment but subtle changes to the criterion could offer significant benefits to the design. In addition, the effects of advanced technology (synthetic vision) could severely impact the applicability of the criterion to future designs. On the other hand, the irrelevance and inadequacy of the popup maneuver point to the need for a new criterion to address GS transfer characteristics.

Phase II criteria development should rely on a combined analytical and task-based approach. Task-based candidate criteria should 1) be consistent with current (and future) operational tasks or maneuvers, 2) contain thresholds consistent with realistic minimums (or maximums) including pilot or LSO opinion, and 3) be based on meaningful design maneuvers. By grounding the candidate criteria to fundamentally sound tasks or maneuvers with performance thresholds clearly established, the minimum level of performance is known and margins are clearly understood. This approach will require early emphasis on accurate model development for valid predictions and full-fledged evaluations. This process translates into more demanding requirements for the simulation tools at an earlier stage in the development process. The task-based paradigm clarifies the allowable design space in which the designer can make configuration trades. Finally, the engineering community and program management will be provided with a set of justifiable, traceable, operationally significant, and defensible criteria.

The following section presents areas for Phase II investigation, using the existing criteria as a starting point.

7.3.2 GLIDE SLOPE TRANSFER (POPUP)

Because the popup maneuver (as defined in reference 1) is rated irrelevant to the CV approach task and the prediction of V_{pa} , it is recommended that research be conducted to implement a relevant and adequate alternative. A research effort is proposed to develop a short-term flightpath response criterion that would consider use of both aerodynamic and propulsion controls to effect GS transfer and control.

The popup maneuver is a criterion that dictates the incremental load factor available while limiting the amount of drag on the aircraft in attempting to generate the additional lift. It translates into an aerodynamic requirement since power is fixed during the maneuver. It is acknowledged that pilots, when flying back-side, use thrust to control flightpath with early application of pitch attitude/AOA to augment the response. Since this criterion is such a significant factor in determining the wing area and the margin from stall and no other flightpath control requirement currently exists, there is considerable impetus to develop a clear criterion that would address the possible tradeoff between thrust response and aerodynamic response. A new criterion could be evaluated in a maneuver that is more representative of the type of GS corrections required at the ship. This may permit the wing design to be optimized to other performance-based criteria (e.g., mission radius) and potentially reduce both acquisition and life cycle cost.

Some considerations for candidate Phase II criteria to address GS transfer include:

- a) What is the minimum aerodynamic flightpath response capability regardless of thrust response or inclination? What is the sensitivity with increasing thrust induced flightpath change?
- b) What is the desired short-term flightpath response character - rate, overshoot, magnitude, etc.?
- c) How much of the available lift margin (to stall) can be used to satisfy the capability?
- d) What is the sensitivity to thrust bandwidth, total available thrust, and thrust inclination?
- e) How does the criterion change for front side operation vice back-side operation?
- f) What if a degraded propulsion system or other flight controls system failure occurred?
- g) What are the consequences of degraded modes that would cause more reliance on basic aerodynamics or on suboptimal control laws?

As part of the Phase I research effort, a preliminary study was conducted in the USNTPS fixed-base generic simulator to investigate parametric sensitivities and determine if more representative maneuvers could be performed for evaluation of GS tracking performance. The results are discussed in the following section.

7.3.2.1 Test Pilot School Simulation

In the existing array of CV approach design criteria, there has not been an explicit requirement for a minimum level of short-term flightpath response. That is, there is no criterion that provides a direct minimum level on how aggressively the pilot should be able to track the GS either from the FLOLS or from an electronic GS indicator. One problem that a short-term flightpath response criterion would address is the ability to make sufficiently rapid corrections to GS error within the limits inherent in the final approach to the carrier as shown in figure 32. Useful FLOLS guidance begins at a range of approximately $\frac{3}{4}$ nm from the carrier. All flightpath corrections must be successfully completed and a steady state achieved no closer than about 1,000 ft from touchdown. This crucial task requirement lacks any explicit requirement of aircraft performance or maneuverability.

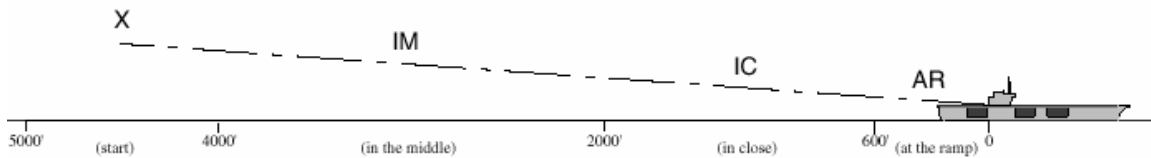

Figure 32: Profile of the CV Approach Task

The USNTPS experiment evaluated variations in thrust inclination angle and heave damping. The baseline configuration used the F-18A. Three test pilots evaluated this matrix in varying degree. Three initial conditions were chosen to assess GS tracking performance. The first condition was a straight-in approach initiated from a low start. The second condition placed the pilot on the rollout of the turn to final. The third condition was identical to the first; however, an abrupt step in altitude was introduced at various ranges from the ship. Within the scope of the experiment, data (pilot CHR) indicate that higher thrust inclination angles and higher heave damping values provided improved short-term flightpath response. In addition, the third initial condition was considered to represent a “last significant glide slope correction” capability. Limitations of this experiment and additional details are contained in Appendix C.

Large thrust inclination configurations received favorable pilot ratings. This result must not automatically be accepted without also applying a reasonable limit on thrust control power. This is considered a form of DLC. Whether furnished with aerodynamic force or propulsive force, DLC has practical limits.

The role of airspeed (and subsequently AOA) regulation parallels that of GS error regulation. Pilot control of airspeed can so greatly influence the overall pilot workload and therefore pilot ratings. The results of the experiment were:

a) General Results:

- 1) Using the technical approach and measurement techniques employed in the USNTPS simulation, several factors relating to the CV approach task can be successfully evaluated.
- 2) Adjustment of some math model features (e.g., the need for AOA stability), tuning of measurement tools (e.g., distance and amplitude of step disturbances to GS error), and streamlining of the test matrix is required.
- 3) It is feasible and advantageous to use a “plug-in” simulator math model based on Matlab/Simulink tools. This permits the portability of the math model to other simulator facilities without major reprogramming and allows offline analysis of the vehicle characteristics.

b) Specific Results:

- 1) Heave damping and effective thrust inclination are two sensitive airframe design parameters.
 - a. Both characteristics influenced pilot ratings and comments over wide ranges.
 - b. In general, pilots preferred higher thrust inclination angles. This may be an indicator of the desire for rapid thrust response on GS.
 - c. Pilots found that larger amounts of heave damping improved task performance at low thrust inclination angles. At thrust inclination angles of 25 deg or greater, there was little to no correlation with the level of heave damping.
- 2) Evaluation pilots produced useful comments regarding pilot technique (use of throttle and pitch-attitude controls).
 - a. Qualitative pilot comments and ratings indicate that pilots desire that the flightpath change rapidly with throttle input and that minimal correction to airspeed be made with the stick.
 - b. Qualitative pilot comments indicate that minimization of “glide slope lag,” i.e., the minimization of “leading the correction” with the throttle is highly desirable.
- 3) Guidance information has a strong effect on the pilot’s ability to perform the carrier approach task. Results indicate that the HUD symbology is significant to the pilot’s assessment of the task. Pilots would often attempt to measure their performance by the degree that the velocity vector (flightpath indicator) moved outside of the E-bracket (airspeed indicator).

- 4) The insertion of a step change in altitude at various ranges from the ship is a useful simulation tool to measure the ability of a configuration to make a rapid GS correction.
- 5) The overall approach task must be considered. The GS tracking task cannot easily be isolated from the AOA (speed) management task. Both tasks are highly coupled for many aircraft configurations. Not unexpectedly, those configurations for which tasks were decoupled (such as high inclination of the effective thrust angle) were rated more highly.

7.3.2.2 Future Efforts

Because of the limited USNTPS simulation fidelity, these results do not have sufficient credibility to serve as a basis for either new criteria or modification of existing ones. Therefore, selected limited-scope experiments must be run in an acceptable facility. An in-flight simulator is preferable but a large-amplitude motion simulator such as the NASA Ames Vertical Motion Simulator may suffice. The ultimate goal of this effort should be to develop an appropriate GS correction task and response criteria for both front-side and back-side operation including thrust inclination axis, pitch attitude coupling, and thrust bandwidth. Required aerodynamic capability for GS tracking in terms of incremental load factor should also be considered

In order to parallel existing FQ criteria, it is recommended that short-term response metrics based on bandwidth should be considered. Where such criteria might apply to the in-close terminal portion of the final approach, a wavelength criterion should be considered.

Any future piloted-simulation effort should include careful measurement and assessment of pilot technique. This requires not only the gathering of time history and pilot opinion data but also an analysis effort dedicated to quantification of pilot performance. Such analysis techniques now exist for discrete tasks such as correction of GS error and AOA tracking.

An experimental program is proposed during Phase II to investigate more operationally representative tasks like step GS corrections and tracking for a variety of longitudinal and thrust responses. A fixed-based piloted simulation should be conducted to further refine the results from the USNTPS simulation to determine acceptable boundaries on critical terms (heave damping, drag bucket, thrust response, etc.). This investigation should also address degraded conditions. Once an evaluation task technique has been established, it should be possible to investigate the tradeoff between these parameters to establish acceptable minimums to meet the required GS correction capability. The findings should be evaluated and verified using a variable stability aircraft to fly simulated FCLP's. Following the basic matrix, several secondary parameters should be analyzed, including the effects of closure speed, speed stability, pitch bandwidth, thrust bandwidth, and separate or blended DLC. At a minimum, the goal of any follow-on effort should be to establish the minimum acceptable and desired character of the flightpath response for CV approach using both stick and throttle inputs.

7.3.3 FIELD OF VIEW

The FOV criterion was found relevant and adequate to determine V_{pa} . During preliminary simulation studies (documented in Appendix D) some pilots suggested that up to 1 deg of over-the-nose FOV could be reduced without significantly impacting the CV recovery task if sufficient benefit for this reduction could be achieved in the overall design of the aircraft. The importance of FOV criterion as a design driver plus the emergence of synthetic vision technologies warrants further investigation. Due to limitations associated with the simulation, higher fidelity simulation and flight-testing could be explored to see if this reduction is indeed achievable. Reduction in the over-the-nose FOV (even as low as 1 deg) would provide the aircraft designer with significantly more design flexibility to meet other aircraft performance requirements by reducing transonic and supersonic drag. Canopy integration is a significant factor relative to transonic acceleration performance.

Further piloted simulation in a high fidelity simulator should be conducted with a variety of aircraft models. Effects due to turbulence and gusts in both day and night visual environments should be investigated. Obstructions may be used to reduce the FOV of most projection systems. Ultimately, if piloted simulation shows the potential for further reductions in the FOV then flight testing would be warranted on shore and at the ship using the FLOLS. LSO feedback on landing performance should be a critical component to the in-flight evaluation. Reduced FOV of less than 1 deg should also be evaluated to identify any trend with degraded FQ or landing performance. A 0.5 deg reduction will result in a FOV that is more consistent with the majority of approaches which are executed at 3.5 deg GS.

The emergence of synthetic vision technologies would warrant development of a new, or at least the modification of the reference 1 criterion. Several technical approaches to synthetic vision have been investigated with some success. However, the tradeoff of reduced outside-the-cockpit FOV and increased artificial cueing is not well understood. Additional testing is required to assess the strengths and weaknesses of synthetically derived visual cues. It is recommended that the reference 1 FOV criterion should not be relaxed in light of advanced technologies like synthetic vision until operational experience with such techniques are developed and satisfactorily demonstrated. It is recommended that the effect of synthetic vision on V_{pa} be considered as a Phase II effort.

7.3.4 FLYING QUALITIES

Beginning with the JSF JMS, reference 2, recent FQ requirements trends have been towards the application of performance-based requirements in lieu of traditional design metrics. One advantage of this approach is that it provides the designer more flexibility from a systems engineering perspective and does not hold the designer to specific design metrics that in the end may not contribute to operational effectiveness. The military rotorcraft industry has used this approach successfully with the adoption of the ADS-33 design specification, reference 120.

If mission-representative tasks can be replicated in piloted simulation at an early stage in the design, it is possible that simulation could be used to evaluate the FQ for CV recoveries. This opens the debate on simulation fidelity, control system maturity, as well as aerodynamic database confidence prior to making meaningful evaluations that would have long-term impact on the development of a

configuration. General feedback from industry obtained in Phase I indicates that the level of fidelity needed to arrive at meaningful and accurate conclusions about a particular aircraft design is beyond their ability to provide it at an early stage like a Milestone A decision point (i.e., source selection). Thus, there are distinct advantages to simple, easy to apply, reliable first-order design metrics that can be used to evaluate the risk of a configuration to determine if it is indeed in the "ballpark". For example, classical roll performance criteria can be applied in a first-order sense to size the lateral control power available at the critical speed of interest with a few assumptions. This investigation has generated substantial debate as to what role piloted simulation should play in evaluating the carrier suitability (recovery) potential of a configuration as part of a source selection exercise.

Meaningful tasks must be developed that adequately exercise the dynamics of the aircraft, are representative of the mission, and can produce credible results. Similar to land-based envelope expansion, a set of standardized evaluations tasks should be developed to assess CV approach FQ. It is recommended that Phase II develop a set of off-nominal initial conditions for CV approach tasks that would require the pilot to aggressively eliminate the offsets to place the aircraft on-condition prior to touchdown. Offsets would include both lateral and GS offsets with speed errors. Once the task has been developed, variations in the aircraft response by adjusting the closed loop performance and handling qualities will be conducted to establish the minimum thresholds in GS, lineup, and speed response bandwidth and overshoots. After definition of the desired response, the results can be translated into aircraft performance metrics that may be required to achieve the desired response. While multiple sets of solutions are possible, establishing the desired response gives the designer the requisite information required to evaluate a given configuration.

7.3.4.1 Roll Control

Although the roll control criterion is considered marginally adequate, research suggests that there may be more optimal ways of specifying roll control in the power approach configuration. It is recommended that piloted simulation and/or flight test research should be conducted to develop a more operationally representative lateral lineup task for evaluating lateral axis handling for CV approach. The open loop time-to-bank criteria, while easy to implement and verify in flight, is not representative of the types of lineup corrections that the pilot will be performing during an operational final approach scenario. Therefore, it is critical that the roll control criterion be representative of the operational need. Others have found that effective time delay is a more important factor in establishing good lineup FQ. In a related but indirect sense, roll coordination is a factor that has played an important role in the lineup FQ but there continues to be debate of the type of sideslip response that is indeed optimal.

7.3.4.2 Flightpath Stability

As previously discussed, it is apparent that the reference 1 flightpath stability criterion is inadequate for back-side operations. There is currently no criterion guiding the required thrust response for back-side operations. While there are likely limitations on how unstable the flightpath response to changes in velocity is to pilot opinion, the worst case may be the neutral stability case. It is possible that the existing thrust response criteria (small throttle response) has indirectly provided a thrust response that is sufficient for the levels of flightpath stability that have been historically encountered. It is recommended that the effects of flightpath stability be evaluated as part of the

Phase II effort to define flightpath control metrics. For aircraft designed to be flown with the back-side technique, it is recommended that the flightpath stability criterion not be used in the prediction of V_{pa} .

7.3.5 STALL SPEED MARGIN

Even with digital flight controls, stall can be accompanied by unsatisfactory characteristics like degraded lateral/directional FQ, excessive drag (low specific excess power capability), unsteady effects (buffet), and in some cases, an undesirable pitchup. In light of this, it is desirable to maintain some margin between V_{pa} (AOA) and the V_s (AOA). Recent history suggests that stall margin is not a significant factor for V_{pa} determination. LEX forebodies have extended the stall AOA much beyond the operational need for most approach and landing operations. In the assessment of stall margin with aircraft equipped with strakes or chines, care must be taken to integrate the vortex dominated lift with wing lift to minimize local buckets in the lift curve. It is possible that the stall speed/AOA will be defined at this lower AOA if the reflex in the lift curve is large enough. In this case, stall margin could be a factor. Prior to advanced digital IFPC, historical experience suggested that a V_{pa} of 1.3 times V_s was a good initial estimator to size the wing in the early stages of the design. As the configuration matures and control laws are developed, this becomes a less significant metric.

The effects of localized nonlinearities of the lift curve and drag polar should be evaluated in a piloted simulation for the impact on approach FQ. Associated unsteady effects and degraded FQ in this region should be intentionally introduced. The relevancy of this criterion must be better understood in light of advances in aerodynamics and flight controls. Particular attention should be paid to Class II and Class III aircraft as these platforms typically have V_{pa} closer to V_s .

7.3.6 FLIGHT CONTROL LIMIT SPEED

No specific Phase II research is planned to further develop or mature margins on FCLS. It is anticipated that if the contractor employs limiters in flaps down control laws, then some accommodation should be required between the contractor and procuring agency to determine the acceptability of the margins used in determining the flight control limiter. It is expected that definition of operational speeds such as V_{pa} will not be located at or near the FCLS.

7.3.7 LONGITUDINAL ACCELERATION (LARGE THROTTLE RESPONSE)

The large throttle response requirement value of 5.0 ft/sec^2 in 2.5 sec for longitudinal acceleration is relevant but the adequacy is marginal. The thrust level and thrust response required by this criterion can be directly related to the ability to waveoff which is a key safety parameter and as such should be correlated with whatever waveoff criterion is adopted. The requirement is intended to provide margin for an aircraft at IOC, which means that as the inevitable weight growth occurs during the life of the aircraft the capability will decline unless an equivalent thrust growth occurs. Investigative efforts for Phase II should concentrate on the possibility of combining the large throttle response and waveoff requirements and establishing the minimum requirement to address the inevitable weight growth during the life of the aircraft. Phase II should also investigate whether the requirement should vary with closure speed. Although not to be used as a "design to" metric, it still is useful for

evaluating candidate engine/airframe configurations and for troubleshooting negative pilot comments regarding waveoff performance.

7.3.8 SMALL THROTTLE RESPONSE

As stated in the previous chapter and discussed in Chapter 2, the small throttle response criterion is relevant to the determination of V_{pa} . It is recommended that Phase II investigate the magnitude of the thrust and throttle changes required for satisfactory GS corrections and the necessary engine response necessary to provide the desired aircraft response. A candidate criterion could be developed based on a throttle bandwidth for small throttle inputs. The plan for development of a short-term flightpath control metric, which would address thrust control of flightpath is described in Appendix C.

7.3.9 WAVEOFF

While the JSSG, reference 1, provides no threshold of acceptable waveoff performance, the JSF JMS, reference 2, provides the F-18C waveoff performance as a function of WOD for evaluating the acceptability of JSF waveoff performance. These threshold levels of performance are not supportable without further justification. The use of load-factor (rotating above approach AOA) will improve performance but not all configurations can safely rotate to higher AOA's due to in-flight engagement risks. Additional justification is required relative to the F-18C levels of performance. It is imperative that the waveoff task be analyzed to discern how much tailhook sink is allowable. LSO feedback is critical to arriving at a suitable conclusion. As a minimum, it is recommended that the waveoff criterion be reworked for a fixed WOD. It is recommended that the waveoff criterion be refined in a Phase II effort to include the LSO perspective. In addition, it is further recommended that a Type-2 waveoff (one ball high, throttle cut to idle for 2 sec, throttle to Mil for waveoff) be considered as an evaluation maneuver in addition to the standard definition waveoff. This is an operationally relevant maneuver that may be particularly challenging to large single-engine configurations. The implementation of this type of waveoff is called out in the JSSG, reference 1, but it is recommended that reference 1 incorporate waveoff minimum thresholds of acceptable performance.

7.3.10 BOLTER

There have been significant variations in the specified bolter performance over the years. While the reference 2 formulation (no sink at the DEP) is likely to be close to the minimum allowable, it is clear that pilot opinion is not favorable of a sinking sensation after leaving the angle deck on a bolter during night CV operations. Calculating the sink at the DEP allows the designer to take credit for perceived R/C due to positive pitch rate. A motion-based simulation would be ideal to identify if the pilot is willing to tolerate any significant sink rate during a bolter. If further relaxation of the bolter criterion were to be considered, piloted simulation assessment should be required to confirm the acceptability of the response.

7.4 OTHER ASSESSMENT AREAS

7.4.1 OPERATOR CONCEPTS

As discussed in Section 4.5.4.2, alternative paradigms exist that may impact the CAC. Backside flying technique is an artifact of the speed and AOA that carrier-based aircraft typically operate during shipboard recovery and should not necessarily be the design path if other options exist. For example, rapid advances in digital fly-by-wire flight control technology have made possible the development of reliable autothrottles so that even though on the back-side of the power curve a front-side flying technique can be retained. Control automation also does not necessarily preclude the need for eliminating manual modes. For example, a manual throttle mode is still required to execute a waveoff. Application of the CAC may require flexibility based on the adoption of advanced control modes for CV approach.

7.4.2 UNMANNED AERIAL VEHICLE IMPLICATIONS

Technology is available to UAV's with fully automated landing systems. Visibility will not be a design constraint and FQ requirements will not be driven by pilot physiological limitations, such as g-onset and attitude rate limitations. Pilot technique will not factor into the design space. As with piloted aircraft, cost effectiveness will still drive V_{pa} to the ship arresting gear limitations. Also, to retain compatibility with carrier operations waveoff, GS control and bolter requirements similar to piloted aircraft will need to be retained. Therefore, it can be expected that these aircraft would also benefit from ongoing CAC efforts. The Phase II research effort should examine the implications of the CAC as they relate to UAV's.

CHAPTER 8: REQUIREMENTS DEFINITION ALTERNATIVE

8.1 GENERAL

Chapter 6 showed that all the CAC, except for the FOV criterion, were found to be deficient relative to either their relevancy or adequacy to assess the CV approach task. As a result, Chapter 7 discussed alternative definitions for CAC criteria so that they can be credibly applied for future carrier-based programs. However, simply addressing the noted deficiencies of the CAC is not enough to ensure a fully balanced solution based on realistic operational requirements and avoid the potential for artificially constraining the designer in the assessment of the CV approach task. Therefore, a review of the requirements selection process to address the Warfighter's operational requirements for the approach task is required. As such, this Chapter presents an alternative view on how requirements could be defined in future programs.

8.2 REQUIREMENTS

8.2.1 SPEED DEFINITIONS

The relationship between V_{pa} , WOD, and engaging speed is significant to the discussion of approach requirements. Figure 33 illustrates the relationship of these three quantities. Touchdown speed is defined as 105% of V_{pa} . The 5% factor added to the touchdown speed is not arbitrary. It is based on actual ship survey data and the statistical variation seen in the actual touchdown speeds. The percentage varies with each aircraft. However, for design purposes, a 5% factor is used as a nominal value to define the touchdown speed. Engaging speed is defined as touchdown speed minus WOD. Closure speed is the relative speed between the aircraft and the ship. The engaging speed limit is the minimum of the arresting gear limit speed, hookload limit speed, or limiting sink speed. The engaging speed must not exceed the engaging speed limit speed for safe recovery. WOD is generated by the combination of natural wind and/or ship speed.

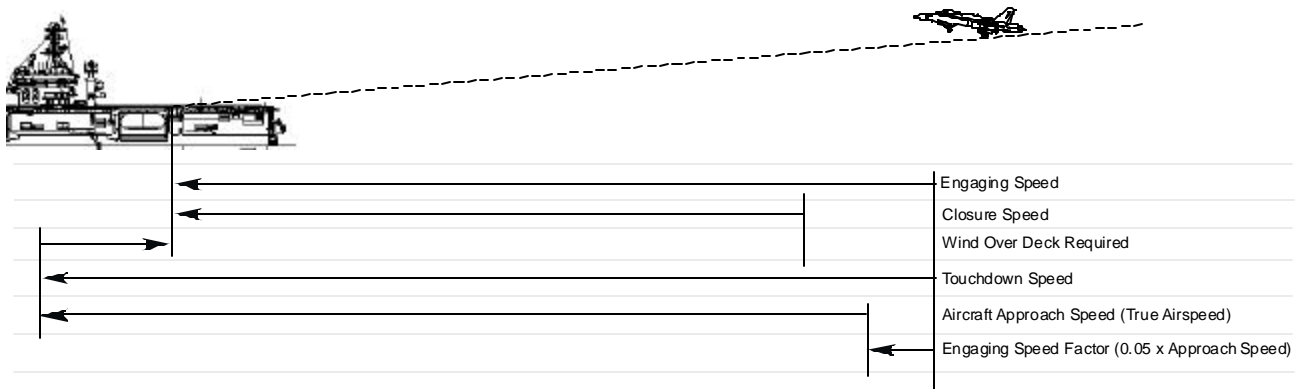

Figure 33: Speed Relationships

8.2.2 APPROACH SPEED

Common USN practice has been to use V_{pa} as a KPP for carrier-based aircraft acquisition programs. In addition to specifying the V_{pa} in knots true airspeed at a specific design loading, requirements have also defined the arresting gear limit speeds and maximum allowable WOD. The practice of

separately defining a limit Vpa, arresting gear limit speed, and the WOD limit in fact overspecifies the problem, which often times results in incompatible requirements. In fact, only two of the three variables are required to define a maximum Vpa.

In the past, Vpa has been defined at a fixed value (e.g., 145 kt) and has been tracked as a KPP. Discussions with RO's have indicated that the primary reason for explicitly specifying Vpa is the perception that high Vpa (>145 kt) results in increased mishap rate. A review of the Vpa safety implications was addressed in Section 4.7. That review provides definitive data that dispels the concern that safety is compromised with increasing Vpa. Although data from 1964 indicated a strong relationship between Vpa and mishap rate, the advancements in technology, training, and operating procedures since that time appear to have contributed to the dramatic reduction in CV landing mishap occurrences. However, as stated in Section 4.7, it should not be construed that a correlation between Vpa and mishap rate does not exist for Vpa values greater than those surveyed (i.e., 153 kt).

Therefore, having dispelled any existing correlation between Vpa and mishap rate, an alternate requirements process can be explored that does not require an explicit value for maximum Vpa at a specified loading. This alternative process would entail defining the engaging limit speed (based on arresting gear capacity, hookload, or landing gear capability) and a required WOD. This process offers advantages to both the designer and the government.

8.2.2.1 Value and Design Benefits

The following example illustrates a potential advantage of the proposed process. Consider the design constraints imposed under the following requirement definitions which overspecifies the requirement.

$$\begin{aligned}V_{AG\ LIMIT} &= 145 \text{ knots} \\WOD &= 10 \text{ knots} \\V_{PA} &= 140 \text{ knots}\end{aligned}$$

Using the arresting gear limit speed and WOD, a maximum possible Vpa can be computed directly.

$$\begin{aligned}WOD &= V_{TOUCHDOWN} - V_{AG\ LIMIT} \\V_{AG\ LIMIT} &= V_{TOUCHDOWN} - WOD \\V_{TOUCHDOWN} &= 1.05 \cdot V_{PA} \\V_{AG\ LIMIT} &= 1.05 \cdot V_{PA} - WOD\end{aligned}$$

From these relationships, a maximum Vpa is determined.

$$V_{PA} = \frac{(V_{AGLIMIT} + WOD)}{1.05}$$

$$V_{PA} = \frac{(145 + 10)}{1.05} = 147.6 \text{ knots}$$

The maximum Vpa based on the arresting gear limit speed at 10 kt WOD is computed to be 147.6 kt. However, in addition to defining a WOD and arresting gear limit speed, this example also explicitly defines a maximum Vpa requirement of 140 kt resulting in two Vpa limiting speeds.

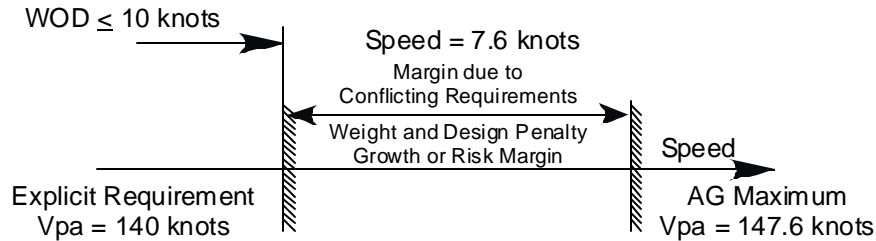

Figure 34: Disadvantage of an Explicit Vpa Requirement

As illustrated in figure 34, the impact of these conflicting requirements results in a 7.6 kt difference. Due to the explicit Vpa requirement, the design space is further constrained over and above the arresting gear limit speed. Forced to design to the lower Vpa requirement (i.e., 140 kt), the resulting configuration will be forced to operate at a higher AOA, adopt a larger wing, or integrate a more complex high-lift system. This will likely result in increased weight, cost, and/or complexity to the program and design.

In contrast, if designed to only the capability of the arresting gear, there is an immediate 7.6 kt relief on Vpa allowing for a Vpa of 147.6 kt. This is illustrated in figure 35.

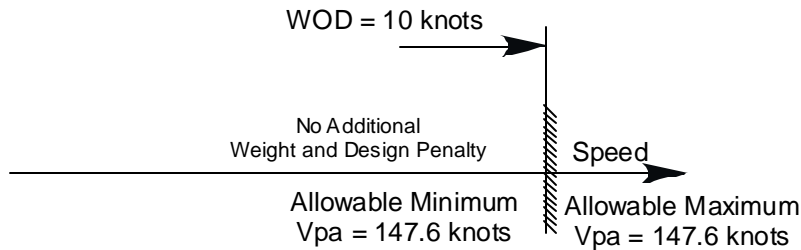

Figure 35: Alternative Approach Design Benefit

Unlike the first example, the designer can take full advantage of the available design space to apply the CAC for the prediction of the minimum Vpa without incurring additional weight and other design penalties.

8.2.2.2 Requirements and Risk Benefits

The alternative process also has advantages with regard to the justification of the maximum Vpa to the PMA. Matching the required Vpa to realistic operational constraints instead of an arbitrary Vpa threshold strengthens the justification for the Vpa requirement.

In the previous example presented above, the removal of the 7.6 kt margin at first glance appears to increase risk to the PMA. However, the 7.6 kt could be viewed as a margin to accommodate weight growth, aerodynamic uncertainties, or other development risks. In this way, the PMA has a capability to manage risk by way of the WOD requirement. Selection of the maximum specified WOD can be adjusted (lower value) to reflect the perceived risk to the program and anticipated growth during the aircraft's life cycle. The RO can address operational factors and growth through the selection of WOD in the ORD. The PMA can further restrict the WOD to manage risk through the specification. As illustrated in figure 36, a selection of 2 kt WOD results in specifying a 140 kt maximum Vpa.

$$V_{AG\ LIMIT} = 1.05 \cdot V_{PA} - WOD$$

$$WOD = 1.05 \cdot V_{PA} - V_{AG\ LIMIT}$$

$$WOD = 1.05 \cdot 140 - 145$$

$$WOD = 2 \text{ knots}$$

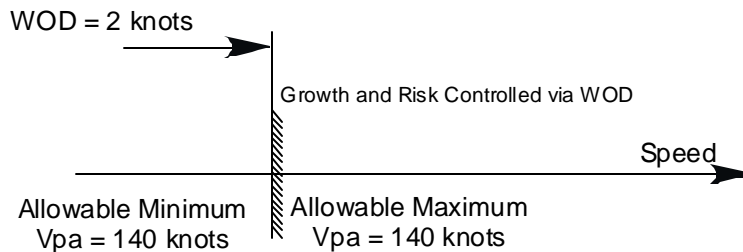

Figure 36: Controlling Risk and Growth through WOD Selection

8.2.2.3 Impact on Carrier Approach Criteria

In the previous discussion, the assumption remains that Vpa is determined by the Vpa criteria. In this process, as outlined in Chapter 5, the minimum Vpa is calculated under each criterion and the maximum defines Vpa. Waveoff and bolter have not historically been used as Vpa criteria. If bolter or waveoff were found to be deficient at Vpa, a remedy might be either a design change or for the contractor to ask for a change in the computation ground rules to allow additional WOD. Using the alternative process, waveoff and bolter are directly integrated into the Vpa prediction for the specified WOD. The maximum Vpa could now be set by either the bolter or waveoff criteria, or the engaging speed limits. The minimum Vpa is still determined by the Vpa criteria.

8.3 SUMMARY

A significant variation in the requirement definition process and the application of CAC criteria and WOD is proposed. It is recommended that further analysis of KPP selection should be conducted in

a Phase II study. Further discussion between the PMA, requirements community, and engineering should address KPP selection if it is desired that a KPP is warranted for the CV approach task.

THIS PAGE INTENTIONALLY LEFT BLANK

CHAPTER 9: CONCLUSIONS AND RECOMMENDATIONS

9.1 GENERAL

9.1.1 CONCLUSIONS

The results of the approach task decomposition provided added confidence that a critical review of the CAC criteria alone was sufficient to highlight any criteria deficiencies and ensure all tasks and elements of the carrier environment were properly considered (Section 1.5.5).

Transition to jet aircraft and employment of the angled-deck carrier necessitated the prediction of Vpa. The primary driver, at that time, for reliable Vpa prediction was to constrain the structural landing loads for design (Section 2.4).

Interviews with former BUAER/NAVAIRSYSCOM aeromechanics leaders, reference 20, indicated that the approach criteria were intended to be used as design aids so that early assessment of aircraft loads could be established. The fact that the CAC evolved as the standard by which demonstration of Vpa is validated is at odds with the original intent of the criteria in that Vpa was to be determined in flight test independent of the design criteria (Section 2.5.4.1).

The current application of the CAC (to define Vpa) is not consistent with the intent of early investigators of CAC development (Section 2.7).

CAC results are used not only as a design tool but also as a standard by which Vpa can be assessed throughout a program. Without the CAC, the challenge to adequately and consistently assess an aircraft design becomes significantly more difficult, resulting in reduced government capability to identify and assess risk (Section 3.2.1.2).

Because Naval aircraft programs almost always involve competition between two or more design concepts, it becomes extremely difficult from an industry perspective to fail to satisfy any of the CAC to meet the Vpa requirement. Therefore, the criteria, although not specifically defined as requirements, in practice become “hard requirements” to the design team (Section 3.2.2.2).

The government uses the CAC to predict and assess Vpa. The ability to make predictions early in the program allows for risk identification and assessment. Industry relies on the CAC to conduct cost and design trades that define the design space from which a design can meet the stated requirements (Section 3.3).

The criticism is balanced by the realization that, while some aircraft may not satisfy all of the current CAC, Naval aircraft over the past 40 years have been designed against an evolving version of the CAC and have resulted in a fleet of carrier suitable aircraft (Section 3.3).

Industry and government agree there must be a set of CAC to aid the government as well as the designer. It was concluded that if all of the requirements and accompanying criteria have a sound technical basis, there would be less debate over the criteria definition and more constructive interchange over design solutions (Section 3.3).

The multiple constraints of CV landing are satisfied by the pilot's control of just three variables - GS, lineup, and AOA. Addition of error rate information improves closed-loop performance. The best closed-loop performance is achieved feeding back error rates rather than displacement errors themselves (Section 4.5.1).

Based on NSC data from January 1980 through May 2001, it is concluded that there is no longer a correlation between mishap rate and V_{pa} within the scope of aircraft reviewed and, therefore, should not be used as an indicator of safety (Section 4.7.2).

This investigation has revealed that many of the existing criteria are not well-founded. The majority of the criteria are based on empirical data from aircraft designs that are, in some cases, 40 years old (Section 7.3.1).

Application of the CAC may require flexibility based on the adoption of advanced control modes for CV approach (Section 7.4.1).

The practice of separately defining a limit V_{pa} , arresting gear limit speed, and the WOD limit in fact overspecifies the problem, which often times results in incompatible requirements (Section 8.2.2).

9.1.2 RECOMMENDATIONS

NAVAIR should define a process for periodic review and assessment of the CAC that includes both government and industry representatives (Section 3.3).

Because of the beneficial impact of HUD cueing on pilot workload during the approach task, HUD considerations should be a primary consideration in designing for the approach task (Section 4.5.1).

Phase II should examine methods of reconciling analytical and task-based criteria (Section 7.2).

Phase II should focus on developing both analytical and task-based criteria (Section 7.2).

All analytical criteria should be reviewed to ensure that they are traceable to representative operational tasks (Section 7.2).

Task-based candidate criteria should 1) be consistent with current (and future) operational tasks or maneuvers, 2) contain thresholds consistent with realistic minimums (or maximums) based on pilot or LSO opinion, and 3) be based on meaningful design maneuvers (Section 7.3.1).

A Phase II research effort should include the implications of the CAC as they relate to UAV's (Section 7.4.2).

Further analysis of KPP selection should be conducted in a Phase II study. Further discussion between the PMA, requirements community, and engineering should address KPP selection if it is desired that a KPP is warranted for the CV approach task (Section 8.3).

9.2 SPECIFIC

9.2.1 GLIDE SLOPE TRANSFER (POPOP) MANEUVER

9.2.1.1 Conclusions

The GS transfer (popup) criterion was rated as irrelevant to the CV approach task as defined in reference 1. Although it is clear that some minimum aerodynamic capability is required, the GS transfer criterion is not a meaningful methodology to provide such capability. A new criterion is required that addresses not only aerodynamic load factor capability for GS tracking but also considers the natural tradeoff with thrust-to-flightpath response (Section 6.2.1).

The GS transfer criterion was rated as inadequate as a metric to ensure adequate GS tracking characteristics and prediction of V_{pa} (Section 6.2.2).

The GS transfer (popup) criterion is inadequate to predict V_{pa} and is unable to predict GS tracking ability (Section 6.2.2).

9.2.1.2 Recommendations

The popup maneuver should not be used in the prediction of V_{pa} (Section 6.2.4).

Development of a short-term flightpath response criterion that addresses both aerodynamic and propulsion system performance is recommended to address the GS tracking task for both full up and degraded modes (Section 6.2.4).

In order to parallel existing FQ criteria, short-term response metrics based on bandwidth should be considered. Where such criteria might apply to the in-close terminal portion of the final approach, then a wavelength criterion should be considered (Section 7.3.2.2).

9.2.2 FIELD OF VIEW

9.2.2.1 Conclusions

The FOV criterion is relevant to the CV approach task (Section 6.3.1).

The FOV criterion is adequate to predict V_{pa} . Fleet experience supports the thresholds in the criterion (Section 6.3.2).

No significant revisions of the FOV criterion are required. Limited reductions of less than 1 deg of the criterion threshold may be explored (Section 6.3.4).

9.2.2.2 Recommendations

The FOV criterion should not be relaxed in light of advanced technologies like synthetic vision until operational experience with such techniques are developed and satisfactorily demonstrated (Section 7.3.3).

9.2.3 FLYING QUALITIES

9.2.3.1 General

9.2.3.1.1 Conclusions

The Level 1 FQ criterion is relevant to the approach task (Section 6.4.1.1).

The adequacy of the Level 1 FQ criterion is rated as marginal (Section 6.4.1.2).

A combined comprehensive analytical and limited piloted evaluation effort is the most efficient process for identifying FQ risks (Section 6.4.1.2).

V_{pa} should not be determined solely on the reference 1 FQ criteria unless more detailed information is not available (Section 6.4.1.2).

The reference 1 FQ criterion has value as a preliminary design metric, but may not be adequate to determine V_{pa} as written (Section 6.4.4).

9.2.3.1.2 Recommendations

A set of standardized evaluations tasks should be developed to assess CV approach FQ (Section 7.3.4).

Phase II should develop a set of off-nominal initial conditions for CV approach tasks that would require the pilot to aggressively eliminate the offsets to place the aircraft on-condition prior to touchdown (Section 7.3.4).

9.2.3.2 Roll Control

9.2.3.2.1 Conclusions

A roll response criterion is relevant as it directly relates to the lineup element of the CV approach task (Section 6.4.2.1).

The roll control criterion is rated as marginal to predict V_{pa} (Section 6.4.2.2).

9.2.3.2.2 Recommendations

The roll control criterion should not be applied in a manner that would limit V_{pa} if sufficient piloted simulation data supports the lower level of roll performance (Section 6.4.2.2).

Additional experimentation is recommended to investigate effective roll time delay (measured from the nonlinear time history response) or roll bandwidth as potential FOM's (Section 6.4.2.2).

Piloted simulation and/or flight test research should be conducted to develop a more operationally representative lateral lineup task for evaluating lateral axis handling for CV approach (Section 7.3.4.1).

9.2.3.3 Flightpath Stability

9.2.3.3.1 Conclusions

The relevance of the reference 1 flightpath stability criterion is rated as marginal to the CV approach task (Section 6.4.3.1).

The flightpath stability criterion is inadequate to predict V_{pa} (Section 6.4.3.2).

9.2.3.3.2 Recommendations

Evaluate the effects of flightpath stability as part of the Phase II effort to define flightpath control metrics (Section 7.3.4.2).

For aircraft designed to be flown with the back-side technique, do not use the flightpath stability criterion in the prediction of V_{pa} (Section 7.3.4.2).

9.2.4 STALL SPEED MARGIN

9.2.4.1 Conclusions

The stall margin criterion was rated as marginal in its relevance to the CV approach task (Section 6.5.1).

The stall margin criterion was rated as inadequate for the prediction of V_{pa} (Section 6.5.2).

The basic concept of maintaining a minimum margin relative to stall is considered sound and should be continued even if it is meaningful only for Class II or Class III aircraft (Section 6.5.2).

A simpler, easier definition of power-on stall is necessary (Section 6.5.3).

9.2.4.2 Recommendations

Evaluate the effects of localized nonlinearities of the lift curve and drag polar in a piloted simulation for the impact on approach FQ (Section 7.3.5).

9.2.5 FLIGHT CONTROL LIMIT SPEED

9.2.5.1 Conclusions

The FCLS criterion is rated as having marginal relevance to the CV approach task for configurations that require an active control limiter (e.g., an AOA limiter) (Section 6.6.1).

The adequacy of the FCLS criterion is rated as marginal relative to the prediction of Vpa (Section 6.6.2).

9.2.5.2 Recommendations

The definition of the rationale and criterion used to define the mechanization of the limiter be coordinated with the procuring activity to ensure sufficient margins exist (Section 6.6.3).

9.2.6 LARGE THROTTLE RESPONSE (LONGITUDINAL ACCELERATION)

9.2.6.1 Conclusions

The large throttle response criterion is relevant to the CV approach task (Section 6.7.1).

The adequacy of the large throttle criterion is marginal in the prediction of Vpa (Section 6.7.2).

While it is clear that the large throttle response criterion applies more to an escape type maneuver than a GS tracking task, a criterion of this form should be maintained as an initial design metric for excess thrust and thrust transient performance for initial engine sizing (Section 6.7.2).

The large throttle response criterion needs to be consistent with any updates applied to the waveoff criterion (Section 6.7.2).

Waveoff performance is the preferred FOM in addressing the desired escape maneuver performance (Section 6.7.3).

9.2.6.2 Recommendations

Phase II should concentrate on the possibility of combining the large throttle response and waveoff requirements and establishing the minimum requirement to address the inevitable weight growth during the life of the aircraft. Phase II should also investigate whether the requirement should vary with closure speed (Section 7.3.7).

9.2.7 SMALL THROTTLE RESPONSE

9.2.7.1 Conclusions

The small throttle response criterion is relevant to the CV approach task (Section 6.8.1).

The adequacy of the small throttle criterion to define desirable GS tracking characteristics and to determine V_{pa} is rated as inadequate (Section 6.8.2).

9.2.7.2 Recommendations

A Phase II investigation of the magnitude of the thrust and throttle changes required for satisfactory GS corrections and the necessary engine response necessary to provide the desired aircraft response should be conducted (Section 7.3.8).

9.2.8 WAVEOFF

9.2.8.1 Conclusions

The waveoff criterion was rated as relevant to the CV approach task (Section 6.9.1).

The adequacy of the waveoff criterion to the prediction of V_{pa} is rated as marginal (Section 6.9.2).

The waveoff performance as implemented in the JSF JMS was based on F-18C performance which requires additional justification if this threshold is to be applied in the future (Section 6.9.3).

9.2.8.2 Recommendations

The threshold should be based on a geometrical time relationship of a minimum waveoff window (Section 6.9.3).

Future waveoff criteria should use a fixed WOD condition for waveoff performance prediction (Section 6.9.3).

The waveoff criterion should be refined in a Phase II to include the LSO perspective (Section 7.3.9).

The waveoff criterion be reworked for a fixed WOD (Section 7.3.9).

Type-2 waveoffs (one ball high, throttle cut to idle for 2 sec, throttle to Mil for waveoff) should be considered as an additional evaluation maneuver in addition to the standard waveoff definition (Section 7.3.9).

Reference 1 should incorporate waveoff minimum thresholds of acceptable performance (Section 7.3.9).

9.2.9 BOLTER MANEUVER

9.2.9.1 Conclusions

The bolter criterion was rated as relevant to the CV approach task (Section 6.10.1).

The adequacy of the bolter criterion to the CV approach task was rated as marginal (Section 6.10.2).

9.2.9.2 Recommendations

Evaluation of bolter performance should be conducted at a fixed WOD at the critical loading (Section 6.10.3).

REFERENCES

1. Department of Defense Joint Service Specification Guide, Air Vehicle, JSSG-2001, of 15 Mar 2000.
2. Joint Strike Fighter (JSF) Model Specification, Joint Strike Fighter Program Office, Distribution Statement D, of 8 Nov 2000.
3. Naval Aircraft Mishap Data, Naval Safety Center, compiled May 1964.
4. Naval Aircraft Mishap Data, during January 1980 through May 2001, Naval Safety Center, compiled May 2001.
5. Swanborough, G., Bowers, P. M., "United States Navy Aircraft since 1911", Putnam Aeronautical Books, London, 3rd edition published 1990.
6. Gossnick, R. A., Armstrong, W. J. "United Stated Naval Aviation, 1910 - 1995", Naval Historical Center, published June 1997.
7. AGARD paper titled "U.S. Navy Pilot Controlled Landing Procedure and Associated Equipment", Nelson, J.H. and Griffin, G.M., presented from 14-18 Jan 1963.
8. McDonnell Aircraft Corporation Report No. 3232, The Minimum Landing Approach Speed of High Performance Aircraft, of Oct 1953.
9. Personal Interview between Mr. J. T. Lawrence and Mr. E. R. Shields of June 2001.
10. NACA RM-A57L11, "A Comparison of Flight-measured Carrier-approach Speeds with Values Predicted by Several Different Criteria for 41 Fighter-type Airplane Configurations" White, Maurice D, Schlaff, Bernard A, and Drinkwater, Fred J, III, of 8 May 1958.
11. NASA Memo 10-6-58A, "A Flight Evaluation of the Factors, which Influence the Selection of Landing Approach Speeds," F.J. Drinkwater and G.E. Cooper, of 1958.
12. Military Specification MIL-A-8629, Airplane Strength and Rigidity, of 12 Mar 1960.
13. Military Specification MIL-A-8860, Airplane Strength and Rigidity, General Specification for, of 20 May 1987.
14. Military Specification MIL-A-8863C(AS), Airplane Strength and Rigidity, Ground Loads for Carrier-Based Aircraft, of 19 July 1993.
15. Aerodynamics and Hydrodynamics Branch of the Bureau of Aeronautics Technical Memorandum No. 1-59, "A Discussion of the Carrier Landing Approach Speed Problem", Linden, J. E., of 15 Jan 1959.

16. BuAer Letter Aer-AD-32 Serial 01184 of 6 Feb 1959.
17. NAVAIRTESTCEN Report No. AD-3089, Effects of Pilot Technique on Minimum Approach Speed, of 17 Feb 1961.
18. Naval Weapons Bulletin No. 3-61, Determination of Optimum Approach Speeds for Carrier Landings, 1961.
19. BUWEPS Problem Assignment RAD33-210, of 17 Apr 1963.
20. Personal Interview between Linden, J., Koven, W., and Andrews, H., NAVAIRSYSCOM Washington Liaison Office, Crystal City, VA, of 30 Apr 2001.
21. NAVAIRTESTCEN Report No. FT-27R-66, Investigation of Feasibility of Performance Demonstration of Landing Approach Speed, Including A-3B Phase, of 16 Mar 1966.
22. G. A. Patterson, Jr., AIAA Paper No. 67-578, "Criteria for Determination of Minimum Usable Approach Speed", presented during AIAA Guidance, Control, and Flight Dynamics Conference in Huntsville, AL, from 14-16 Aug 1967.
23. SD-555-5, Detail Specification for the A-7E Aircraft, of 21 Mar 1968.
24. Grumman Report XA128-105-18, "A-6A Aircraft Substantiation Data Report", of May 1965.
25. "Final Approach: Landing Technique for High Performance Aircraft," U.S. Naval Aviation Safety Center, 1959.
26. NAVAIR 00-080T-80, Aerodynamics for Naval Aviators, Hurt, Jr. H. H., The Office of the Chief of Naval Operations, Aviation Training Division, 1960 (revised Jan 1965).
27. Eldridge, LCDR R. A., "The Carrier Landing Story", Approach Magazine, of Jul 1961, pp. 4-16.
28. Foster, LCDR J. R., "Ramp Strike!", Approach Magazine, of Feb 1963, pp. 1-6.
29. Netherland, CDR R. M. "The Total Approach: Fundamental Instruction in Error Correction," Approach Magazine, of Mar 1965.
30. F-14A Detail Specification SD-561-1 of 10 Jan 1969.
31. CV NATOPS Manual, NAVAIR 00-80T-105, of 21 Oct 1999.
32. RA-5 NATOPS Manual, of 1977.
33. Gilruth, R.R. "Requirements for Satisfactory Flying Qualities of Airplanes," Langley Memorial Aeronautical Laboratory, Langley Field, VA, of Apr 1941.

34. Military Specification MIL-F-8785-4, released in 1959.
35. Military Specification MIL-F-8785B(ASG), Flying Qualities of Piloted Airplanes, of 7 Aug 1969.
36. Military Specification MIL-F-8785C, Flying Qualities of Piloted Airplanes, of Nov 1980.
37. Military Standard MIL-STD-1797A, Military Standard Flying Qualities of Piloted Aircraft, of 30 Jan 1990.
38. Princeton University Report No. 727, Lateral-Directional Flying Qualities for Power Approach, Seckel E., Miller G., and Nixon W., of Sep 1966.
39. NAWCAD Flight Test and Engineering Group Memorandum, LSO Survey, of 17 Dec 1992.
40. T-45A INSURV Yellow Sheet Report No. SA-33, Excessive Pilot Compensation Required to Capture Glide Slope during Simulated Off-Nominal Approaches, of 8 Aug 1989.
41. T-45A INSURV Yellow Sheet Report No. SA-74, Excessive Altitude Loss during Waveoff, of 18 Aug 1989.
42. NAVAIRTESTCEN Memo FT2211, IRT F-111B, "Comments on the Carrier Suitability of Various Airplanes", of May 1966.
43. "BUWEPS Approach Speed Criteria", of Feb 1966.
44. "Determination of Optimum Approach Speeds for Carrier Landings" appeared in Naval Weapons Bulletin No. 3-61, p. 18.
45. Personal Interview with Mr. Ralph A'Harrah (Head of NAVAIRSYSCOM Flying Qualities, c. 1970-1980).
46. TS-169A, Type Specification for Model VFAX Aircraft Weapon System, of 30 Oct 1974, Rev A of 6 Nov 1974.
47. SD-565-1, Detail Specification for Model F-18A Aircraft Weapon System, of 19 Apr 1976.
48. A-6F Detail Specification, Draft, of Dec 1985.
49. Carrier Suitability Testing Manual, 1963.
50. JSF Joint Initial Requirements Document of 1996.
51. SA-FTM-01, Carrier Suitability Testing Manual, with Revision 2 of 30 Sep 1994.

52. DoD Instruction 5000.2, Operations of the Defense Acquisition System, of 4 Jan 2001.
53. Glossary of Defense Acquisition Acronyms and Terms, Defense Acquisition University Press, 10th Edition, Fort Belvoir, of Jan 2001.
54. Aircraft Carrier Reference Manual, NAEC-MISC-06900, with Rev. D, of 1 Nov 1997.
55. Visual Landing Aids General Service Bulletin No. 8, Rev. L, of 2 Apr 1997 with Amendment 1 of 28 Apr 1998, Amendment 2 of 21 Feb 2000, and Amendment 3 of 7 Nov 2000.
56. Aircraft Recovery Bulletin No. 29-12AA for Mark 7 Mod 3 Arresting Gear with Operating Sheave Dampers, NAWCADLKE-4.8.10.4B, of 31 Mar 2000.
57. Aircraft Recovery Bulletin No. 29-13AA for Mark 7 Mod 3 Arresting Gear with Operating Sheave Dampers, NAWCADLKE-4.8.10.4B, of 31 Mar 2000.
58. Aircraft Recovery Bulletin No. 33-12A for Mark 7 Mod 3 Arresting Gear 115 to 125-foot Span with Service Change 428 and Operating Sheave Dampers, NAWCADLKE-4.8.10.4B, of 18 Dec 2000.
59. Aircraft Recovery Bulletin No. 33-13A for Mark 7 Mod 3 Arresting Gear 115 to 125-foot Span with Service Change 428 and Operating Sheave Dampers, NAWCADLKE-4.8.10.4B, of 18 Dec 2000.
60. Aircraft Recovery Bulletin No. 10-10D for All Arresting Gear and Optical Landing Systems, NAWCADLKE-4.8.10.4B, of 18 Nov 1997.
61. Aircraft Recovery Bulletin No. 62-12D, Mark 6 Mod 3 Fresnel Lens Optical Landing System (FLOLS), NAWCADLKE-4.8.10.4B, of 11 Dec 1995.
62. NATOPS Landing Signal Officer Manual, NAVAIR 00-80T-104, with Change 2 of 1 Nov 1997.
63. Theory of Operation, Improved Fresnel Lens Optical Landing System (IFLOLS), NAVAIR 51-40ABA-21, of 1 Oct 1997.
64. Military Standard MIL-STD-2066, Catapulting and Arresting Gear Forcing Functions for Aircraft Structural Design, of 20 Mar 1981
65. Paradise, LT Matthew, Informal Survey of Landing Signal Officers, NAVAIRSYSCOM, Patuxent River, MD, of Dec 2001.
66. Systems Technology, Inc., Technical Report No. 137-2, Carrier Landing Analyses (Final Report), of Feb 1967.

67. Computer Program, NAVAIRSYSCOM 2-DOF Performance Simulation of Popup Maneuver, AIR4322, Unpublished.
68. Personal Interview, Carroll Senn with Nick Vignevic, NAWCAD Lakehurst, Code 4.8.10, Nov 2001.
69. Military Standard MIL-STD-1333A, of 30 Jun 1976.
70. GAEC A2F-1 General Arrangement Drawing 128-10001, Rev H, of 22 Jun 1960.
71. GAC Basic Data Report XA128-105-28, of Nov 1979.
72. GAC E-2C Drawing 123-50001 in Basic Data Report XA123U-101-5, Rev 2, of 29 Feb 1992.
73. GAC E-2C Drawing 123-50001 in Basic Data Report XA 123U-101-5, of 30 Mar 1973.
74. Lockheed S-3A Drawing 1200000, of 19 Jun 1970.
75. DAC T-45A Drawing DA00SA002, Revised 2 Jul 1991, MDA Basic Data Report 94BO115, Rev. A, of 30 Apr 1996.
76. DAC T-45A Drawing DA00SA002, of 25 Feb 1985.
77. GAEC EA-6B Drawing 1128-40001, of 29 May 1967.
78. GAC EA-6B Drawing 1128-42001 in GAC Basic Data Report XA1128-105-12, of Nov 1983.
79. Vought F-8 Drawing CV21-200020, Vought F-8H/J Performance Data Report 2-53310/8R-7201, of 9 Aug 1968.
80. GAC C-2A Drawing 123-60001 of 14 Apr 1982 in Performance Data Report ENG-C-2A/R-83-02, of 5 Dec 1983.
81. GAC Performance Data Report A55-335-R-84-02, of Jul 1985.
82. GAEC W2F-1 Drawing 123-10001, of 1 Jul 1958.
83. GAC Basic Data Report A51-335-R-74-02, of Jun 1974.
84. MDC Basic Data Report MDC A8575, of 1 Nov 1990.
85. MDC F-18E Drawing 74J008703, of 14 Oct 1994.
86. Boeing F-18E/F Basic Data Report Boeing STL 99A0035, of 30 Jun 1999.

87. Vought A-7E Drawing 218-10000, of 29 Jan 1976.
88. DAC TA-4J Drawing 5942900, of 5 Dec 1975
89. Vought F-8 Drawing CV21-200020, Vought F-8H/J Performance Data Report 2-53310/8R-7201, of 9 Aug 1968.
90. North American T-2B Drawing 288-000001 of 23 Jul 1964.
91. McDonnell Aircraft Corporation F-4 Drawing 32-000001 of 27 Mar 1963, F-4S Performance Data Report MDC A6041, of 1 Jul 1979.
92. McDonnell Aircraft Corporation F-4 Drawing 32-000001 of 27 Mar 1963, F-4B Performance Data Report H314, Vol. I, of 16 Jun 1970.
93. North American A3J-3 Drawing 279-000001 of 9 Mar 1962.
94. Malthan, L.V., Hoak, D.E., and Carlson, J.W., "The USAF Stability and Control Handbook (Dat Com), Air Force Flight Dynamics Laboratory, Wright-Patterson Air Force Base, Ohio, 1960, revised Apr 1978 by Hoak, D.E., et al.
95. F/A-18E/F Flying Qualities Report Volume III: Power Approach Flying Qualities – Flight Test Basis, Boeing-STL 99A0070, Volume III, Revision A, of 31 Jan 2001, pp. 78-82.
96. NAVAIRTESTCEN Technical Report No. SA-7R-80, Initial Shipboard Trials (IST) of the F/A-18A Airplane, of 1 Feb 1980, p. 11.
97. RHE-NAV-90-TR1, Outer-Loop Control Factors for Carrier Aircraft, Heffley, Robert K., of 1 Dec 1990, p.49.
98. NAVAIRTESTCEN Report No. FT2122-015, of 6 Dec 1963, p.44.
99. NAVAIRTESTCEN Report No. FT-93R-70, BIS A-7E-03, Phase 2 FQ&P, of 12 Oct 1970, p. 62.
100. NAVAIRTESTCEN Report No. FT-49R-68, BIS 21268, FQ&P Trials of the F-4J, of 26 Jul 1968, p. 61.
101. NAVAIRTESTCEN Report No. FT-74R-75, S-3A FQ&P, of 12 Mar 1975, p. 71.
102. NAVAIRTESTCEN Report No. FT-09R-72, Phase IIA Navy Preliminary Evaluation of the F-14A Airplane, of 6 Dec 1972.
103. NAVAIRTESTCEN Report No. SA-121R-82, F/A-18A Airplane Carrier Suitability Navy Technical Evaluation (TECHEVAL), Fourth Interim Report, of 11 Apr 1983.

104. NAVAIRTESTCEN Report No. FT-04R-68, Preliminary Carrier Evaluation of Model F-111B Airplane, of 21 Aug 1968.
105. NAVAIRTESTCEN Report No. FT-139R-69, Carrier Suitability Evaluation of the RA-5C Airplane with ECP-260A Incorporated, of 9 Dec 1969.
106. NAVAIRTESTCEN Report No. FT-15R-69, Project BIS 21277 Carrier and Advanced Airfield Aircraft Performance Trials of the F-8J of 13 Feb 1969.
107. "S-3A Guaranteed Performance Substantiation", Lockheed Aircraft Corporation, LR25100 Addendum 1, of 7 Sep 1973.
108. NAVAIRTESTCEN Report No. SA-80R-89, Developmental Testing and Evaluation of Phase IIA (DT-IIA) of the T-45A Aircraft, Final Report, of 15 Mar 1990.
109. NAVAIRTESTCEN Report No. SA-127R-90, F-14A (PLUS) Aircraft/Ship Compatibility, of 27 Aug 1991.
110. NAVAIRTESTCEN Report No. SA-50R-92, Flight Test Evaluation of the F404-GE-402 Enhanced Performance Engine in the F/A-18 Airplane, of 18 May 1993.
111. NAVAIRTESTCEN Report No. FT35-526, BIS 21226, Carrier Suitability Trials of Model T-2J Airplane, Report No. 1, Final Report of 10 Dec 1959.
112. NAVAIRTESTCEN Report No. FT-1R-71, Phase 1A Flying Qualities and Carrier Suitability Follow-on Navy Preliminary Evaluation of the A-4M Airplane, of 11 Jan 1971.
113. AGARD Report 567, "The Use of Pilot Rating in the Evaluation of Aircraft Handling Qualities", Cooper, G.E. and Harper, R.P., of Apr 1969.
114. AIAA-86-2251-CP, Terminal Control Factors for the Carrier Landing Task, Heffley, R. K., of Aug 1986.
115. Hynes, S. and Pandelaras, C., PA Roll Performance Criteria Investigation, Presentation at the Flight Dynamics Working Group, NASA Langley, Feb 28 1996.
116. Systems Technology Report STI-TR-190-1, Outsmarting MIL-F-8785B(ASG) the Military Flying Qualities Specification, of Aug 1971, p. 6.
117. AFFDL-TR-78-154, Handling Quality Requirements for Advanced Aircraft Design: Longitudinal Mode, Smith, Ralph H., and Geddes, Norman D., of Aug 1979, p.140.
118. A Review of the Flight Characteristics of the F4D-1 and F7U-3 Aircraft with Particular Emphasis on Carrier Suitability, KLD Associates, of 7 Jul 1986, pp. 9-10.

119. Air Force Systems Command, Technical Report No. ASD-TR-78-13, USAF Flying Qualities Requirements for a STOL Transport, Gerken, Gary. of Mar 1977.
120. Anonymous, Aeronautical Design Standard ADS-33D, Handling Qualities Requirements for Military Rotorcraft, U. S. Army Aviation and Troop Command, St. Louis, MO, of Jul 1994.
121. NAVTRAEQUIPCEN Technical Report No. 80-C-0063-2, Pilot Behavior Models for LSO Training Systems, Hooks, J. Thel and William S. McMurry, of Oct 1983.
122. FAA-RD-74-179 I (NASA-TMX-62,395), A STOL Airworthiness Investigation Using a Simulation of an Augmentor Wing Transport, Stapleford, Robert L. et al; of Oct 1974.

GLOSSARY

a	Angle of Attack
θ	Pitch Attitude
?	Ambient Density
ACLS	Automatic Carrier Landing System
AIAA	American Institute of Aeronautics and Astronautics
AOA	Angle of Attack
AOB	Angle of Bank
APC	Approach Power Compensation
ARB	Aircraft Recovery Bulletin
BLC	Boundary Layer Control
BUAER	Bureau of Aeronautics
BUWEPS	Bureau of Weapons
CAC	Carrier Approach Criteria
CCA	Carrier Controlled Approach
CDP	Cross-Desk Pendants
CG	Center of Gravity
CHR	Cooper Harper Rating
CLDGW	Carrier Landing Design Gross Weight
C_L	Lift Coefficient
C_{Lmax}	Maximum Lift Coefficient
CV	Aircraft Carrier, Carrier Variant
DEP	Design Eye Position
DLC	Direct Lift Control
DoD	Department of Defense
DOF	Degree of Freedom
EMCON	Emergency Condition
FADEC	Full Authority Digital Engine Control
FCLP	Field Carrier Landing Practice
FCLS	Flight Control Limit Speed
FQ	Flying Qualities
FLOLS	Fresnel Lens Optical Landing System
FOD	Foreign Object Damage
FOV	Field of View
FPA	Flightpath Angle
H/E	Hook-to-Eye
H/R	hook-to-ramp
HUD	Head-up Display
IFLOLS	Improved Fresnel Lens Optical Landing System
IFPC	Integrated Flight and Propulsion Control
ILS	Instrument Landing System
IMC	Instrument Meteorological Conditions
INS	Inertial Navigation System
IPT	Integrated Product Team
JMS	Joint Model Specification

GLOSSARY (cont'd)

JSF	Joint Strike Fighter
JSFPO	Joint Strike Fighter Program Office
JSSG	Joint Service Specification Guide
KPP	Key Performance Parameter
LEX	Leading Edge Extension
LS	Landing Speed
LSO	Landing Signal Officer
MAC	McDonnell Aircraft Corporation
MDA	McDonnell-Douglas Aircraft
MIL	Military Rated Thrust
MNS	Mission Needs Statement
MOVLAS	Manual Optical Visual Landing Aid System
NACA	National Advisory Committee for Aeronautics
NASA	National Aeronautics and Space Administration
NATC	Naval Air Test Center
NATOPS	Naval Air Training and Operating Procedures Standardization
NAVAIRSYSCOM	Naval Air Systems Command
NSC	Naval Safety Center
Nz	Normal Load Factor
OLS	Optical Landing System
ORD	Operational Requirement Document
OSD	Office of the Secretary of Defense
PA	Powered Approach
PMA	Program Manager – AIR
RF	Radio Frequency
RFP	Request for Proposal
RHW	Recovery Head Wind
R/C	Rate of Climb
R/D	Rate of Descent
RO	Requirements Officer
SC	Service Change
SDD	System Development and Demonstration
SME	Subject Matter Expert
S/MTD	F-15 Short Takeoff and Landing/Maneuvering Technology Demonstrator
STOVL	Short Takeoff and Vertical Landing
TEU	Trailing Edge Up
T/W	Thrust-to-Weight Ratio
UAV	Unmanned Aerial Vehicles
UK	United Kingdom
USAF	United State Air Force
USMC	United States Marine Corps
USN	United States Navy
USNTPS	United States Test Pilot School

GLOSSARY (cont'd)

V	Velocity
V_{Dmin}	Velocity at Minimum Drag
V_{HPmin}	Velocity at Minimum Power
VAX	Experimental Light Attack Aircraft, later designated A-7
VFAX	Fighter Attack Experimental Aircraft
VFR	Visual Flight Rules
VLA	Visual Landing Aid
V_{mc}	Minimum Controllable Airspeed
VMC	Visual Meteorological Conditions
V_{pa}	Carrier Approach Speed (Velocity – Power Approach Configuration)
$V_{pa_{min}}$	Minimum Approach Speed
V_{SPilot}	Stall Speed as Reported by Aircrew
V_s	Stall Speed
VSI	Vertical Speed Indicator
V_{SCLmax}	Stall Speed at Maximum Lift Coefficient (Aerodynamic Stall)
V_{SL}	Stall Speed in the Landing Configuration
V_{Spa}	Stall Speed in Configuration Power Approach
W	Weight
WOD	Wind Over Deck
WSS	Weapon System Specification

THIS PAGE INTENTIONALLY LEFT BLANK

APPENDIX A
CARRIER APPROACH CRITERIA STUDY TEAM MEMBERS

Naval Air Systems Command		
Mr. Thomas G. Rudowsky	Study Team Co-leader	Head, Flight Vehicle Performance Branch (AIR4322)
Mr. Stephen P. Cook	Study Team Co-leader	Flight Dynamics Branch (AIR4324)
Mr. Marshall Hynes	Study Team Co-leader	Flight Dynamics Branch (AIR4324)
Mr. Tom Lawrence	Team Member	Aeromechanics Division Staff (AIR432)
Mr. Michael Caddy	Team Member	Aeromechanics Division Staff (AIR432)
Mr. Douglas Bollman	Team Member	JSF/Flight Vehicle Performance Branch (AIR4322)
Mr. Hugo Gonzalez	Team Member	Flight Vehicle Performance Branch (AIR4322)
Mr. William Schork	Team Member	Flight Vehicle Performance Branch (AIR4322)
Mr. Buddy Denham	Team Member	Flight Controls Branch (AIR4325)
Mr. Page Senn	Team Member	Carrier Suitability Branch (AIR4K)
Mr. Eric Ryberg	Team Member	JSF/Carrier Suitability Branch (AIR4K)
LCDR Chris McCarthy	Team Pilot	Carrier Suitability
LT Matt Paradise	Team Pilot	Carrier Suitability
LCDR Jack Waters	Team Pilot	Carrier Suitability
United States Naval Academy		
Capt Robert Niewohner, Ph.D.	Team Pilot	Chairman, Aerospace Engineering
Virginia Polytechnic Institute and University		
Dr. Wayne "Bull" Durham	Team Member	Aerospace Engineering
Consultants		
Mr. Melvin Luter	Team Member	Consultant, Retired NAVAIRSYSCOM Head, Flight Vehicle Performance Branch
Mr. Al Sonntag	Team Member	Consultant, Retired Boeing F/A-18 Aerodynamics Team Leader
Mr. Robert Heffley	Team Member	Consultant, Robert Heffley Engineering
Boeing		
Mr. Henry Beaufreere	Team Member	Boeing
Mr. Fred Harris	Team Member	Boeing
Mr. Bret Marks	Team Member	Boeing
Lockheed-Martin		
Mr. Eric Gull	Team Member	Aerodynamics
Mr. Brian Kiger	Team Member	Configuration Design
Mr. Russ Killingsworth	Team Member	Stability and Control
Mr. Brian Losos	Team Member	Air Vehicle Performance
Mr. John McCune	Team Member	X-35 Flight Controls
Mr. Art Sheridan	Team Member	Aero Technologies
Ms. Sibille Tallant	Team Member	Flight Controls
Mr. Mark Tibbs	Team Member	Flight Controls
Mr. Joe Sweeney	Team Member	X-35 Project Pilot
Mr. Steve Weatherspoon	Team Member	Navy Business Development
Mr. Dave Wyatt	Team Member	Flight Controls
Mr. Michael Yokell	Team Member	Basing and Ship Suitability

THIS PAGE INTENTIONALLY LEFT BLANK

APPENDIX B
JOINT SERVICE SPECIFICATION GUIDE GROUND RULES FOR THE
CARRIER APPROACH CRITERIA

JOINT SERVICE SPECIFICATION GUIDE GROUND RULES FOR APPROACH SPEED

From Appendix D of the JSSG:

Glide Slope Transfer (Popup) Maneuver

The lowest speed at which the aircraft is capable of making a glide path correction from stabilized flight to a new glide path 50 feet above the original glide path within five (5) seconds after initiation of the maneuver. The maneuver shall be performed without change in thrust settings by the pilot, and the aircraft angle of attack during the maneuver shall not exceed that necessary to achieve 50 percent of the maximum positive delta lift available, based on static lift coefficient, at the initiation of the maneuver. Control rate input for simulation of V_{pa} shall not exceed control system limits. The maneuver shall be considered complete when a glide path correction of 50 feet has been reached. After completion of this maneuver, the aircraft shall be capable of maintaining a new glide path at least 50 feet above and parallel to the initial glide path, with the pilot permitted to change thrust setting as required.

Field-of-View (Vision)

The lowest level flight speed at which the pilot, at the DEP, can see the stern of the carrier at the waterline when intercepting a 4° optical glide slope at an altitude of 600 feet. The origin of the glide slope is 500 feet forward of the stern and 63 feet above the waterline.

Level I FQ

The lowest speed at which all stability and control requirements are satisfied (MIL-STD-1797).

Stall Margin

110 percent of the power-on stall speed using the thrust (power) required for level flight (V_{spa}) at 115 percent of V_{sl} , the power-off stall speed in the landing configuration.

Flight Control Limit Speed

The minimum speed based on flight control limiting with margins applied as appropriate, subject to the approval of the procuring activity.

Large Throttle Response (Longitudinal Acceleration)

The lowest speed at which it is possible to achieve a level flight longitudinal acceleration of $.155\text{ g}$ (5 ft/sec^2) within 2.5 seconds after initiation of throttle movement and speed brake retraction.

Small Throttle Response

To insure rapid aircraft response to step throttle commands corresponding to $\pm 0.120\text{ g}$ ($\pm 3.86\text{ ft/sec}^2$) longitudinal acceleration, such throttle inputs shall result in achieving 90 percent of the commanded acceleration within 1.2 seconds. This requirement shall apply in the approach configuration throughout the range of all throttle settings required for operations over the usable approach configuration weight/drag levels while trimmed on a 4° glide slope.

JOINT SERVICE SPECIFICATION GUIDE GROUNDRULES FOR WAVEOFF

From Appendix D of the JSSG:

D.3.8.2.2.2 Waveoff. Waveoff is defined as an aborted landing attempt during which the aircraft does not touchdown. Waveoffs are divided into two categories: on glide slope, or above glide slope, depending on the aircraft's position when the waveoff is initiated.

a. Initial conditions for waveoff are:

1. On glide slope. The aircraft will be on a 4° optical glide slope stabilized at V_{pa} and α_{pa} . Thrust will be as required to meet this flight condition. With a 0.7 second delay to account for pilot reaction time when the waveoff signal is displayed, the throttles are advanced to Intermediate/Maximum rated thrust (power), and speed brake (if used) retraction is initiated.
2. Above glide slope. This condition is intended to represent the most severe environment for a waveoff. It reflects a gross glide slope correction from a high (1 ball) position. The aircraft will be on a $4^\circ 20.45''$ optical glide slope stabilized at V_{pa} and α_{pa} . Thrust will be as required to meet this condition. The throttles are advanced to Intermediate thrust (power) and speed brake (if used) retraction is initiated.

b. The following criteria must be met for both categories for a waveoff to be considered acceptable:

1. A time to zero sink speed not greater than 3.0 seconds with a longitudinal acceleration of 3.0 kts/sec on a 89.8° F day.
2. Controllable change, if required, shall not go beyond $0.9 C_{L_{max}}$.
3. Level I flying qualities as defined by MIL-STD-1797 shall be maintained during all aspects of the waveoff.
4. Engine spool up characteristics must be considered.

c. The following techniques are options for both categories:

1. The maneuver shall be flown at constant α with increasing θ . This is the preferred technique.
2. The maneuver shall be flown at constant θ with decreasing α .
3. The maneuver shall be flown with simultaneous aircraft rotation (α and θ) and throttle advancement. α shall increase by no more than 3° .

The maneuver is complete after positive rate-of-climb has been achieved.

JOINT SERVICE SPECIFICATION GUIDE GROUNDRULES FOR BOLTER

From Appendix D of the JSSG:

D.3.8.2.2.4 Bolter. Bolter is defined as a missed wire landing attempt in which the aircraft touches down and then power is applied for a takeoff. It applies to both carrier landing operation and field carrier landing practice. The term bolter performance is used to denote the distance from landing touchdown to liftoff from a carrier/field.

D.3.8.2.2.4.1 Computational Ground Rules. The initial conditions and criteria used in the computation of bolter shall be as follows:

a. The initial conditions of bolter are:

1. The aircraft will be on a 4° optical glide slope stabilized at V_{PA} and α_{PA} with the engine(s) stabilized at Flight Idle thrust (power) and the arresting hook point 6 inches above the landing surface.
2. Throttles shall be advanced to Intermediate/Maximum thrust (power) 0.5 seconds after the main landing gear touch down.
3. Longitudinal control inputs are to be made 1.0 seconds after touchdown to attain the desired fly-away attitude.

b. The following criteria must be met for a bolter to be considered acceptable:

1. The AOA during fly-away shall be between α_{pa} and α_{pa} plus 3° but shall not go beyond $0.9 C_{Lmax}$.
2. Level I flying qualities as defined by MIL-STD-1797 shall be maintained during all aspects of the waveoff.
3. Engine spool up characteristics must be considered.
4. Thrust arrestment reduction system logic, if utilized, is reflected during the maneuver.

The maneuver is complete when the aircraft CG has achieved an altitude 50 feet above the landing height.

THIS PAGE INTENTIONALLY LEFT BLANK

APPENDIX C
SHORT- TERM FLIGHTPATH RESPONSE CRITERIA INVESTIGATIVE EFFORT

List of Figures

<u>Figure No.</u>	<u>Title</u>	<u>Page No.</u>
C-1	Profile of the Carrier Approach Task.....	166
C-2	Partitioned Model of Longitudinal Aircraft Dynamics.....	168
C-3	United States Naval Test Pilot School Simulator	170
C-4	Simulink Model of Aircraft Equations of Motion	172
C-5	Pilot Opinion as a Function of Flightpath Response Lag	175
C-6	Pilot Opinion as a Function of Closure Speed	175
C-7	Summary of Results from Test Pilot School Carrier Approach Simulation.....	176
C-8	Glide Slope Error Measured for Three Approaches	177
C-9	Glide Slope Error following a Forced Offset.....	177

List of Tables

<u>Table No.</u>	<u>Title</u>	<u>Page No.</u>
C-1	USNTPS Simulation Description	171
C-2	Initial Test Matrix	173

BACKGROUND

Because of the questions surrounding the relevancy and adequacy of the GS transfer criterion, an investigative effort was launched to explore alternate ways of specifying adequate flightpath response.

The investigation of flightpath control-related criteria focuses on those metrics, existing and potential, that give an aircraft design the necessary attributes to approach and land aboard a CV under manual or automatic control with conventional guidance and visual cues.

In general, control criteria can apply to several aspects of a system, including short-term response, control power, damping, delay, cross coupling, and other relevant features. The philosophy of current CV approach design criteria is not to address all such features in detail, but rather to focus on those most critical and urgent early in the design process.

Of the current array of CV approach design criteria, there has not been an explicit requirement for a minimum level of short-term flightpath response. That is, there is no criterion that provides a direct minimum level of how aggressively the pilot can track the GS guidance either from the FLOLS or from an electronic GS indication. Some existing criteria such as the popup maneuver, flightpath stability (dy/dV), and longitudinal acceleration appear to address flightpath control, but none set an explicit level of short-term response that would dictate a minimum control bandwidth appropriate to the task. Reference 37 allows for specification of a flightpath response, but no value is presently defined or recommended.

One problem that a short-term flightpath response criterion would address is the ability to make sufficiently rapid corrections in GS error within the limits inherent in the final approach to the CV as shown in figure C-1. Useful FLOLS guidance begins at a range of approximately $\frac{3}{4}$ nm from the CV. All path corrections must be successfully completed and a steady state achieved no closer than about 1,000 ft from touchdown. This crucial task requirement lacks any explicit requirement of aircraft performance or maneuverability.

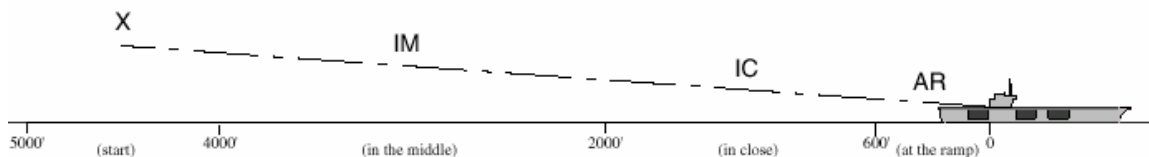

Figure C-1: Profile of the CV Approach Task

The investigative effort conducted for this study, employing both analysis and manned simulation, is intended to gather data to support a systematic examination of candidate metrics and criteria. While there are several design features that contribute to short-term flightpath control, some have greater importance than others and some are already addressed by existing design criteria. For example, there is a criterion for short-term response of small amplitude longitudinal acceleration. This impacts thrust response, one possible component of flightpath response. But thrust response alone may not guarantee the level of path response. Some experimental data are presented in reference 97 and a

detailed analytical treatment is given in reference 113. These sources combined give a basis for selecting the most influential parameters with respect to short-term flightpath control.

FOCUS

The focus of this investigation is to gain insight into the design features that determine overall flightpath response. Pitch and thrust response support flightpath (and AOA) control, but the main contributors are normally airframe lift and drag aerodynamics. Very large aerodynamic forces are needed to rapidly modulate the vertical position of the aircraft and to provide the damping needed to settle commanded responses. Should the designer choose to use propulsive forces to accomplish the task, a similar large magnitude of force is required.

Analyses point to at least two characteristics crucial to flightpath control response that are not presently bounded by explicit criteria: (1) airframe heave damping and (2) effective inclination of modulated thrust with respect to the direction of flight. These two characteristics were selected as the initial subjects of investigation in a manned fixed-base simulation of the CV approach and landing task. While other characteristics warrant examination during this study, the above-mentioned two are particularly compelling. Not only do they determine the predominant quickness and quality of flightpath response, both must be set early in the design process and are fundamentally difficult to modify. Heave damping is dependent upon wing loading and wing aspect ratio, and thrust inclination is set by engine and nozzle installation or by auxiliary propulsion devices. Appropriate design criteria give the designer the authority to set such characteristics without undue compromise. Furthermore, some criteria now considered as addressing flightpath control, most notably the popup maneuver, may eventually be better understood and either be relegated to more valid roles or be discounted altogether.

OBJECTIVES

The first objective of this investigative effort is to find one or more explicit criteria that set a lower bound on the short-term flightpath response in the context of the CV landing task. It is desirable that such criteria be rational and based on a clear understanding of the physics and human pilot factors involved in the CV landing.

An important supporting objective is to also develop an understanding of the CV approach task and its implications for bounding aircraft response. This understanding can be achieved by a combination of analysis of system dynamics, experimental efforts involving experienced pilots, and measurement and analysis of actual CV landing operations where feasible.

SYSTEM MODEL

The system model is constructed in such a way to facilitate the cataloging and prioritization of the various features and metrics that relate to flightpath control. This is accomplished using a physical system model that includes the aerodynamic, propulsion, and control system components. However, this model is fashioned in a way that aids in tracking cause and effect. To the extent possible, the individual model parameters represent specific response characteristics. Matlab and Simulink were used to produce the system model. Matlab is a widely used engineering analysis software suite that

aids in describing and analyzing systems, in this case, aircraft dynamics. Simulink is a related software tool that permits easy simulation of systems using block diagrams and graphical interfaces.

Figure C-2 shows a useful way of partitioning the aircraft equations of motion simplifying the relationships among airframe, flight controls, and engine components. This model carries all the important first-order features while ignoring some lesser characteristics. It imbeds the controls (engine and flight control system) in the two leftmost blocks, the airframe in the center, and the controlled variables in the two rightmost blocks. Each can thus be treated independently in reasonably simple terms, and there is a clear audit trail between cause and effect.

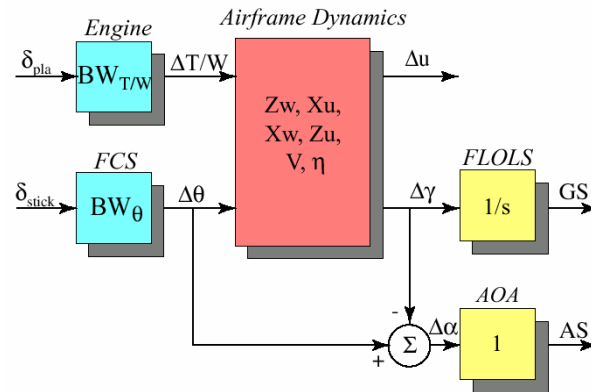

Figure C-2: Partitioned Model of Longitudinal Aircraft Dynamics.

CONTROLS

Beginning at the left side of figure C-2, the engine and flight control system blocks are viewed in terms of their respective bandwidths. In the simplest terms, the engine is described as a first- or second-order lag. Similarly, the attitude response also is described in terms of its bandwidth, whether its response type is a rate system, an attitude system, or something intermediate. The bandwidth in either case is simply how tightly (aggressively) the pilot (or any other controller) could actively regulate the output. Bandwidth is the frequency below which the phase margin is at least 45 deg or the gain margin is at least 6 dB. As such, there is the ability to achieve good closed-loop control with a level of aggressiveness equivalent to the bandwidth value.

The pitch and thrust components are intentionally factored out of the airframe because they need to be viewed in a supporting role. The bandwidth of each must be substantially higher (by a factor of 2 or 3) than that of the airframe and overall flightpath response in order to maximize the airframe response. At the same time, contemporary aircraft designs typically enjoy reasonably quick responses in pitch and thrust as a result of well-engineered digital control system design. Therefore, we emphasize the airframe component in these investigative efforts.

AIRFRAME

In the center of figure C-2 is the airframe response having inputs of incremental normalized thrust (incremental thrust-to-weight ratio) and incremental attitude. The output states of the airframe are incremental (relative to trim), airspeed (or AOA), and FPA. The relationships between inputs and

output are a simple 2-DOF set of equations with six parameters: four stability derivatives, true airspeed, and the effective inclination of the thrust vector with respect to the trim airspeed vector.

In terms of a simple matrix form, the airframe response is:

$$\begin{bmatrix} \Delta \dot{u} \\ V \cdot \Delta \dot{\mathbf{g}} \end{bmatrix} = \begin{bmatrix} X_u & -X_w \\ -Z_u & Z_w \end{bmatrix} \cdot \begin{bmatrix} \Delta u \\ V \cdot \Delta \mathbf{g} \end{bmatrix} + \begin{bmatrix} g \cdot \cos \mathbf{h} & (X_a - g) \\ g \cdot \sin \mathbf{h} & -Z_a \end{bmatrix} \cdot \begin{bmatrix} \Delta T/W \\ \Delta \mathbf{q} \end{bmatrix}$$

Given the fact that X_α and Z_α are functions of X_w and Z_w , i.e.,

$$\begin{aligned} X_a &= V \cdot X_w \\ Z_a &= V \cdot Z_w \end{aligned}$$

The airframe equations of motion really contain only the variables Z_w , X_u , X_w , Z_u , V , and η . This limits the number of parameters that merit examination with respect to the airframe. The list can be further limited by studying the actual response features that the above equations yield. Further definitions of stability derivatives and other parameters are given in reference 97. However the main two characteristics, Z_w and η , should be emphasized here.

The dimensional stability derivative Z_w is a close approximation to flightpath bandwidth for any type of applied force, including pitch, thrust, or DLC. As shown by the following expression, heave damping is proportional to the lift curve slope and inversely proportional to wing loading.

$$Z_w = -\frac{\mathbf{r}VS(C_{L\alpha} + C_D)}{2m}$$

The parameter η refers to the effective thrust inclination acting through the CG relative to the trim velocity vector. It is the resultant of the x and z -force vectors for small changes in power lever about the trim point. Although the thrust centerline may be aligned with the fuselage reference line (as it is in the F-18), there would still be a positive thrust inclination equal to the trim AOA.

CONTROLLED VARIABLES

The primary controlled variables for the CV approach are position relative to GS, AOA relative to target value (AS), and lineup position relative to angled deck centerline (LU). (AS refers to airspeed although the actual variable monitored and regulated by the pilot is AOA. This is an LSO convention that can be found in reference 121.) The longitudinal controlled variables are shown as outputs of the two rightmost blocks in figure C-2. AOA is given explicitly as the difference of pitch attitude (control) and FPA (state variable). GS angle is the integral of FPA with respect to time as shown by the $1/s$ Laplace operator.

Note that control of GS error is not equivalent to control of FPA. The additional integration adds 90 deg of phase lag. While the pilot might be able to rapidly command and settle a change in FPA, a stabilized change in position relative to GS would take a substantially longer time.

DESCRIPTION OF SIMULATOR EXPERIMENT

The experiment was performed at USNTPS from February to June 2001. It is an ideal facility for initial studies because of its manageability, capability for simulating a CV approach task, and access to carrier-experienced test pilots.

SIMULATOR FACILITY

The simulator facility consists of a simple fixed-base cockpit with a three-window display of the CV approach with a HUD superimposed on the center window (figure C-3). The cockpit contains force-feedback control loaders for the center stick and throttle. Engine sound provides the pilot with a cue for use of throttle. The simulator math model interface accommodates a Simulink model. Technical specifications of the USNTPS simulator are found in table C-1.



Figure C-3: USNTPS Simulator

Table C-1: USNTPS Simulation Description

- **Control Loading:**
 - Longitudinal stick with break-out of 1 lb and linear gradient of 0.31 lb/in.
 - Throttles with friction of 5 lb

- **Visual System:**
 - 60 Hz noninterlaced
 - Textured model of CV with FLOLS and drop lights
 - FOV – Three monitors of 27 deg by 30 deg each (Total Horizontal ± 45 deg, Total Vertical ± 15 deg)
 - Resolution (Center Monitor 1280 x 1024, Side monitors 640 x 480)
 - FLOLS (Proportional beam width ± 0.8 deg, scaling increased as needed for pilot use)
 - HUD parameters
 - (E-bracket and Flightpath Marker, digital airspeed, altitude and AOA)

- **Audio of engine RPM**

SIMULATOR MODEL

The aircraft model consists of a linear stability derivative formulation that idealizes the attitude and heading dynamics and permits selective variation of basic flightpath and airspeed dynamics. Pitch and roll axes consist of a rate-command response type. The throttle commands an incremental change in thrust-to-weight. The model parameters are precomputed to represent operation about a selected airspeed (or AOA).

Figure C-4 shows the Simulink block diagram that portrays the above system.

thrust inclination influences the speed control characteristics in terms of cross coupling between pitch and thrust inputs.

Table C-2 shows the 20 configurations that were used as an initial exploration of flightpath control characteristics. This matrix explores a covariation in heave damping, Z_w , and thrust inclination, η . The ranges represent a large range of design configurations.

Table C-2: Initial Test Matrix

	-0.5 rad/sec	-0.35 rad/sec	-0.2 rad/sec	-0.1 rad/sec
Z_w:	(deg)	(deg)	(deg)	(deg)
η:	0	0	0	0
	10	10	10	10
	25	25	25	25
	45	45	45	45
	75	75	75	75

(The baseline case is highlighted.)

A contemporary design such as the F-18 is approximately equivalent to a Z_w equal to about -0.35 rad/sec and a thrust inclination of about 10 deg. Reduction in heave damping to the -0.1 rad/sec level corresponds to a very high wing loading and low-aspect-ratio planform. An increase in thrust inclination to 75 deg gives the pilot the ability to control flightpath with throttle alone and with minimal upset to airspeed. A high-thrust inclination configuration could result from using aerodynamic DLC blended with thrust, an auxiliary vertically-inclined propulsion unit, or a vectored nozzle.

Upon making the above covariation in Z_w and η , the next priorities are to examine the secondary effects of control bandwidth (pitch and thrust), back-sidedness, and closure speed. This is important for judging the relative importance of parameters.

PROCEDURE

The baseline task is a final approach to the CV beginning with a choice of small offsets from the final leg and ending at the deck. The three initial offsets consist of:

IC #1: Alt = 600 ft, Range = 2.0 nm from ship, level flight, LUL, onspeed, low; about 60 sec time in groove.

IC #2: Alt = 260 ft, Range = 0.7 nm from ship, level flight, onspeed, high, 10 deg heading angle; about 18 sec time in groove.

IC #3: Same as IC #1 with a step altitude change of height H_s at distance R_s from the boat.

An estimate of successful arrestment is made by viewing the axial position at deck contact.

After beginning the baseline task (rolling out and stabilizing on final) it is useful to have the pilot make corrections in GS error and airspeed (AOA) in a systematic way that can be measured and analyzed. One procedure for doing this is to apply a step to the displayed error in GS. It is then up to the pilot to respond with an appropriate correction.

One benefit of forced corrections is the ability to apply pilot identification techniques in order to extract an effective crossover frequency for the GS task. This gives us a quantitative measure of aggressiveness for the outermost control loop. The crossover frequency can be compared directly to the inherent bandwidth available using the known airframe, attitude, and thrust control dynamics.

RESULTS OF THE INVESTIGATIVE EFFORT

The following is a brief description of results from the investigative effort as well as from results from related earlier studies.

PRIOR RESEARCH

There are previous studies of short-term flightpath response that relate to the present investigative efforts. The results of these earlier studies are not conclusive by themselves due to a combination of insufficiency of data, lack of simulator fidelity, and difference in task context. Nevertheless, they support the emphasis on short-term flightpath response and technical approach being taken here.

The main theme of the present effort is to examine the need for a minimum level for short-term flightpath response such as a minimum bandwidth criterion. This kind of requirement was suggested for powered-lift STOL transport aircraft based on a series of simulator studies. Experimental data were collected using the NASA Ames FSAA large-amplitude lateral motion simulator and initially reported in reference 122.

A subsequent simulation of the CV approach task focused on flightpath response in terms of an effective lag time constant (the inverse of heave damping or bandwidth). The simulator was a fixed-

base cab with a camera terrain database. Data are presented in reference 97. Figure C-5 shows the general relationship between this lag parameter and pilot rating.

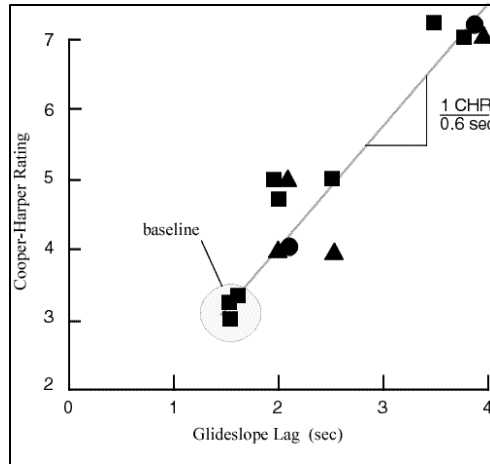

Figure C-5: Pilot Opinion as a Function of Flightpath Response Lag

The same simulation included a variation in closure speed without changing aircraft path response. Figure C-6 shows the effect on pilot rating with closure speed for the CV approach task while maintaining a baseline value of flightpath response lag (1.5 sec).

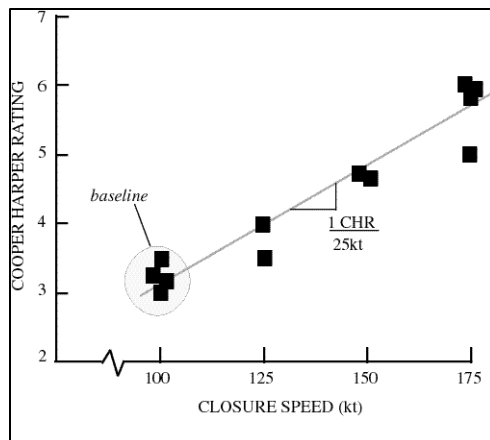

Figure C-6: Pilot Opinion as a Function of Closure Speed

TEST PILOT SCHOOL FIXED-BASE SIMULATION

The USNTPS fixed-based simulator experiment is presently yielding preliminary results that indicate the effects of heave damping and effective thrust inclination on pilot opinion ratings for the CV approach task.

Figure C-7 shows pilot opinion (Cooper-Harper) ratings over broad ranges of heave damping and effective thrust inclination. The primary pilot task was defined as obtaining a successful arrestment. The desired performance was defined as capture of the 2 or 3 wire; acceptable performance was

capture of the 2, 3 or 4 wire. The secondary tasks were to maintain GS, airspeed, and lineup within the following thresholds:

- GS - Desired: Maintain GS $\pm 1/2$ cell; Adequate: Maintain GS ± 1 cell.
- Airspeed – Desired: Maintain AOA within $\pm 1/2$ deg (within E-bracket); Adequate: Maintain AOA within ± 1 deg (i.e., no large E-bracket excursions).
- Lineup - Desired: Maintain runway centerline ± 5 ft; Adequate: Maintain runway centerline ± 10 ft.

The following important general trends can be seen:

- a) Some level of thrust inclination greater than zero is important in this task.
- b) For generally horizontal thrust configurations (say, $\eta = 10$ deg), there is a benefit from higher heave damping.
- c) Increasing thrust inclination is desirable and appears to eliminate the need for heave damping.
- d) With sufficiently high heave damping, there is no benefit from increasing thrust inclination.

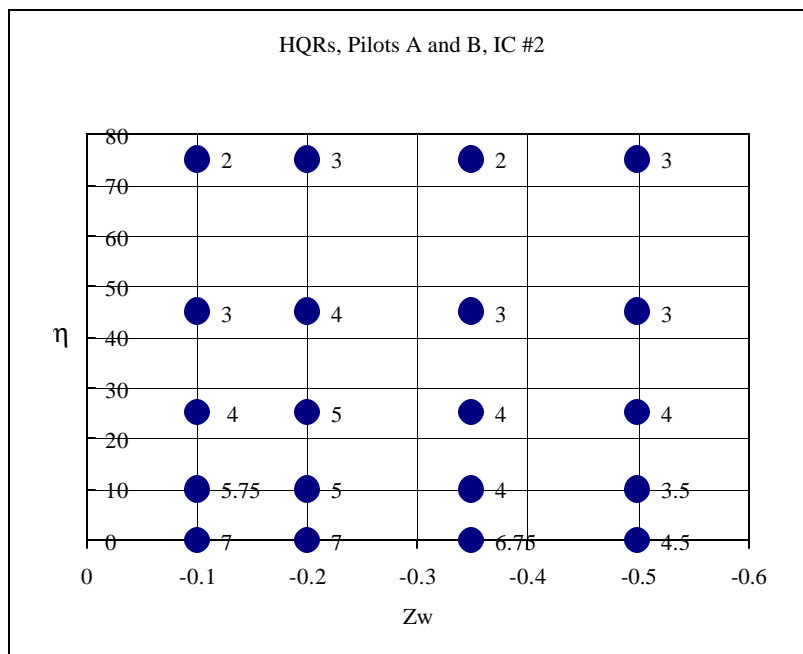

Figure C-7: Summary of Results from USNTPS Carrier Approach Simulation

However, the following factors must be considered. First, only trends should be recognized and not the absolute pilot rating values; results are based on fixed-base simulation with no in-flight verification. Second, the apparent benefit of large thrust inclination may not hold if the thrust

increment is control-power-limited. Also, if the thrust is offset from the CG, there could be a blended pitch and thrust effect that would affect ratings.

Data from selected individual runs are examined in order to gain an understanding of how many discrete flightpath corrections are typically made during an approach. Figure C-8 shows three runs starting at 4,000 ft range with a configuration and closure speed resembling the F-18. Preliminary results indicate that there may not be more than only one significant correction following the GS capture.

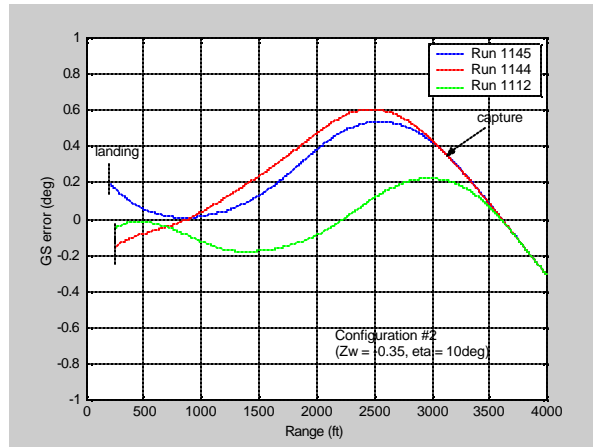

Figure C-8: GS Error Measured for Three Approaches

Figure C-9 shows the recovery from a forced offset occurring at 2,500 ft range. Note that the recovery requires a distance of 1,500 to 2,000 ft and is not well damped.

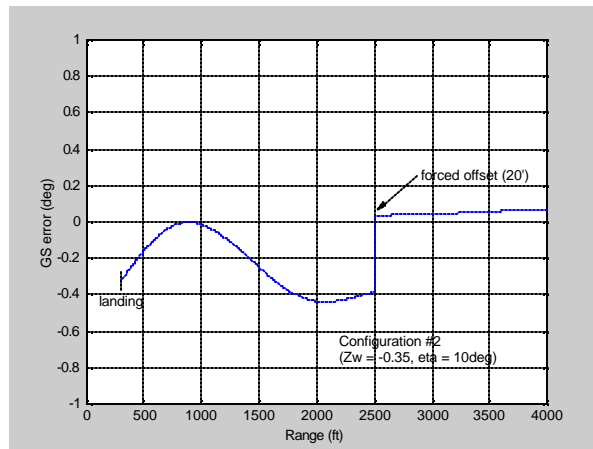

Figure C-9: GS Error following a Forced Offset

By analyzing the time histories of the forced offset tasks, the distance required for GS corrections can be determined and compared to the configuration wavelength representing the correction capability. Final analysis results were not available for this report. However, the data clearly indicate that there are yet unbounded flightpath response characteristics (such as heave damping and thrust

inclination) that strongly affect the pilot's ability to perform the CV landing task. This suggests a need for appropriate criteria.

CONCLUSIONS

As reported in Chapter 7, the conclusions from the experiment are as follows.

General

Using the technical approach and measurement techniques employed in the USNTPS simulation, several factors relating to the CV approach task can be successfully evaluated.

At the same time, we need to: (a) adjust some math model features (e.g., the need for AOA stability), (b) tune measurement tools (e.g., distance and amplitude of step disturbances to GS error), and (c) streamline the test matrix.

It is feasible and advantageous to use a "plug-in" simulator math model based on Matlab/Simulink tools. This permits the portability of the math model to other simulator facilities without major reprogramming and allows offline analysis of the vehicle characteristics.

Specific

Heave damping and effective thrust inclination are two sensitive airframe design parameters.

- a) Both characteristics influenced pilot ratings and comments over wide ranges.
- b) In general, pilots preferred higher thrust inclination angles. This may be an indicator of the desire for rapid thrust response on GS.
- c) Pilots found that larger amounts of heave damping improved task performance at low thrust inclination angles. At thrust inclination angles of 25 deg or greater, there was little to no correlation with the level of heave damping.

Evaluation pilots produced useful comments regarding pilot technique (use of throttle and pitch-attitude controls).

- a) Qualitative pilot comments and ratings indicate that pilots desire that the flightpath change rapidly with throttle input and that minimal correction to airspeed be made with the stick.
- b) Qualitative pilot comments indicate that minimization of "glideslope lag," i.e., the minimization of "leading the correction" with the throttle is highly desirable.

Guidance information has a strong effect on the pilot's ability to perform the CV approach task. Results indicate that the HUD symbology is significant to the pilot's assessment of the task. Pilots would often attempt to measure their performance by the degree that the velocity vector (flightpath indicator) moved outside of the E-bracket (airspeed indicator).

The insertion of a step change in altitude at various ranges from the ship is a useful simulation tool to measure the ability of a configuration to make a rapid GS correction.

The overall approach task must be considered in the experiment. The GS tracking task cannot easily be isolated from the AOA (speed) management task. Both tasks are highly coupled for many aircraft configurations. Not unexpectedly, those configurations for which tasks were decoupled (such as high inclination of the effective thrust angle) were rated more highly.

FUTURE WORK

Upon completion of data analysis, a set of candidate criteria that effectively bound short-term flightpath response will be generated. These candidate criteria are likely to be a combination of frequency and space domain response metrics and a minimum level of flightpath control power where there is a significant vertical thrust inclination. Part of the justification of any new criteria should be their influence relative to existing accepted criteria and fleet experience.

THIS PAGE INTENTIONALLY LEFT BLANK

APPENDIX D
FIELD OF VIEW INVESTIGATIVE EFFORT

List of Figures

<u>Figure No.</u>	<u>Title</u>	<u>Page No.</u>
D-1	Mirror Template, Pilot’s View.....	183
D-2	FOV Rating Scale used in Phase 2	188

List of Tables

<u>Table No.</u>	<u>Title</u>	<u>Page No.</u>
D-1	Pilot Experience	183
D-2	FOV Phase 1 Test Points, Pilot A.....	184
D-3	FOV Phase 1 Test Points, Pilot B.....	185
D-4	FOV Phase 1 Test Points, Pilot C	185
D-5	FOV Phase 1 Test Points, Pilot D.....	186
D-6	FOV Phase 2 Test Point	186
D-7	FOV Legend of Data Tables	187
D-8	Ratings Assigned in Phase 2 Tests.....	190
D-9	Results Sorted by Average Ranking	191
D-10	Results Sorted by Worst Ranking Assigned	192

INTRODUCTION

BACKGROUND

FOV simulator experiments were conducted as part of the NAVAIRSYSCOM assessment of current CAC. Two days of testing were performed, on 11 January 2001 (Phase 1) and on 1 May 2001 (Phase 2).

PURPOSE

The purpose of the tests was to evaluate the effects of limited FOV on approach and landing flight phases.

DESCRIPTION OF TEST EQUIPMENT

The Virginia Tech flight simulator originally was the 2F122A A-6E Operational Flight Trainer (OFT). The 2F122A was declared "in excess" by the USN in 1995 and was transferred to Virginia Tech. Virginia Tech converted the 2F122A into a modern research tool that was compatible with the MFS XCASTLE flight simulation software. Acceleration cues are provided by a 3-DOF (roll, pitch, and yaw) cantilevered motion system. The cues have been optimized for normal PA flight. The visual system is a calligraphic display that presents night or dusk scenes. For these tests, when clear of clouds, the pilot was presented with a clear, bright horizon.

The aerodynamic model used for the FOV tests was the F/A-18A in configuration PA. The cockpit layout was that of an A-6E. There was no HUD, but the head-down VDI displayed all information required for the approach. The stick control loader was programmed to have the feel of an F/A-18E, and the rudder pedal feel was a simple spring. The AOA indexers were correct for the F/A-18A approach. The AOA analog indicator read in actual degrees so that the onspeed indication was not at the 3-o'clock position, but at 8.1 deg. The APC logic and gains were nominally correct for the F/A-18A.

The ship model was USS NIMITZ. The FLOLS was set for a 3.5 deg GS.

SCOPE OF TESTS

The scope of tests was limited to simulated Case III straight-in instrument approaches to visual landing conditions.

METHOD OF TESTS

All pilots were engineering test pilots. Four were currently or recently active in flight test, while pilot D was 22 years removed from flight test (see table D-1).

Table D-1: Pilot Experience

Pilot	A	B	C	D	E
Total flight time	1500	1400	2600	3500	1500
Primary fleet experience	F/A-18	F/A-18	F-14	F-8/F-4	F/A-18
Traps	325	377	349	420	350
Remarks	LSO	LSO			

FIELD OF VIEW RESTRICTIONS

FOV was varied using cardboard templates placed in the optics of the visual system. The shape of the templates was generally circular. Two locations were used for the templates. Templates placed on the cathode ray tube (CRT) display appeared to the pilot to be several hundred feet ahead of the aircraft, while templates placed on the mirror appeared at their actual distance. With the mirror template alone the pilot was able to change the FOV by head motion. FOV was fixed with the CRT template but the presentation did not appear realistic. Between Phases 1 and 2, it was determined that the CRT template was not distracting if used in combination with the mirror template. In figure D-1, a mirror template is seen at the bottom of the photograph.



Figure D-1: Mirror Template, Pilot's View

For the aircraft simulated, the FOV that just satisfies the criterion is 13 deg. In the results below, FOV is presented as the actual angle, so that a 12 deg FOV is 1 deg more restrictive than the criterion, 11 deg FOV is 2 deg more restrictive, etc.

DESIGN EYE POSITION

In Phase 1 (mirror template only), pilot adjusted his seat height so that a visual target in a predetermined position appeared exactly on the limb of the template. Pilots were instructed to

maintain the same head position during task execution. In Phase 2 (mirror and CRT templates), the pilot adjusted his seat height to align the edges of the two templates.

TASK

Pilots performed Case III approaches under IMC to VMC under a solid overcast. The approaches were straight-in and began at 6 nm and 1,200 ft MSL. The reference AOA for the APC was varied to present different initial conditions for the task. Similarly, the ILS on-and-on conditions were varied to present different initial GS and lineup errors. The pilot corrected to the ILS indicated centerline and flew level until intercepting the ILS-indicated GS. APC was used for all task setups, and maintained the aircraft fast, slow, or onspeed. The pilot broke out of the cloud cover at a nominal range of 5,500 ft from touchdown at an altitude of 250 ft (low), 400 ft (on GS), or 525 ft (high). Lineup was either on centerline or 3.5 deg left or right. Upon acquiring visual contact with the ship the task commenced. The pilot attempted to correct, as required, GS, lineup, and airspeed to position the aircraft for a successful landing.

TEST POINTS

Tables D-2 through D-5 show the test points flown in Phase 1. In Phase 2, all pilots flew the same points, shown in table D-6. Table D-7 gives the interpretations of the conditions listed in the test points.

Table D-2: FOV Phase 1 Test Points, Pilot A

Run No.	FOV	Speed	GS	Lineup	APC
1	13	On	On	On	Off
2	13	On	On	On	Off
3	13	Fast	High	On	Off
4	13	Slow	On	Left	Off
5	13	On	On	On	Off
6	13	Fast	On	Left	Off
7	13	On	On	On	On
8	13	Fast	High	On	Off
9	11	On	On	On	Off
10	11	On	On	On	Off
11	11	Fast	High	Left	Off
12	11	Slow	On	On	Off
13	11	Slow	High	Left	Off
14	11	Slow	Low	Left	Off
15	11	On	On	On	On
16	9	On	On	On	Off
17	9	Slow	Low	Left	Off

Table D-3: FOV Phase 1 Test Points, Pilot B

Run No.	FOV	Speed	GS	Lineup	APC
1	13	On	On	On	Off
2	13	Fast	Low	On	Off
3	13	Slow	Low	On	Off
4	13	Slow	Low	On	Off
5	13	Slow	Low	Left	Off
6	11	On	On	On	Off
7	11	Fast	Low	On	Off
8	11	Slow	On	On	Off
9	11	Slow	On	Left	Off
10	11	Slow	Low	Left	Off
11	11	Fast	On	Left	Off
12	9	On	On	On	Off
13	9	Slow	Low	Left	Off
14	9	On	On	On	On
15	7	On	On	On	Off
16	11	Slow	On	Left	Off
17	11	Slow	Low	Left	Off

Table D-4: FOV Phase 1 Test Points, Pilot C

Run No.	FOV	Speed	GS	Lineup	APC
1	13	On	On	On	Off
2	13	Slow	On	On	Off
3	13	Slow	Low	Left	Off
5	13	On	On	On	On
6	11	On	On	On	Off
7	11	Fast	On	Right	Off
8	11	Slow	On	On	Off
9	11	Slow	Low	Right	Off
10	11	Slow	Low	Left	Off
11	9	On	On	On	Off
12	9	Slow	Low	Left	Off

Table D-5: FOV Phase 1 Test Points, Pilot D

Run No.	FOV	Speed	GS	Lineup	APC
1	13	On	On	On	Off
2	13	Slow	Low	Left	Off
3	13	Fast	On	Right	Off
4	13	On	On	On	On
5	11	On	On	On	Off
6	11	Slow	On	Right	Off
7	11	Slow	High	Left	Off
8	11	Fast	Low	On	Off
9	11	Slow	Low	Right	Off
10	11	Slow	On	On	Off
11	11	Fast	High	On	Off
12	11	Slow	Low	Left	Off
13	11	On	On	On	On
14	11	On	On	On	Off
15	11	Slow	Low	Right	Off
16	11	Slow	High	Left	Off

Table D-6: FOV Phase 2 Test Points

Run No.	FOV	Speed	GS	Lineup	APC	WOD
1	13	On	On	On	On	Nom
2	13	On	On	On	Off	Nom
3	13	Slow	Low	Left	Off	Nom
4	13	Slow	Low	Right	On	Nom
5	12	On	On	On	On	Nom
6	12	Slow	High	Left	Off	Low
7	12	Fast	Low	On	On	Nom
8	12	Slow	Low	Right	Off	High
9	12	Fast	Low	Left	Off	Nom
10	11.5	On	On	On	On	Nom
11	11.5	Fast	High	On	Off	Low
12	11.5	Slow	Low	On	Off	Nom
13	11.5	Slow	Low	Right	On	Nom
14	11.5	Fast	High	Left	Off	High
15	11	On	On	On	On	Nom
16	11	Fast	Low	Right	Off	High
17	11	Slow	Low	Left	On	Nom
18	11	Fast	High	On	Off	Low
19	11	Slow	Low	Right	Off	Nom

Table D-7: FOV Legend of Data Tables

Speed: (alpha) (deg)	Slow	10.5
	On	8.1
	Fast	5.5
GS: (deg)	Low	1.9 (-1.6)
	On	3.5
	High	4.8 (+1.3)
Centerline: (deg)	Left	-3.5
	On	0
	Right	3.5
WOD: (kt)	Low	15
	Nominal	20
	High	25

PHASE 1 AND 2 DIFFERENCES

The primary differences in method between Phases 1 and 2 were as follows:

- a) The Phase 1 tests used the mirror template only, while the Phase 2 tests used both.
- b) The Phase 1 tests attempted to use a Cooper-Harper rating scale, reference 113, while Phase 2 tests used a FOV rating scale designed for these tests.
- c) In Phase 1 setups in which the aircraft was off-speed, pilots were directed to disengage the APC and continue the approach manually. A limited number of Phase 2 runs were conducted by resetting the APC datum to the correct approach AOA at the beginning of the task.
- d) Phase 1 WOD was 20 kt for all runs, while Phase 2 included some runs at 15 and 25 kt.
- e) FOV restrictions in Phase 1 ranged from nominal (just satisfies the current criterion) to 6 deg more restrictive in 2 deg increments. In Phase 2, attention was focused on 1, 1.5, and 2 deg less more restrictive FOV's than current criterion.
- f) Pilots A, B, C, and D participated in Phase 1; and pilots A, C, and E in Phase 2.
- g) FOV Rating Scale. The Cooper-Harper rating scale proved inadequate for the tests performed in Phase 1. The rating scale shown in figure D-2 was used in Phase 2.

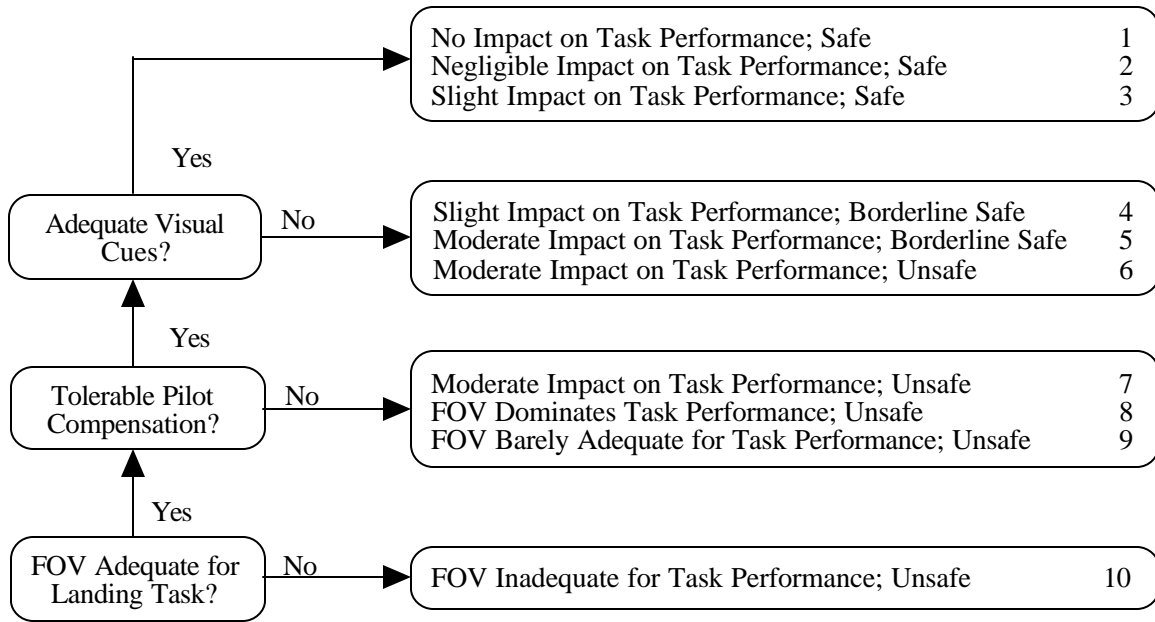

Figure D-2: FOV Rating Scale used in Phase 2

RESULTS AND DISCUSSION

PHASE 1 RESULTS

There was near-unanimous agreement that the FOV that just satisfies criterion (13 deg template) was adequate. Pilot A commented that the FOV was “good, very safe, Level 1” and noted that he never lost sight of the Landing Area (LA). Pilot B’s comments from a low, slow setup were that he was tempted to peek over the nose, otherwise FOV was not an issue. Pilot C, also from a low, slow setup, was conscious of the template, but FOV was not obstructed. Pilot D lost sight of the LA from a low, slow, lined-up left setup, but did not feel the technique employed was representative.

Approaches flown with a template 2 deg more restrictive than criterion (11 deg template) were generally deemed marginal. Pilot A, from low, slow positions, found the template right on the edge of the LA and, in one case, lost sight of the LA. The lost-sight case was not in close, and was considered safe. Pilot A felt that this FOV would be the limit. Pilot B observed the LA on the edge of the template when starting from ideal (On-On-On) setups. He noted that he was modifying his piloting technique to avoid losing sight of the LA. From a Low-Slow-Left setup, the pilot found he guessed at the appropriate correction, and felt the approach was unsafe. Pilot C, in the worst cases (Low-Slow setups), overcorrected early and was presented with High-Fast conditions, which were not a problem. Pilot D lost sight of the ship from Low setups that were Fast-On and Slow-Right, and declared the FOV unsatisfactory.

Approaches flown with a template 4 deg more restrictive than criterion (9 deg template) were considered unsatisfactory. Pilot A felt that, with an ideal start, he would have been able to safely land, but any combination of Low-Slow would have made the approach impossible. Pilots B and C concurred, and pilot B noted that from a Low-Slow-Left the LA was completely obscured. Pilot C,

from a Low-Slow-Left setup, had the ship in sight only 15% of the time of the approach. Pilot D did not fly with this template.

Only pilot B flew with a template 6 deg more restrictive than criterion (7 deg template), and deemed it unsatisfactory as the pilot never saw the ship.

DISCUSSION OF PHASE 1 RESULTS

General

Where FOV became limiting, all four pilots found themselves modifying their piloting techniques to some extent. It was common to observe stair stepping corrections for low conditions, in which a nose-up correction would be applied and then removed, repeated as necessary to reacquire GS. The loss of view of the LA during the nose-up correction placed the pilot in an open-loop control mode for a brief period of time, which was made as short as possible by using repeated small steps.

Peeking

With templates only on the mirror of the optics, it was possible for a pilot to improve the FOV by craning the neck. It is a natural tendency of pilots to move the head to improve FOV in actual approaches, and may be an unconscious action. This observation drove the decision to modify the templates in Phase 2.

Heads-Up Display

Pilots A, B, and C felt that a HUD would have made the task easier and could influence the results. Pilot D had no HUD experience.

Approach Power Compensation

Because the pilots disengaged the APC from off-speed starts, all the slow starts were flown using a back-side technique. It was felt, but not tested, that use of a front-side technique require larger nose-up corrections from below glidepath and hence be more critical cases. This observation drove the decision to reset the APC datum at task inception for some of the Phase 2 tests.

Critical Conditions

Throughout Phase 1, it was felt by all participants that the critical setups were those that commenced below GS (low), exacerbated by the condition of being slow. It was generally felt that right lineups required more FOV than left, owing to the FLOLS position on the left side of the LA.

Early in Phase 1 testing, it was found that the motion cues were distracting. The fidelity of the motion system became suspect. The motion system was not used for the results presented.

PHASE 2 RESULTS

Ratings

The ratings assigned by the three pilots are shown in table D-8.

Table D-8: Ratings Assigned in Phase 2 Tests

Run No.	FOV	Speed	GS	Lineup	APC	WOD	A	C	E
1	13	On	On	On	On	Nom	1	1	1
2	13	On	On	On	Off	Nom	1	1	1
3	13	Slow	Low	Left	Off	Nom	6	4	7
4	13	Slow	Low	Right	On	Nom	9	5	7
5	12	On	On	On	On	Nom	2	1	2
6	12	Slow	High	Left	Off	Low	3	2	1
7	12	Fast	Low	On	On	Nom	3	2	5
8	12	Slow	Low	Right	Off	High	2	10	7
9	12	Fast	Low	Left	Off	Nom	5	4	5
10	11.5	On	On	On	On	Nom	3	3	2
11	11.5	Fast	High	On	Off	Low	4	3	3
12	11.5	Slow	Low	On	Off	Nom	10	5	9
13	11.5	Slow	Low	Right	On	Nom	8	8	8
14	11.5	Fast	High	Left	Off	High	2	1	2
15	11	On	On	On	On	Nom	2	2	3
16	11	Fast	Low	Right	Off	High	10	2	10
17	11	Slow	Low	Left	On	Nom	5	NA	6
18	11	Fast	High	On	Off	Low	3	1	5
19	11	Slow	Low	Right	Off	Nom	10	8	7

As in Phase 1, there was near-unanimous agreement that the FOV that just satisfies criterion (13 deg template) was adequate. This conclusion is based on pilot comments. The ratings assigned did not support this conclusion. Run Nos. 3 and 4 were both performed with the 13 deg template, yet both received ratings that indicated the approach was unsafe. Pilots A and E declared both setups unsafe, while pilot C felt they were borderline safe. Run Nos. 3 and 4 were both from Low-Slow setups. The right lineup, APC on, received generally worse ratings than the left lineup, APC off.

The case of FOV 1 deg worse than criterion (12 deg template) further highlighted the role of the setup on the pilots' opinions. Here an On-On-On setup was easy to fly and considered safe. A slow and high setup was rated safe by all three pilots, while a low and fast setup was deemed marginally safe by one pilot, and safe by the other two. The Low-Slow setup was rated safe by one pilot and unsafe by the other two.

The results for the case of FOV 1.5 deg more restrictive than the criterion (11.5 deg template) are similar to those for the 12 deg template above. An On-On-On setup is still deemed safe, albeit with lower ratings. Both low setups were felt to be unsafe by the pilots, while Fast-High setups were safe.

Pilot opinion of approaches flown with a template 2 deg more restrictive than criterion (11 deg template) continued the trend seen with less restrictive FOV's. On-On-On approaches were felt to be safe, and Low setups, with one exception, were found unsafe.

Sorted Rankings

Table D-9 shows the Phase 2 results sorted by average ranking. Table D-10 shows the results sorted according to the worst ranking assigned by any pilot. There is no evidence of an influence due to FOV or use of APC. The dominant effect appears to be GS, with low setups considered more unsafe. Effects are also seen with respect to speed and lineup, with Slow-Right setups generally more unsafe.

Table D-9: Results Sorted by Average Ranking

Run No.	FOV	Speed	GS	Lineup	APC	WOD	A	C	E
1	13	On	On	On	On	Nom	1	1	1
2	13	On	On	On	Off	Nom	1	1	1
5	12	On	On	On	On	Nom	2	1	2
14	11.5	Fast	High	Left	Off	High	2	1	2
6	12	Slow	High	Left	Off	Low	3	2	1
15	11	On	On	On	On	Nom	2	2	3
10	11.5	On	On	On	On	Nom	3	3	2
18	11	Fast	High	On	Off	Low	3	1	5
7	12	Fast	Low	On	On	Nom	3	2	5
11	11.5	Fast	High	On	Off	Low	4	3	3
9	12	Fast	Low	Left	Off	Nom	5	4	5
17	11	Slow	Low	Left	On	Nom	5	NA	6
3	13	Slow	Low	Left	Off	Nom	6	4	7
8	12	Slow	Low	right	Off	High	2	10	7
4	13	Slow	Low	right	On	Nom	9	5	7
16	11	Fast	Low	right	Off	High	10	2	10
12	11.5	Slow	Low	On	Off	Nom	10	5	9
13	11.5	Slow	Low	right	On	Nom	8	8	8
19	11	Slow	Low	right	Off	Nom	10	8	7

Table D-10: Results Sorted by Worst Ranking Assigned

Run No.	FOV	Speed	GS	Lineup	APC	WOD	A	C	E
1	13	On	On	On	On	Nom	1	1	1
2	13	On	On	On	Off	Nom	1	1	1
5	12	On	On	On	On	Nom	2	1	2
14	11.5	Fast	High	Left	Off	High	2	1	2
6	12	Slow	High	Left	Off	Low	3	2	1
15	11	On	On	On	On	Nom	2	2	3
10	11.5	On	On	On	On	Nom	3	3	2
11	11.5	Fast	High	On	Off	Low	4	3	3
18	11	Fast	High	On	Off	Low	3	1	5
7	12	Fast	Low	On	On	Nom	3	2	5
9	12	Fast	Low	Left	Off	Nom	5	4	5
17	11	Slow	Low	Left	On	Nom	5	NA	6
3	13	Slow	Low	Left	Off	Nom	6	4	7
13	11.5	Slow	Low	Right	On	Nom	8	8	8
4	13	Slow	Low	Right	On	Nom	9	5	7
8	12	Slow	Low	Right	Off	High	2	10	7
16	11	Fast	Low	Right	Off	High	10	2	10
12	11.5	Slow	Low	On	Off	Nom	10	5	9
19	11	Slow	Low	Right	Off	Nom	10	8	7

Discussion of Phase 2 Results

Pilots generally liked the experimental setup and felt they were in fact assessing FOV. Initial conditions were felt to be representative of fleet extremes, but not necessarily representative of fleet experience.

The FOV rating scale was felt to be more useful than the CHR scale. Some pilots objected to the safe or unsafe descriptors. Additionally, there was some concern with the meaning of tolerable compensation, since open-loop control requires little or no compensation. Pilots felt that the final ratings (1-10) were well defined by the rating descriptions.

Pilots listed three factors that led to unsafe ratings: lost sight of LA for more than 2 sec, requirement to use open-loop control, and the requirement to modify piloting techniques. All three of these factors are related to obscuration of the LA due to limited FOV. Losing sight of the drop lights was considered a secondary objection.

CONCLUSIONS

Within the scope of the tests performed:

- a) The pilots' ratings contradicted their overall impression of the adequacy of the nominal FOV. The most reasonable explanation for this contradiction is that the low conditions used in these tests were too unrepresentative of any conditions the pilots had previously experienced. It is concluded that the unsafe ratings given to the low setups were not attributable to FOV restrictions.

- b) In Phases 1 and 2, it was the pilots' judgment that the criterion FOV was adequate. In light of 3.1, it is concluded that the existing criterion provides adequate FOV for the approach and landing task.
- c) No conclusions are drawn regarding the adequacy or inadequacy of more restrictive FOV than that provided by current criterion.

RECOMMENDATIONS

Conduct further testing using a HUD.

Undertake a study to determine the range of off-glide slope, off-centerline, and off-speed conditions that should be used to determine design-drivers, and repeat the tests using these variations.

THIS PAGE INTENTIONALLY LEFT BLANK

APPENDIX E
CHRONOLOGY OF CARRIER-BASED AIRCRAFT

Carrier Based Aircraft of U.S. Navy										
Aircraft	Name	Manufacturer	Engine	Sweep (Deg.) 0.25c/LE	IOC	End Service	Wing Area (Sq. Ft.)	AR	Max Trap Wt (Lbs.)	Vs, Vpa, LS (KEAS)
SBD-1	Dauntless	Douglas	R1820-32		Late 41	1945 (SBD-6)	325	5.3	7,000	Vs = 65
F4F-3/4	Wildcat	Grumman	R1830-76/86		Late 40/41	1945 (FM2)	260	5.55	6,000	Vs = 62
TBF-1	Avenger	Grumman	R2600-8		Mid 42	1954 (TBM-3E)	490	6	11,000	Vs = 61
F4U-1	Corsair	Vought	R2600-8		Mid 44	1955 (F4U-5N)	314	5.4	10,000	Vs=66, LS=80
USS Essex (CVS-9) commissioned 31 Dec 1942 (40,600 tons, length 890 ft., max beam 196 ft.) Introduced Mk4 Mod 5 Arresting Gear(55 kts@19,800 lbs)										
F6F-3	Hellcat	Grumman	R2600-16		Early 43	1953 (F6F-5N)	334	5.5	10,000	Vs = 62, LS=75-85
F8F-1	Bearcat	Grumman	R2800-34W		Mid 45	1953 (F8F-2)	244	5.26		
AD-1(A-1A)	Skyraider (Spad)	Douglas	R3350-26WA		Late 46	see A-1H/G	400	6.25	17,500	Vs = 68
USS Antietam (CVS-36) commissioned 28 Jan 1945 (38,000 tons, length 888 ft., max beam 154 ft.)										
USS Midway (CVA-41) commissioned 10 Aug 1945 (64,000 tons, length 972 ft., max beam 238 ft.)										
FH-1	Phantom	McDonnell	(2) J30-WE-20		Mid 47	1950 (FH-1)	276	6.02		
FJ-1	Fury	North American	J35-A-2	straight	Early 48	1949 (FJ-1)	221	6.59		
First carrier qualified jet squadron (16 FH-1 Phantoms) aboard USS Saipan (CVL-48) 5 May 1948										
First Use of Ejection Seat in Navy F2H-1 at 597 KIAS - August 1948										
F2H-2 (F-2)	Banshee	McDonnell	(2)J34-WE-34	minus 3.3	Mid 49	1959 (F2H-4)	294	6.84	15,300	Vs=86@13.7K,LS=110
F9F-5	Panther	Grumman	J48-P-6A	straight	Late 50	1958 (F9F-5)	250	7.8	12,600	Vs=91@11.5K,LS=110
F9F-6/8(F-9F/J)	Cougar	Grumman	J48-P-8	35	Late 52 (-6)	1960 (F9F-8P)	300/337	4.0/3.5	14,000/17,613	Vs/VPA=93@14/117@13K
F3D-1(F-10A)	Skynight	Douglas	(2)J34-WE-34	3.5	Early 51	1970 (EF-10B)	400	6.23	20,000	Vs = 81@18K
First operations (Flat Pass, no mirror) aboard first angled deck carrier USS Antietam ((CVS-36) 12 Jan 1953 ---- 27 July 1953 Korean War Ended										
F7U-3M	Cutlass	Vought	(2)J46-WE-8	35	Mid 54	1957 (F7U-3M)	535	2.95	23,500	Vs/VPA=105@23/117@21K
MDC Rpt. 32 "The Minimum Landing Approach Speed of High Performance Aircraft" dtd Oct. 1953 -- Prior to this Criteria was 1.1 Vs										

NOTES: Data presented was taken from:

- (1) United States Naval Aviation 1910-1995 by the Naval Aviation History Office, reference 6 (<http://www.history.navy.mil>).
- (2) United States Navy Aircraft since 1911 by Gordon Swanborough and Peter M. Bowers, Putnam Aeronautical Books, London, 3rd edition published 1990 (reference 5).
- (3) Internal NAVAIRSYSCOM files. When conflicting data between references was identified, the internal NAVAIRSYSCOM files took precedence.

Carrier Based Aircraft of U.S. Navy										
Aircraft	Name	Manufacturer	Engine	Sweep (Deg.) 0.25c/LE	IOC	End Service	Wing Area (Sq. Ft.)	AR	Max Trap Wt (Lbs.)	Vs, Vpa, LS (KEAS)
S2F-1(S-2A)	Tracker	Grumman	(2)R1820-82	1.6	Early 54	1984 (S-2E)	499	10.56	20,000	
FJ-3(F-1C)	Fury	North American	J65-W-4	35.7	Late 54	1962 (F-1E)	302	4.56	14,916-17,000	Vs/VPA=103@15/115@13K
TF-1(C-1A)	Trader	Grumman	(2)R1820-82		1955	1988 (C-1A)	499	10.56		
Evaluation of Mirror Landing System with FJ-3 Fury on USS Bennington (CVS-20) 22 Aug 1955										
USS Forrestal (CVA-59) commissioned 1 Oct 1955 (78,000 tons, length 1040 ft., max beam 252 ft.) Introduced Mk7 Mod1 Arresting Gear (110 kts@25,000 lbs; with dampers 130 kts@20,000 lbs)										
USS Saratoga (CVA-60) commissioned 14 Apr 1956 Introduced Mk7 Mod 2 Arresting Gear (135 kts@26,000 lbs)										
F3H-2(F-3B)	Demon	McDonnell	J71-A-2	43.2	Mid 56	1964 (F-3B)	519	2.41	26,700	Vs = 94@25.5K
A3D-1(A-3A)	Skywarrior	Douglas	(2)J57-P-6	35.9	Mid 56	1991 (KA-3B)	779	6.47	49,000	Vs = 98@42K
F4D-1(F-6A)	Skyray	Douglas	J57-P-2	46.5	Mid 56	1964 (F-6A)	557	2.02	21,000	Vs/VPA=100@19/123@16K
AD-6/7(A-1H/J)	Skyraider (Spad)	Douglas	R3350-26	3	Late 56	1971 (EA-1F)	400	6.25	17,500	Vs = 68
F11F-1(F-11A)	Tiger	Grumman	J65-W-18	35	Early 57	1961 (F11F-1)	250	4	15,907	Vs = 103@15K
A4D-2(A-4B)	Skyhawk	Douglas	J65-W-16A	33.2/35.69	Mid 57	see A-4M	260	2.91	11,560	Vs = 87@10.5K
F8U-1(F-8A)	Crusader	Vought	J57-P-4	42	Mid 57	see F-8J	375	3.4	20,000	
First Automatic Carrier Landing System (ACLS) Landing with F3D Skynight on USS Antietam (CVS-36) 12 Aug 1957										
WF-2(E-1B)	Tracer(Willy Fudd)	Grumman	(2)R1820-82		Late 60	1978 (E-1B)	499	10.56		
BuAer Aero and Hydro Tech Memo 1-59 Recognizes that 130% Stall Speed is not Adequate for High Performance Jet Aircraft Approach Speed Prediction										
T2J-1(T-2A)	Buckeye	North American	J34-WE-36	2.3	Mid 59	1973 (T-2A)	255	5.71	10,282	
Modernization (angled deck and mirror) of World War II Designed Carriers completed with recommissioning of USS Coral Sea (CVA-43) 5 Jan 1960										
A3J-1(A-5A)	Vigilante	North American	(2)J79-GE-2/4/8	37.5	Mid 61	RA-5Cs in 64	700	4	38,500	Vs = 106@36K
F4H-1 (F-4B)	Phantom II	McDonnell	(2)J79-GE-2/8	45/51.4	Mid 61	see F-4J	530	2.82	34,000	VPA = 132
First Use of NATOPS (Standardized Procedures) - 1961										

NOTES: Data presented was taken from:

- (1) United States Naval Aviation 1910-1995 by the Naval Aviation History Office, reference 6 (<http://www.history.navy.mil>).
- (2) United States Navy Aircraft since 1911 by Gordon Swanborough and Peter M. Bowers, Putnam Aeronautical Books, London, 3rd edition published 1990 (reference 5).
- (3) Internal NAVAIRSYSCOM files. When conflicting data between references was identified, the internal NAVAIRSYSCOM files took precedence.

Carrier Based Aircraft of U.S. Navy										
Aircraft	Name	Manufacturer	Engine	Sweep (Deg.) 0.25c/LE	IOC	End Service	Wing Area (Sq. Ft.)	AR	Max Trap Wt (Lbs.)	Vs, Vpa, LS (KEAS)
USS Enterprise (CVAN 65) commissioned 25 Nov 1961 (89,600 tons, length 1102 ft., max beam 252 ft.)										
VAX RFP in 1962 had Rqmts Similar to Current Rqmts (Did not have Small Thrust Response or Define Vision), VAX became VAL (A-7) in 1963										
BuWeeps Problem Assignment RAD33-210 Requests NATC to Evaluate Approach Speed Criteria dtd 17 Apr 1963										
A2F-1(A-6A)	Intruder	Grumman	(2)J52-P-6/8	25/29.5	Late 63	A-6B/C in 70	528.9	5.31	32,605-33,637	
A3J-3(RA-5C)	Vigilante	North American	(2)J79-GE-10	37.5	Mid 64	1981 (RA-5C)	754	3.73	47,000	Vs = 103@44K
W2F-1(E-2A)	Hawkeye	Grumman	(2)T56-A-8/522	4.95	Early 64	E-2Bs in 69	700	9.27		
T-2B	Buckeye	North American	(2)J60-P-6	2.3	Late 65		255	5.71	12,000	
A2F-1H (EA-6A)	Intruder	Grumman	(2)J52-P-6/8	25/29.5	1971	1979	528.9	5.31	36,061	
NATC Rpt FT-27R-66 dtd 16 Mar 1966 Recommended minor Changes to Approach Speed Criteria										
TA-4F	Skyhawk	Douglas	J52-P-8A	33.2/35.69	Mid 66	Early 90s	260	2.91	14,500-15,000	Vs=108,VPA=131
F-4J	Phantom II	McDonnell	(2)J79-GE-10	45/51.4	Late 66	1989 (F-4S)	530	2.82	38,000	VPA=138
C-2A	Greyhound	Grumman	(2)T56-A-8/425	4.95	Late 66		700	9.27	44,000	Vs=78,VPA=105
A-7A	Corsair II	Vought	TF30-P-6	35	Mid 67	see A-7E	375	4	24,431	Vs=114,VPA=133
F-8J	Crusader	Vought	J57-P-20/420	42	Mid 68	1982 (RF-8G)	375	3.4	25,000	Vs=117,VPA=137
A-7B	Corsair II	Vought	TF30-P-8	35	Mid 68	see A-7E	375	4	26,200	Vs=118,VPA=137
USS John F. Kennedy (CVA-67) commissioned 7 Sep 1968 Introduced Mk 7 Mod 3 Arresting Gear (145 kts@40,000 lbs)										
T-2C	Buckeye	Rockwell	(2)J85-GE-4	2.3	Early 69		255	5.7	12,000	VPA=107
A-7E	Corsair II	Vought	TF41-A-2	35	Mid 69	1992 (A-7E)	375	4	26,200	Vs=118,VPA=137
A-4M	Skyhawk	Douglas	J52-P-408	33.2/35.69	Early 71	1994 (A-4M)	260	2.91	14,500	Vs=104,VPA=129
A-6E	Intruder	Grumman	(2)J52-P-8	25/29.5	Late 71		528.9	5.31	36,000	Vs=92,VPA=128
EA-6B	Prowler	Grumman	(2)J52-P-8/408	25/29.5	Mid 71		528.9	5.31	45,500	Vs=104,VPA=129
E-2C	Hawkeye	Grumman	(2)T56-A-425	4.95	Late 73		700	9.27	45,000	Vs=79,VPA=105
F-14A	Tomcat	Grumman	(2)TF30-412	15.9/20	Mid 73		565	7.28	51,830	Vs=110,VPA=134

NOTES: Data presented was taken from:

- (1) United States Naval Aviation 1910-1995 by the Naval Aviation History Office, reference 6 (<http://www.history.navy.mil>).
- (2) United States Navy Aircraft since 1911 by Gordon Swanborough and Peter M. Bowers, Putnam Aeronautical Books, London, 3rd edition published 1990 (reference 5).
- (3) Internal NAVAIRSYSCOM files. When conflicting data between references was identified, the internal NAVAIRSYSCOM files took precedence.

Carrier Based Aircraft of U.S. Navy										
Aircraft	Name	Manufacturer	Engine	Sweep (Deg.) 0.25c/LE	IOC	End Service	Wing Area (Sq. Ft.)	AR	Max Trap Wt (Lbs.)	Vs, Vpa, LS (KEAS)
S-3A	Viking	Lockheed	(2)TF34-GE-2	15	Mid 74		598	7.88	37,695-40,500	Vs=96,VPA=116
A-6E TRAM	Intruder	Grumman	(2)J52-P-8	25/29.5	Late 78		528.9	5.31	36,000-38,000	Vs=95,VPA=132
F-18A/B	Hornet	McDonnell Douglas	(2)F404-GE-400	20/26.7	Mid 83		400	3.5	30,700-33,000	Vs=112,VPA=139
C-2A(R)	Greyhound	Grumman	(2)T56-A-425	4.95	Mid 85		700	9.27	49,058	Vs=81,VPA=103
F-14A+	Tomcat	Grumman	(2)F110-GE-400	15.9/20	Early 88		565	7.28	54,000	Vs=112,VPA=138
E-2C	Hawkeye	Grumman	(2)T56A427	4.95	Early 88		700	9.27	42,180-46,500	Vs=81,VPA=106
F-14D	Tomcat	Grumman	(2)F110-GE-400	15.9/20	Mid 90		565	7.28	54,000	Vs=112,VPA=138
F/A-18C/D	Hornet	McDonnell Douglas	(2)F404-402	20/26.7	Early 91		400	3.5	34,000	Vs=114,VPA=141
T-45A	Goshawk	McDonnell Douglas	F405-RR-401	23.7/28.26	Mid 92		179.64	5.01	13,360	Vs=101, VPA=125
F-18E/F	Super Hornet	Boeing	(2)F414-GE-400	22.3/29.4	Early 2002		500	3.5	42900-44,000	Vs=114,VPA=140

NOTES: Data presented was taken from:

- (1) United States Naval Aviation 1910-1995 by the Naval Aviation History Office, reference 6 (<http://www.history.navy.mil>).
- (2) United States Navy Aircraft since 1911 by Gordon Swanborough and Peter M. Bowers, Putnam Aeronautical Books, London, 3rd edition published 1990 (reference 5).
- (3) Internal NAVAIRSYSCOM files. When conflicting data between references was identified, the internal NAVAIRSYSCOM files took precedence.

DISTRIBUTION:

- NAVAIRSYSCOM (AIR-5.0E), Bldg. 304, Room 120 (1)
22541 Millstone Road, Patuxent River, MD 20670-1606
- NAVAIRSYSCOM (AIR-4.3.2.4/Cook), Bldg. 2187, Room 1380 (10)
48110 Shaw Road, Patuxent River, MD 20670
- NAVAIRSYSCOM (AIR-4.3.2.2/Rudowsky), Bldg. 2187, Room 1343 (10)
48110 Shaw Road, Patuxent River, MD 20670
- NAVAIRWARCENACDIV (4.11), Bldg. 304, Room 102 (1)
22541 Millstone Road, Patuxent River, MD 20670-1606
- NAVAIRWARCENACDIV (7.2.5.1), Bldg. 405, Room 108 (1)
22133 Arnold Circle, Patuxent River, MD 20670-1551
- NAVTESTWINGLANT (55TW01A), Bldg. 304, Room 200 (1)
22541 Millstone Road, Patuxent River, MD 20670-1606
- DTIC (1)
8725 John J. Kingman Road, Suite 0944, Ft. Belvoir, VA 22060-6218

UNCLASSIFIED

UNCLASSIFIED